



TAPERED AND LENSED FIBERS

Features:

- Improved coupling to and from waveguides, laser diodes and photodiodes
- Singlemode, Multimode or Polarization Maintaining Fibers
- AR coated endfaces available
- Can be made based on either spot size or taper shape
- Metalized fiber versions available
- Hermetically sealable versions available
- Other custom configurations available

Applications:

- Active component pigtailing
- DWDM devices
- Waveguide packaging
- MEMS device connections
- Miniaturized fiber optic components
- Coupling to circular or elliptical beam outputs

Product Description:

Tapered and lensed fibers offer a convenient way to improve coupling between optical fibers and waveguide devices, laser diodes or photo diodes. By laser shaping the fiber end, the light can be transformed to improve mode matching and coupling efficiency with the waveguide device, laser diode chip or photodiode chip. The manufacturing process allows for improved coupling to either circular or oval input spots (this must be specified in advance).

OZ Optics tapered and lensed fibers are manufactured by laser shaping the endface to create the optimal light output/input for specific applications. This method provides the best coupling efficiencies and mode matching abilities in a taper. An alternative technique is to instead polish the end face of the fiber to a specific radius and taper angle, forming a lens. Oval spots can also be formed using the polishing technique, normally by shaping the fiber to form a chisel shape.

The characteristics of fiber tapers depend greatly upon the application. For laser diode and waveguide coupling applications, beam quality is paramount. The focused spot characteristics must

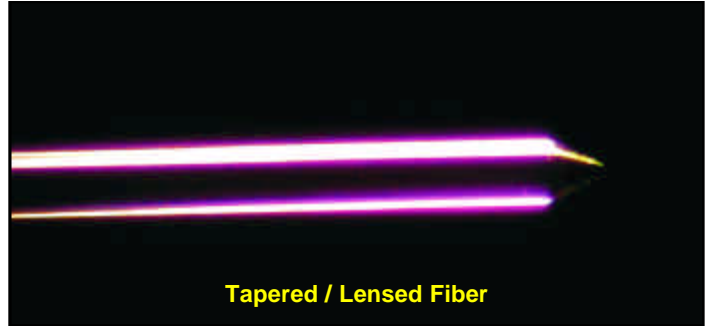

match the waveguide characteristics as closely as possible to ensure good coupling. In contrast, fiber to photodiode coupling does not require a high quality beam. One only has to ensure that the focused spot size is smaller than the photodetector. Thus tapered fibers for photodiodes are offered at lower cost.

Singlemode, Multimode or Panda Type Polarization Maintaining (PM) fibers can be tapered. For multimode fibers, only polished versions, with a polish radius and taper angle can be produced. While they can improve coupling efficiencies when used with laser diodes or VCSELs, they do not focus to an actual spot like singlemode and PM fiber versions do.

PM fibers offer a means to control the polarization of optical signals throughout the system, thus controlling Polarization Dependent Losses (PDL) and Polarization Mode Dispersion (PMD). This control is crucial in developing high speed 10 Gb/s, and next generation 40 Gb/s and faster systems. In general, OZ Optics uses PM fibers based on the PANDA fiber structure when building polarization maintaining components and patchcords. However OZ Optics can construct devices using other PM fiber structures. We do carry some alternative fiber types in stock, so please contact our sales department for availability. If necessary, we are willing to use customer supplied fibers to build devices.

Custom configurations can be designed if required. Tapered fibers can be incorporated into other OZ Optics assemblies including Hermetic Patchcords and V-Groove assemblies, thus aiding in the development of photonic devices that meet Telcordia requirements. Contact OZ Optics for more information.

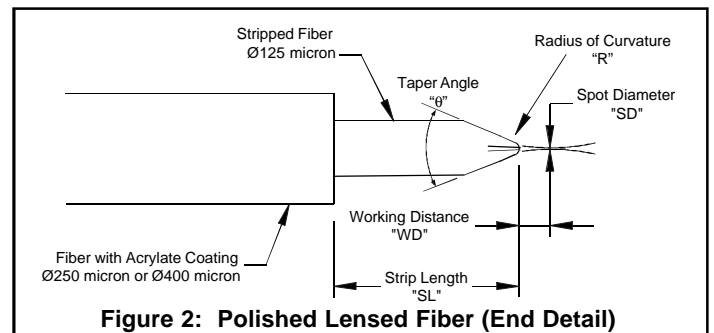
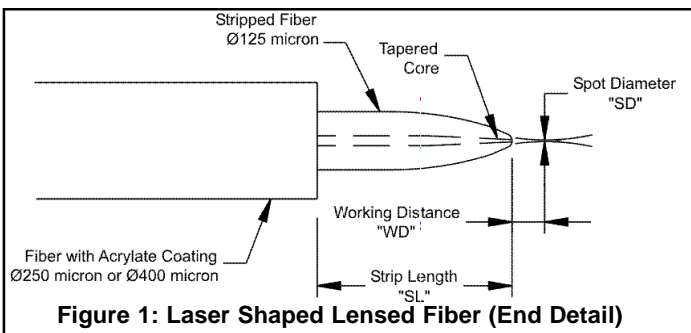

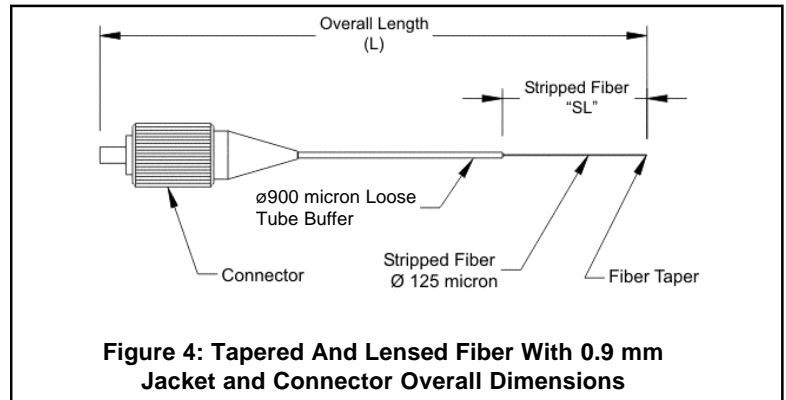
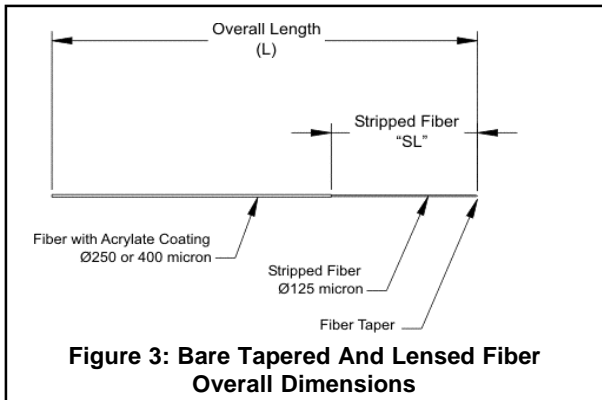

Ordering Information For Standard Parts:

Table 1: Singlemode Tapered / Lensed Fibers

Bar Code	Part Number	Description
12857	TSMJ-X-1550-9/125-0.25-7-5-26-2	2 meter long, 0.25 mm OD jacketed Corning SMF 28 fiber with tapered tip on one end, no connector on the other end; 7 mm stripped length, spot diameter of 5 ± 0.5 microns, working distance of 26 ± 3 microns
12858	TSMJ-X-1550-9/125-0.25-7-5-26-2-AR	2 meter long, 0.25 mm OD jacketed Corning SMF 28 fiber with tapered tip on one end, no connector on the other end; 7 mm stripped length, spot diameter of 5 ± 0.5 microns, working distance of 26 ± 3 microns, and AR coating on the tip
14919	TSMJ-X-1550-9/125-0.25-7-2.5-14-2	2 meter long, 0.25 mm OD jacketed Corning SMF 28 fiber with tapered tip on one end, no connector on the other end; 7 mm stripped length, spot diameter of 2.5 ± 0.3 micron, working distance of 14 ± 2 micron
20276	TSMJ-X-1550-9/125-0.25-7-2.5-14-2-AR	3 meter long, 0.25 mm OD jacketed Corning SMF 28 fiber with tapered tip on one end, no connector on the other end; 7 mm stripped length, spot diameter of 2.5 ± 0.3 microns, working distance of 14 ± 2 microns and AR coating on the tip
13498	TSMJ-X-1550-9/125-0.25-20-2.5-14-3	3 meter long, 0.25 mm OD jacketed Corning SMF 28 fiber with tapered tip on one end, no connector on the other end; 20 mm stripped length, spot diameter of 2.5 ± 0.3 micron, working distance of 14 ± 2 micron
13475	TSMJ-X-1550-9/125-0.25-20-2.5-14-3-AR	3 meter long, 0.25 mm OD jacketed Corning SMF 28 fiber with tapered tip on one end, no connector on the other end; 20 mm stripped length, spot diameter of 2.5 ± 0.3 microns, working distance of 14 ± 2 microns and AR coating on the tip

Table 2: Polarization Maintaining Tapered / Lensed Fibers

Bar Code	Part Number	Description
12663	TPMJ-X-1550-8/125-0.4-7-5-26-1	2 meter long, 0.40 mm OD jacketed 8/125 1550 nm polarization maintaining fiber with tapered tip on one end, no connector on the other end; 10 mm stripped length, spot diameter of 5 ± 0.5 microns, working distance of 26 ± 3 microns
11356	TPMJ-X-1550-8/125-0.4-10-2.5-14-1	1 meter long, 0.40 mm OD jacketed 8/125 1550 nm polarization maintaining fiber with tapered tip on one end, no connector on the other end; 10 mm stripped length, spot diameter of 2.5 ± 0.5 microns, working distance of 14 ± 2 microns
11372	TPMJ-X-1550-8/125-0.4-10-2.5-14-1-AR	1 meter long, 0.40 mm OD jacketed 8/125 1550 nm polarization maintaining fiber with tapered tip on one end, no connector on the other end; 10 mm stripped length, spot diameter of 2.5 ± 0.5 microns, working distance of 14 ± 2 microns, and AR coating on the tip

Standard Product Specifications for Tapered / Lensed Fibers:

Focused spot size ¹	2.0 to 6.5 microns, at 13.5% ($1/e^2$) levels
Spot size tolerance	Standard tolerance is ± 0.5 microns. Available with a tolerance of ± 0.25 microns
Working distance ¹	3 to 30 microns
Working distance tolerance	$\pm 10\%$ of specified working distance
Polarization Extinction Ratio	Standard Grade >20 dB, Medium Grade >25 dB, Premium Grade >30 dB
Fiber Types	Singlemode, Multimode, Polarization Maintaining (PM)
Concentricity of spot relative to taper	0.7 micron standard; 0.25 micron also available for premium grade
Minimum strip distance	2 mm
Strip Length Tolerance	± 1 mm
Return Losses	-20dB standard, -25dB with AR coating

¹ Working distance is dependent upon focused spot size. Contact OZ to determine working distance for a given spot size.

Ordering Examples For Standard Parts:

A customer needs to couple a 2 meter long piece of bare singlemode fiber to a detector flip chip on a silicon optical bench with a square active area of 5 microns. The optimal working distance is not critical for the assembly of this device but it needs to have 7 mm of the acrylate removed.

Bar Code	Part Number	Description
12857	TSMJ-X-1550-9/125-0.25-7-5-18-2	2 meter long, 0.25 mm OD jacketed Corning SMF 28 fiber with tapered tip on one end, no connector on the other end; 7 mm stripped length, spot diameter of 5 ± 0.5 microns, working distance of 18 ± 2 microns

Ordering Information For Custom Parts:

OZ Optics welcomes the opportunity to provide custom designed products to meet your application needs. As with most manufacturers, customized products do take additional effort so please expect some differences in the pricing compared to our standard parts list. In particular, we will need additional time to prepare a comprehensive quotation, and lead times will be longer than normal. In most cases non-recurring engineering (NRE) charges, lot charges, and a 25 piece minimum order will be necessary. These points will be carefully explained in your quotation, so your decision will be as well-informed as possible. We strongly recommend buying our standard products.

Questionnaire For Custom Parts:

1. What wavelengths are you using?
2. What fiber size and type do you need?
3. What size of coating or jacketing do you want on the fiber?
4. How long should the stripped fiber length be?
5. How long should the fiber be?
6. Do you need a connector on the end of the fiber? If yes, what type?
7. Should the tapered fiber end be anti-reflection coated? For what wavelengths?
8. Are you coupling light to or from a waveguide?
If Yes,
 - a. What are the dimensions of the guided mode in microns?
 - b. What is the numerical aperture of the waveguide?
 - c. What is the desired working distance in microns?
9. Are you coupling light to a photodiode?
If Yes,
 - a. What is the photodiode chip size in microns?
 - b. What is the photodiode chip shape?
 - c. What is the desired working distance in microns?
10. Are you coupling light from a laser diode?
If Yes,
 - a. What are the dimensions of the guided mode in microns?
 - b. What is the angular profile of the light from the diode?
 - c. What is the desired working distance in microns?
11. Are you using tapered fibers for a different application?
If Yes,
 - a. What is the desired focused spot size in microns?
 - b. What is the desired working distance in microns?
 - c. Do you have a diagram of your intended application?
12. Are there any other special requirements that you need?

Description

Part Number

Tapered Lensed Fiber:

TFMJ-X-W-a/b-JD-SL-SD-WD-L(-AR)(-PD)¹

E = Fiber Type

M = Multimode
S = Singlemode
P = Polarization Maintaining

X = Connector Code

3S = Super FC
3U = Ultra FC
3A = Angled FC
8 = ST
SC = Super SC
SCU = Ultra SC
SCA = Angled SC
MU = Super MU
LC = Super LC
LCA = Angled LC
X = No Connector

W = Wavelength, in nanometers

1300/1550 for Corning SMF-28 Singlemode fiber

a/b = Fiber core/cladding

9/125 for Corning SMF-28 Singlemode fiber
6/125 for 980nm PANDA type PM fiber
7/125 for 1300nm PANDA type PM fiber
8/125 for 1550nm PANDA type PM fiber

AR = AR Coating for tapered end
Add -AR if anti-reflective coating is required

L = Overall Length, in meters

WD = Working Distance, in microns
3-50 microns available

SD = Spot Diameter, in microns (1/e²)
2.0-7.5 microns available

SL = Strip Length, in millimeters

JD = Jacket Diameter

0.25 = 250 micron OD acrylate coating²
0.40 = 400 micron OD acrylate coating²
1 = 900um Hytrel loose tube buffered fiber

Notes:

- 1 Add -PD for low cost tapers for photodiode packaging
- 2 Singlemode fiber normally has a 250 micron coating. PM fiber has 400 or 250 micron coating.

Description

Part Number

Polished Lensed Fiber:

TFMJ-X-W-a/b-JD-SL-R-q-L-POL(-AR)(-PD)¹

E = Fiber Type

M = Multimode
S = Singlemode
P = Polarization Maintaining

X = Connector Code

3S = Super FC
3U = Ultra FC
3A = Angled FC
8 = ST
SC = Super SC
SCU = Ultra SC
SCA = Angled SC
MU = Super MU
LC = Super LC
LCA = Angled LC
X = No Connector

W = Wavelength, in nanometers

1300/1550 for Corning SMF-28 Singlemode fiber

a/b = Fiber core/cladding

9/125 for Corning SMF-28 Singlemode fiber
6/125 for 980nm PANDA type PM fiber
7/125 for 1300nm PANDA type PM fiber
8/125 for 1550nm PANDA type PM fiber

AR = AR Coating for tapered end
Add -AR if anti-reflective coating is required

L = Overall Length, in meters

q = Taper angle in degrees

R = Radius of tip, in microns

SL = Strip Length, in millimeters

JD = Jacket Diameter

0.25 = 250 micron OD acrylate coating²
0.40 = 400 micron OD acrylate coating²
1 = 900um Hytrel loose tube buffered fiber

Notes:

- 1 Add -PD for low cost tapers for photodiode packaging
- 2 Singlemode fiber normally has a 250 micron coating. PM fiber has 400 or 250 micron coating.

Ordering Example For Custom Parts:

A customer needs to couple a 1.5 meter long piece of unjacketed 1550 nm Panda Style PM fiber to a detector flip chip on a silicon optical bench with a square active area of 5 microns. The optimal working distance is not critical for the assembly of this device but it needs to have 15 mm of the acrylate removed. The customer also wants an FC/APC connector on the end.

Part Number	Description
TPMJ-3A-1550-8/125-0.4-15-5-18-1.5	1.5 meter long, 0.40 OD jacketed 8/125 1550 nm polarization maintaining fiber with tapered tip on one end, angle FC/PC connector on the other end; 15 mm stripped length, spot diameter of 5 ± 0.7 microns, working distance of 18 ± 2 microns.

Frequently Asked Questions (FAQs):

Q: What are the advantages and disadvantages of laser shaped versus polished tapered/lensed fibers?

A: Laser shaping allows more complex tapered endface geometries than simple polishing can produce. As a result they offer greater flexibility in making focusers with custom spot sizes. Focusers can be made with spot sizes as small as 2 microns with the drawing technique. For comparison, polished tapered fibers cannot produce spot sizes smaller than 3.5 microns without introducing significant aberrations. One can therefore make laser shaped lensed fibers with improved coupling efficiency compared to polished fibers in many applications. The laser shaping process is also fully automatable, allowing one to make drawn fibers in volume at lower costs than polished fibers.

On the other hand polished fibers feature better centration with respect to the cladding compared to laser shaped fibers. They are therefore better suited for applications such as V-groove arrays, where one wants precise spacing between adjacent tapers. Laser shaped tapers are better suited for single fiber applications.

Q: I saw tapered fibers specified by taper angle and radius of curvature. Why aren't your tapered fiber versions?

A: In order to simplify the specifications and ensure that the customers understand exactly what they will be receiving, we have specified the actual output that the tapered fiber will provide as opposed to the physical geometry which takes several complicated formulas to determine the actual output. The method used to manufacture the OZ Optics tapered fibers creates a structure difficult to physically measure but does provide the required output characteristics. To accommodate users familiar only with polished lensed fibers, we now offer them as an alternative.

Q: What does adding an AR coating improve, and by how much?

A: An AR coating is an antireflection coating which typically reduces the effects of light reflecting back into the fiber from the fiber endface (backreflection). In the case of the tapered fibers an AR coating has the potential of increasing the coupling ability by up to 10%. The power will be better transmitted through the end of the fiber instead of reflecting in the opposite direction. This will reduce the etalon effects, which will reduce laser feedback and improve the laser diode stability.

Q: Can I get multimode tapers?

A: Yes, although the tapered fiber behavior is mode dependent.

Q: I have seen advertised tapered multimode fibers. Are these the same?

A: No. Tapered multimode fibers take a long section of fiber and gradually taper the full length to convert it from a larger core diameter on one end to a smaller core diameter on the other end. These are typically used with connectors on both ends and are used for a completely different application.

Q: What are your standard spot sizes?

A: 2.5 micron and 5 micron are the standard spot sizes. However others can be manufactured.

Q: I have seen specifications for polished tapered fibers from other manufacturers. Is your product polished?

A: OZ Optics' standard product uses a laser shaping method to achieve the appropriate focused size and working distance. We now also have a polished fiber version, which is indicated with a -POL in the part number.

Q: Can the same fiber tapers be used for 1300 nm as well as 1550 nm?

A: The current designs are optimized for 1550 nm. Due to the difference in the mode field diameter for the different wavelengths, expect the spot sizes to be between 10% and 15% smaller, with slight changes in the working distance.

Q: What is the relationship between the focused spot size and working distance?

A: While this depends somewhat on the fiber type and wavelength, for 1550nm wavelengths and Corning SMF-28 fiber the relationship is as follows.

Spot Diameter (microns)	Working Distance (microns)
2.0	11.0
2.5	14.0
3.0	16.5
3.5	19.0
4.0	21.5
4.5	24.0
5.0	26.0
5.5	27.5
6.0	29.0
6.5	30.5

Application Notes:

How do tapered fibers work? Tapered fibers work by focusing the light to improve the mode matching between a waveguide and the fiber. Normally we try to get a taper that produces a Gaussian Beam, as shown in Figure 5. Ideally the tapered fibers should be made to precisely match the laser diode or waveguide characteristics. Be prepared to supply as much information as possible to help develop the ideal taper. Spot sizes for tapered fibers are normally specified in terms of the 1/e² points. This may differ from your own standard definition. To convert, use the following table.

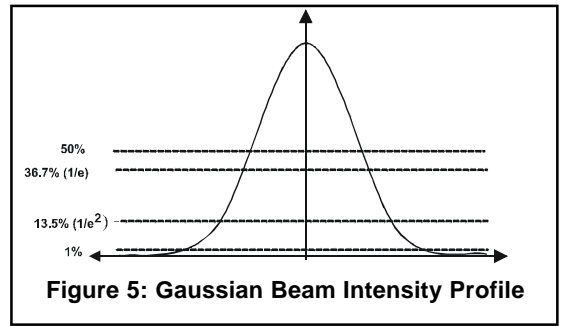

Convert From	Convert To (Multiply By)			
	50% (FWHM)	36.7% (1/e)	13.5% (1/e ²)	1%
50% (FWHM)	1	1.20	1.70	2.58
36.7% (1/e)	0.83	1	1.41	2.15
13.5% (1/e ²)	0.589	0.707	1	1.517
1%	0.388	0.466	0.659	1

Cabling Tapered Fibers: Standard tapered fibers have just a 250 micron or 400 micron acrylate coating on them, depending on the fiber manufacturer. It is often necessary to add a protective jacket or cable to the tapered fiber before it can be installed into a product.

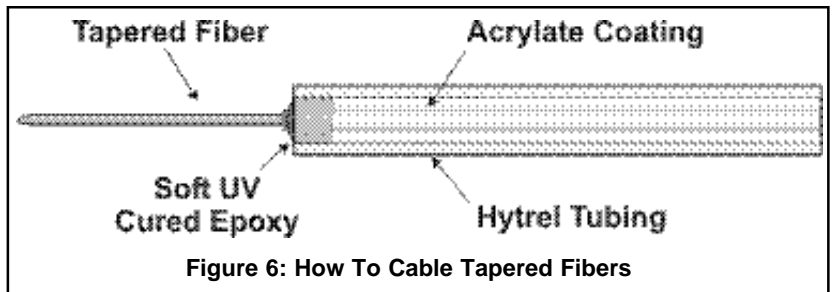

OZ Optics can cable the tapered fibers for you using 900 micron outer diameter loose hytrel tubing. This provides the extra protection needed. To ensure the tubing remains in place, a drop of soft UV cured epoxy is applied between the acrylate coating of the fiber and the tubing (See Figure 6). Thicker cabling can also be used, depending on the application.

Application Example: Using tapered fibers in a hermetically sealable patchcord

A common application for tapered fibers is in laser diode to fiber coupling. Because of the reliability requirements laser diodes must meet, hermetic packaging is almost mandatory. Fortunately tapered fibers lend themselves easily to hermetic sealing.

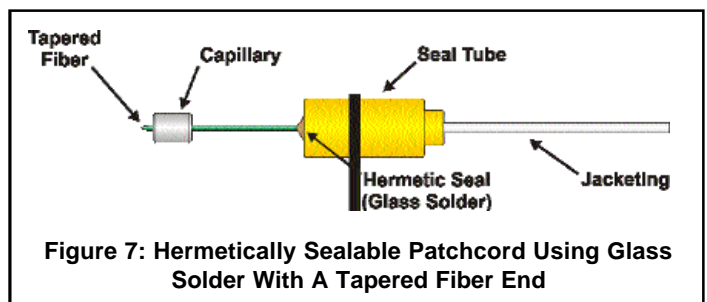

As shown in Figure 7, a tapered fiber can be easily installed into a tapered fiber assembly. The optional capillary provides a way to grip the tapered fiber end with micromanipulators, allowing it to be aligned to the laser diode to achieve optimum coupling efficiency. The hermetic seal tube can be soldered or welded to the external package, completing the seal. The fiber can be either metalized and soldered into the seal tube with a high temperature solder, or simply stripped and soldered into place using specialized glass solders. This provides the hermetic seal. The final package would appear similar to Figure 8.

Both capillaries and seal tubes are available in a variety of sizes and geometries. For additional information, please refer to the data sheets titled *Hermetically Sealable Patchcords With Glass Solder* and *Hermetically Sealable Patchcords With Metal Solder*.

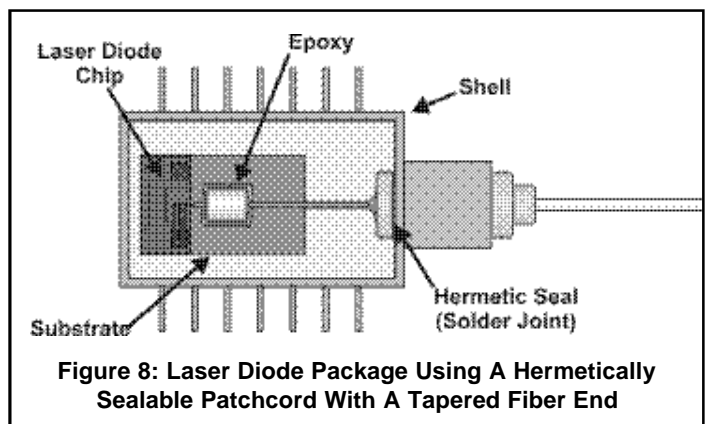

Application Example: Using tapered fibers for high speed photodiode packaging

In order to produce photodiodes capable of 40Gbit/s response speed or faster, the active area must be very small. Typical values are of the order of 20 microns or smaller. As a result, aligning fibers to photodiodes has become more critical. In addition, smaller package sizes are needed to fit more detectors within a DWDM substation. Finally, the drive to reduce costs has led to increased use of automation and scalable assembly processes.

First generation detector designs used cleaved fibers butted to the photodiode surface. However this method produced high backreflection levels, and also produced a structure that is not planar in design, making the device somewhat bulkier. Delicate wires had to be bonded onto the photodiode to make the product work. Second generation devices used ball or grin lenses to focus

the light onto the photodiode instead. This eliminated the return loss problem, but made the device bulkier and more costly.

The latest generation of products now use tapered fibers together with silicon optical bench techniques to couple light into a detector (See Figure 9). The fiber taper focuses the light to a spot a short distance from the fiber to get good coupling efficiency onto the diode while minimizing return losses. Use of a V-Groove in an optical bench substrate allows accurate passive alignment. Finally the mirrored surface at the end of the V-groove reflects the light onto the detector. This allows the photo fiber to be mounted face down, which also makes the structure planar. Wire bonding can be avoided, producing an overall design that is smaller and more reliable. Optionally the mirror end surface can be shaped to form a concave mirror, resulting in an even smaller spot and faster response times (see Figure 10).

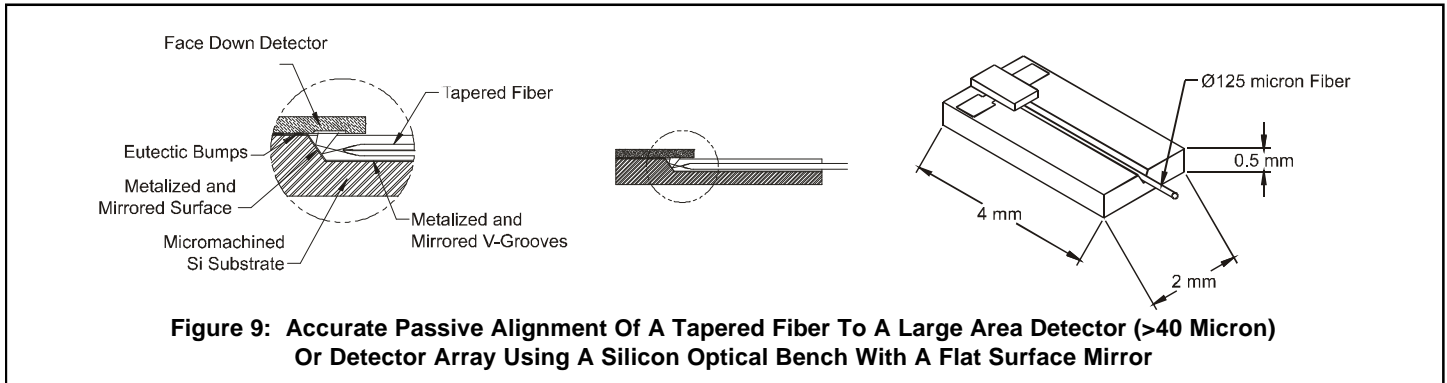

Figure 9: Accurate Passive Alignment Of A Tapered Fiber To A Large Area Detector (>40 Micron) Or Detector Array Using A Silicon Optical Bench With A Flat Surface Mirror

Product Description:

- Detector (PIN diode) / detector array is Flip-Chip bonded down-looking on the Silicon Optical Bench
- Fiducials on the silicon waferboard provide detector alignment
- Tapered fiber is passively, yet accurately aligned by V-Groove trenches
- Metalized V-Grooves provide mirrors
- Overall accuracy of alignment $\pm 0.5\mu\text{m}$
- SM fiber to detector coupling is >90%

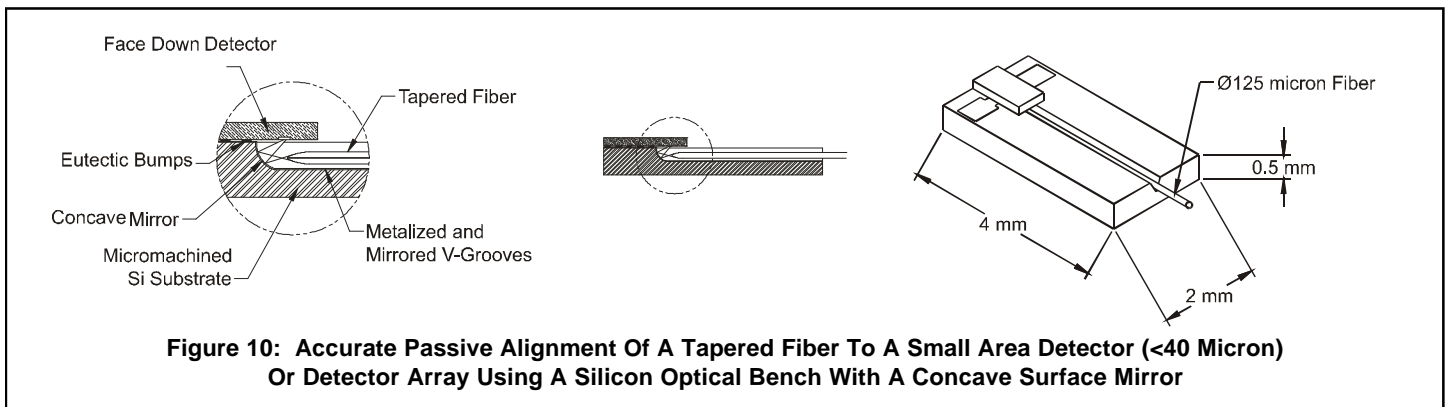

Figure 10: Accurate Passive Alignment Of A Tapered Fiber To A Small Area Detector (<40 Micron) Or Detector Array Using A Silicon Optical Bench With A Concave Surface Mirror

Product Description:

- Detector (PIN diode) / detector array is Flip-Chip bonded down-looking on the Silicon Optical Bench
- Fiducials on the silicon waferboard provide detector alignment
- Tapered fiber is passively, yet accurately aligned by V-Groove trenches
- Metalized V-Grooves provide mirrors
- Overall accuracy of alignment $\pm 0.5\mu\text{m}$
- SM fiber to detector coupling is >90%