



# OZ Optics

[www.ozoptics.com](http://www.ozoptics.com)

219 Westbrook Rd, Ottawa, ON, Canada, K0A 1L0 Toll Free: 1-800-361-5415 Tel: (613) 831-0981 Fax: (613) 836-5089 E-mail: [sales@ozoptics.com](mailto:sales@ozoptics.com)

## WAVELENGTH DIVISION MULTIPLEXERS

### Features:

- PM fiber versions
- Miniature inline Versions
- Visible wavelength (Red/Green/Blue) versions
- High power handling
- Low Insertion Losses
- Low return loss
- Wide wavelength range
- High power handling
- Coarse and dense WDM versions
- LOW COST!

### Applications:

- Drop/Add Filters for Telecommunications
- Fiber Lasers
- Erbium Doped Fiber Amplifiers
- Confocal Microscopy
- Laser Spectroscopy
- Imaging systems
- 980nm Pumping

### Product Description:

Wavelength division multiplexers (WDMs) are used to combine light of different wavelengths into a single fiber. The light from each fiber is first collimated. The collimated beams are then combined using a dichroic filter, with typically the longer wavelength transmitted from port T, the shorter wavelength reflected from port R. The combined beams are then focused into the output fiber at Port 1.

OZ Optics manufactures wave division multiplexors for both telecom and non-telecom applications. Of special interest are our WDMs for combining visible wavelengths. Our RGB multiplexors combine light at red, green and blue wavelengths into singlemode or polarization maintaining fiber. This makes them ideal for applications such as confocal microscopy, white light imaging, full colour holography and others. One advantage of OZ Optics WDM's is that different fiber types can be used on the input and output ends of the device. This is especially useful in fiber amplifier applications, when the Erbium doped fibers have a different core diameter and numerical aperture. WDM's with 1dB typical insertion losses have been made this way. OZ Optics also offers source to fiber wavelength division multiplexors, where the sources are mounted directly onto the device. This improves the overall system efficiency, and reduces costs.

Our miniature size WDMs are ideal for telecommunication applications such as drop/add filters for either coarse WDM (CWDM) or dense DWDM applications. They are also used for combining 980 to 1080nm pump light with 1550nm signals in erbium doped fiber amplifiers (EDFAs).

Laser diode power combiners come in a small, rugged package and are available either with female receptacles to accept different connectors or pigtail style, with the fiber directly attached. Pigtail style combiners are recommended for optimum stability, minimum insertion losses, and low backreflection. Receptacle style systems are best suited for applications where the output coupler is used with a multimode fiber. If a receptacle style combiner is used with a singlemode fiber, then the user may experience low coupling efficiency.

OZ Optics also manufactures polarization maintaining WDM's. The device typically maintains polarization to better than 20dB for 1300 and 1550nm applications. Higher extinction ratios are available on request.

OZ Optics specializes in manufacturing custom designed WDM's. Contact OZ Optics for further information.

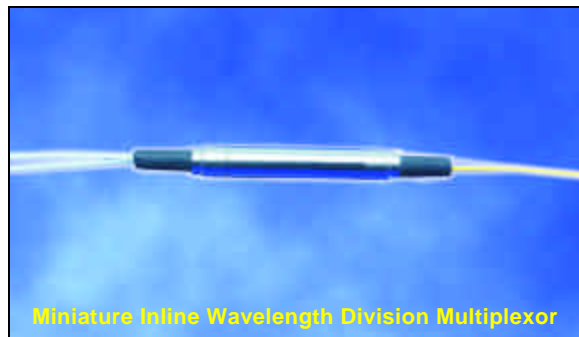

Miniature Inline Wavelength Division Multiplexer

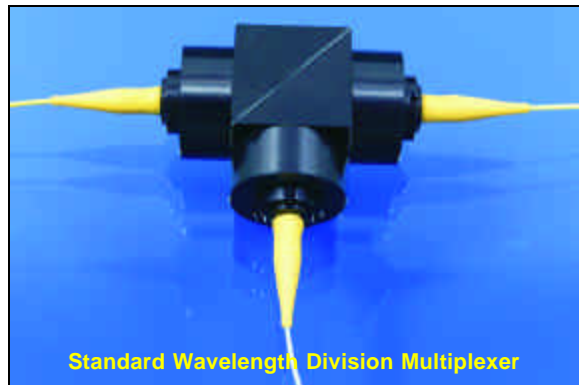

Standard Wavelength Division Multiplexer



RGB Wavelength Division Multiplexer



Laser Diode Power Combiner

### Standard Product Specifications:

Parameter	Units	Condition	Value		
			WDM-12P WDM-13P	WDM-12N CWDM-12N DWDM-12N	WDM-11P
WDM Type			WDM-12P WDM-13P	WDM-12N CWDM-12N DWDM-12N	WDM-11P
Description			Standard Pigtail Style	Miniature Inline Style	Laser Diode Combiner
Available Wavelengths	nm		400-1650	400-1650 <sup>1</sup>	400-1650
Return Losses	dB	400-1200 nm	40	40	40
		1200-1650 nm	40, 50, or 60	40, 50, or 60	40, 50, or 60
Insertion Losses (Typical) <sup>2</sup>	dB	400-1200 nm	1.0	1.0	Not applicable <sup>3</sup>
		1200-1650 nm	0.8	0.8	
Insertion Losses (Maximum) <sup>2</sup>	dB	400-1200 nm	1.2	1.2	Not applicable <sup>3</sup>
		1200-1650 nm	1.0	1.0	
Insertion Losses (60dB Return Loss Option)	dB	1280-1650 nm	0.7 max	0.7 max	Not applicable <sup>3</sup>
Polarization Extinction Ratio	dB	400-600 nm	18	15	18
		600-1150 nm	20	18	20
		1250-1550 nm	20, 25, or 30	20 or 25	20
Power Handling	mW	SM or PM fiber, 1550nm	500 <sup>4</sup>	200 <sup>4</sup>	200 <sup>4</sup>
Operating Temperature	°C		-20 to +60		

<sup>1</sup>Applies to WDM-12N parts only. For CWDM and DWDM parts, available wavelenths range from 180 to 1650nm.

<sup>2</sup>For components whose wavelengths are separated by more than 20nm and less than 200nm

<sup>3</sup>For laser diode power combiners, actual insertion losses depend on the laser diodes selected for the application.

<sup>4</sup>Higher power versions (up to 5 Watts into singlemode fiber, higher into multimode fiber), are available on request.

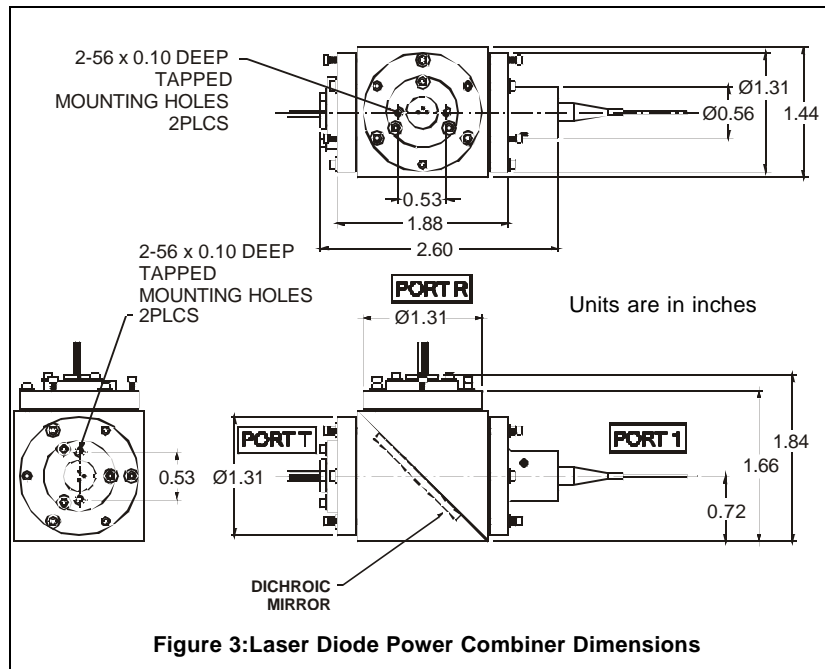
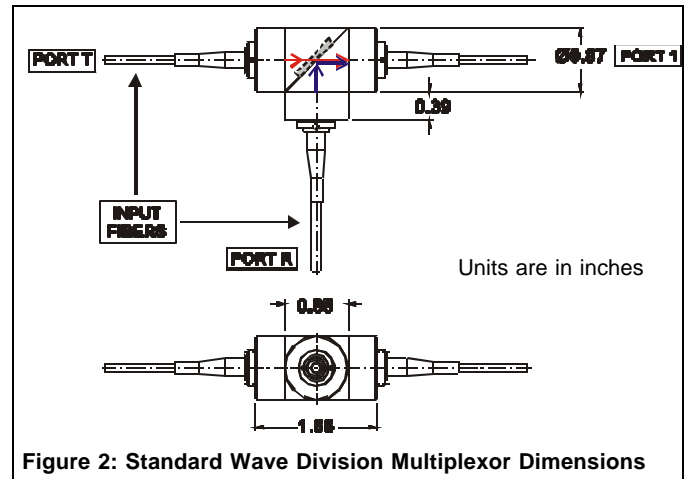
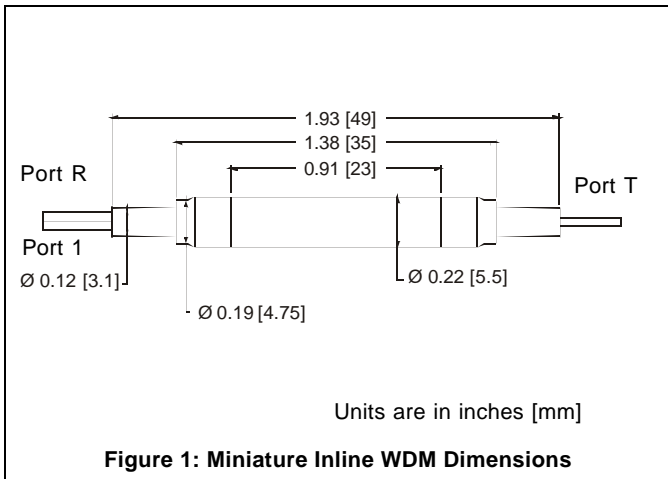

## Ordering Information For Standard Parts:

Bar Code	Part Number	Description
10923	WDM-12P-111-1300/1550-7/125-PPP-60-3U3U3U-3-1	Wavelength division multiplexer for 1300 & 1550nm with 1 meter long, 3mm OD jacketed 7/125 PM fiber pigtails, 60dB return loss and ultra FC/PC connectors.
12808	WDM-12P-111-1480/1550-8/125-PPP-60-3A3A3A-3-1	Wavelength division multiplexer for 1480 & 1550nm with 1 meter long, 3mm OD jacketed 8/125 PM fiber pigtails, 60dB return loss and angled FC/PC connectors.
12809	WDM-12P-111-980/1550-8/125-PPP-40-3A3A3A-3-1	Wavelength division multiplexer for 980 & 1550nm with 1 meter long, 3mm OD jacketed 8/125 PM fiber pigtails, 40dB return loss and angled FC/PC connectors.

## Ordering Information For Custom Parts:

OZ Optics welcomes the opportunity to provide custom designed products to meet your application needs. As with most manufacturers, customized products do take additional effort so please expect some differences in the pricing compared to our standard parts list. In particular, we will need additional time to prepare a comprehensive quotation, and lead times will be longer than normal. In most cases non-recurring engineering (NRE) charges, lot charges, and a 1 piece minimum order will be necessary. These points will be carefully explained in your quotation, so your decision will be as well informed as possible. We strongly recommend buying our standard products.

## Questionnaire For Custom Parts:

- 1) What wavelength range are you interested in?
- 2) What type of fiber is being used? Singlemode, Multimode or PM?
- 3) What power levels are being used in your system?
- 4) What coupling efficiency do you require?
- 5) Are you using a polarized or randomly polarized light source?
- 6) What return losses are acceptable in your system?
- 7) What connector type are you using?
- 8) How do you intend to use this product?

**Note concerning part numbers:** Depending on the configuration of the desired design, the fiber types, lengths, and connectors may be different on each channel. Therefore it is important to correctly identify each port in the proper order. When specifying wavelengths, list them from shortest to longest. When identifying fiber types, start from the shortest wavelength to the longest wavelength, and identify the combined port last. This rule is also used when specifying the connector types and fiber lengths

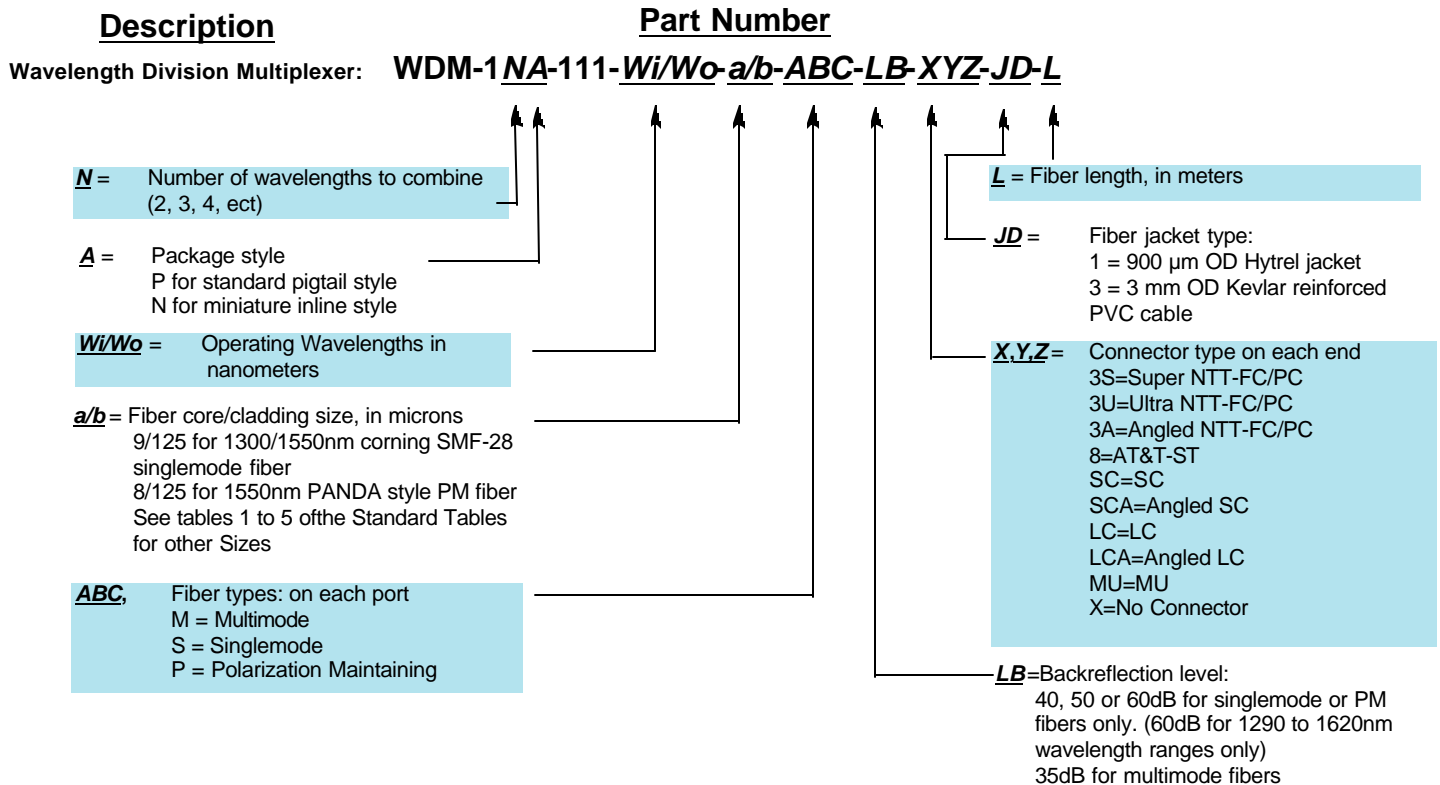

**Pigtail Style Laser Diode Combiner: WDM-11P-a/b-F-Wi/Wo-LB-X-JD-L**

**a/b**= Fiber core/cladding size, in microns  
 9/125 for 1300/1550nm corning SMF-28 singlemode fiber  
 8/125 for 1550nm PANDA style PM fiber  
 See tables 1 to 5 of the Standard Tables for other Sizes

**F** Fiber types: on the output port  
 M = Multimode  
 S = Singlemode  
 P = Polarization Maintaining

**Wi/Wo** = Operating Wavelengths in nanometers

**LB**=Backreflection level:  
 40, 50 or 60dB for singlemode or PM fibers only. (60dB for 1290 to 1620nm wavelength ranges only)  
 35dB for multimode fibers

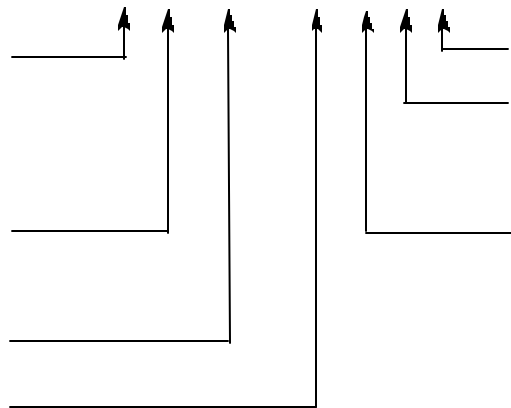

**L** = Fiber length, in meters

**JD** = Fiber jacket type:  
 1 = 900 μm OD Hytel jacket  
 3 = 3 mm OD Kevlar reinforced PVC cable

**X,Y,Z**= Connector type on each end  
 3S=Super NTT-FC/PC  
 3U=Ultra NTT-FC/PC  
 3A=Angled NTT-FC/PC  
 SC=SC  
 SCA=Angled SC  
 LC=LC  
 X=No Connector  
 See table 6 of the standard tables for other connector types

**Frequently Asked Questions (FAQs):**

**Q:** What wavelength ranges are available?

**A:** OZ Optics offers a variety of WDMs working from 400nm to 1650nm. Custom designs are available for combining and splitting most combinations of wavelengths in this region.

**Q:** Can I use different fibers on each port?

**A:** Yes, OZ Optics WDM design offers the flexibility of having different fiber types on each of the ports.

**Q:** Can I use high power with these WDMs?

**A:** Yes, OZ Optics standard design can handle up to 200mW, for higher power applications a custom design can be done to handle up to 2W.

**Q:** What is the standard package size? Can I get a smaller package?

**A:** The standard packages for WDMs use a 0.8 or 1.6 inch cube design. These packages are ideal for low cost proto-type applications. For OEM applications OZ Optics will work with you to design a package that meets your size requirements.

**Q:** Do you offer WDM's that can combine more than two wavelengths?

**A:** Yes. Systems that combine 3 and 4 different wavelengths have also been made.

**Application Notes:**

Wavelength Division Multiplexers (WDM) are used to combine and split (multiplex and demultiplex) signals in different systems ranging from telecommunications to imaging systems. The basic principle of WDM is based on thin film filters that transmit light in a certain spectral range and reflect light in another spectral range. Figure 3 below demonstrates the basic principle of splitting and combining two different wavelengths.

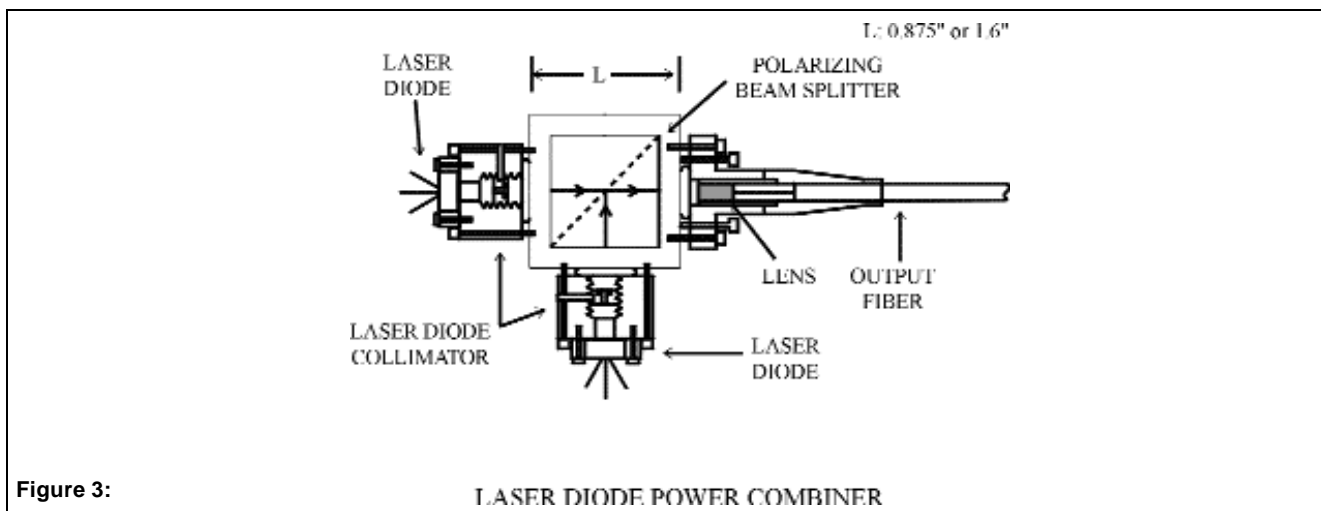

**Figure 3:** LASER DIODE POWER COMBINER

The WDM plate is designed to transmit  $\lambda_1$  and reflect  $\lambda_2$  thereby "multiplexing" the two inputs into the common port. Due to the inherent bi-directional nature of the filter, this component will also work in the opposite direction in order to "de-multiplex" the two wavelengths.