

YVO₄ - Yttrium Orthovanadate

Introduction

Yttrium Orthovanadate (YVO₄) is a positive uniaxial crystal grown with Czochralski method. It has good temperature stability, physical and mechanical properties. It is ideal for optical polarizing components because of its wide transparency range and large birefringence. It is an excellent synthetic substitute for Calcite (CaCO₃) and Rutile (TiO₂) crystals in many applications including fiber optic isolators and circulators, interleavers, beam displacers and other polarizing optics (refer to Table 1).

Table 1. Comparison of Basic Properties Between YVO₄ and Other Birefringent Crystals

		YVO ₄	TiO ₂	CaCO ₃	LiNbO ₃
Thermal Expansion (/°C)	c-axis	11.4×10^{-6}	9.2×10^{-6}	26.3×10^{-6}	16.7×10^{-6}
	a-axis	4.4×10^{-6}	7.1×10^{-6}	5.4×10^{-6}	7×10^{-6}
Refractive Index	n _o	1.9447 @1550 nm	2.454 @1530 nm	1.6346 @1497 nm	2.2151 @1440 nm
	n _e	2.1486 @1550 nm	2.710 @1530 nm	1.4774 @1497 nm	2.1413 @1440 nm
Birefringence (n _e -n _o)		0.2039 @1550 nm	0.256 @1530 nm	-0.1572 @1497 nm	-0.0738 @1440 nm
Mohs Hardness		5	6.5	3	5
Deliquescence		None	None	Weak	None
Transparency Range		0.4-5 μm	0.4-5 μm	0.35-2.3 μm	0.4-5 μm

A reliable supplier of YVO₄ crystals

CASTECH is one of the earliest companies who have mastered the advanced growth technique of YVO₄ crystal and completed its strong mass-production line that can provides:

- Various size of bulk and finished high quality YVO₄ crystals up to Φ35 x 50 mm³ and Φ20 x 20 mm³, respectively;
- Large quantity YVO₄ wedges and displacers used for fiber optical isolators and circulators, interleavers, in size of 1.25 x 1.25 x 0.5 mm³ to 3 x 3 x 15 mm³ to meet OEM customer's requirement;
- Quick delivery;
- Competitive price;
- Strict quality control;
- Technical support.

Table 2. Basic Properties

Transparency Range	High transmittance from 0.4 to 5 μm
Crystal Structure	Zircon Tetragonal, space group D_{4h}
Lattice Parameter	$a = b = 7.12 \text{ \AA}$; $c = 6.29 \text{ \AA}$
Density	4.22 g/cm^3
Mohs Hardness	5, glass-like
Hygroscopic Susceptibility	Non-hygroscopic
Thermal Expansion Coefficient	$\alpha_a = 4.43 \times 10^{-6} / \text{K}$; $\alpha_c = 11.37 \times 10^{-6} / \text{K}$
Thermal Conductivity Coefficient	// C: 5.23 W/m/K; \perp C: 5.10 W/m/K
Thermal Optical Coefficient	$dn_d/dT = 8.5 \times 10^{-6} / \text{K}$; $dn_c/dT = 3.0 \times 10^{-6} / \text{K}$
Crystal Class	Positive uniaxial with $n_o = n_a = n_b$, $n_e = n_c$
Refractive Indices, Birefringence ($\Delta n = n_e - n_o$) and Walk-off Angle at 45° (ρ)	$n_o = 1.9929$, $n_e = 2.2154$, $\Delta n = 0.2225$, $\rho = 6.04^\circ$ at 630 nm $n_o = 1.9500$, $n_e = 2.1554$, $\Delta n = 0.2054$, $\rho = 5.72^\circ$ at 1300 nm $n_o = 1.9447$, $n_e = 2.1486$, $\Delta n = 0.2039$, $\rho = 5.69^\circ$ at 550 nm
Sellmeier Equation (λ in μm)	$n_o^2 = 3.77834 + 0.069736 / (\lambda^2 - 0.04724) - 0.0108133 \lambda^2$ $n_e^2 = 4.59905 + 0.110534 / (\lambda^2 - 0.04813) - 0.0122676 \lambda^2$

Applications

YVO_4 crystals are widely used in fiber-optic isolators, beam displacers and optical circulators, etc.

Table 3. Specifications of Birefringent Wedges for Fiber-Optic Isolators

Aperture	$1.0 \times 1.0 \text{ mm}^2$ to $4 \times 4 \text{ mm}^2$
Dimension Tolerance	$\pm 0.1 \text{ mm}$
Wedge Angle Tolerance	$\pm 0.1^\circ$
Optical Axis Orientation	$\pm 0.5^\circ$
Flatness	$\lambda/4$ @633 nm
Surface Quality (Scratch/Dig)	20/10 to MIL-PRF-13830B
AR-Coating	$R < 0.2\%$ @1550 or 1310 nm
Standard Size	$1.25 \text{ mm} \times 1.25 \text{ mm} \times 0.5 \text{ mm}$ with 13° or 15° wedge, $\phi = 22.5^\circ$

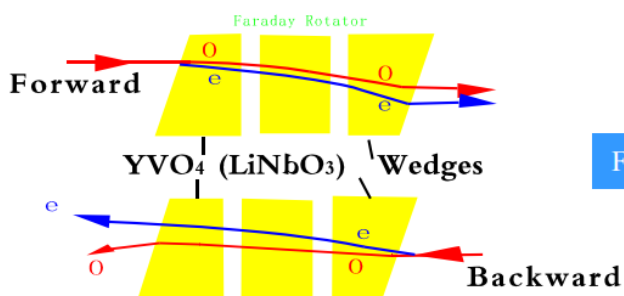
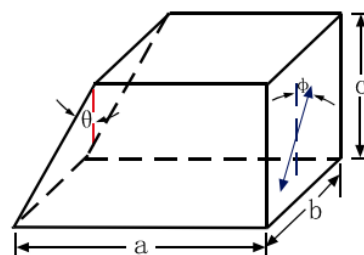

Fiber Optical Isolator

Table 4. Specifications of YVO₄ Beam Displacers for Fiber-Optic Circulators or Interleaver

Dimension Tolerance	$(W \pm 0.05 \text{ mm}) \times (H \pm 0.05 \text{ mm}) \times (L \pm 0.1 \text{ mm})$
Optical Axis Orientation	$\pm 0.5^\circ$
Parallelism	20 arc sec
Perpendicularity	≤ 15 arc min
Flatness	$\lambda/4$ @633 nm
Surface Quality (Scratch/Dig)	20/10 to MIL-PRF-13830B
AR-Coating	$R < 0.2\%$ @1550 nm or $1310 \text{ nm} \pm 40 \text{ nm}$
Standard Size	$2.6 \times 2.6 \times 10 \text{ mm}^3, \theta = 45^\circ, \Phi = 0^\circ$

Note: Other sizes and specifications are available upon request.

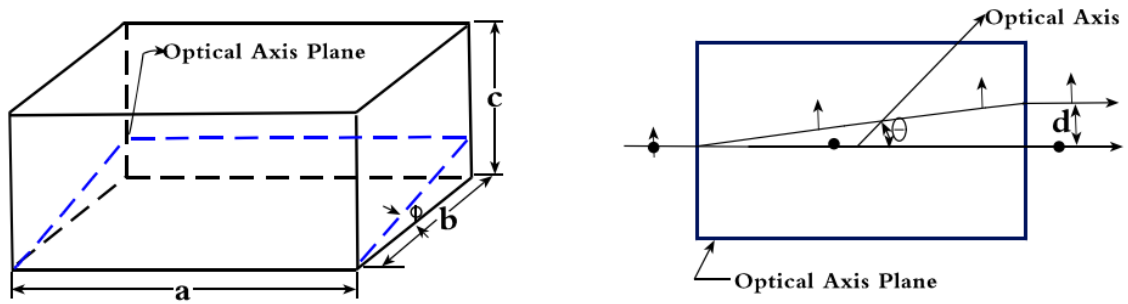
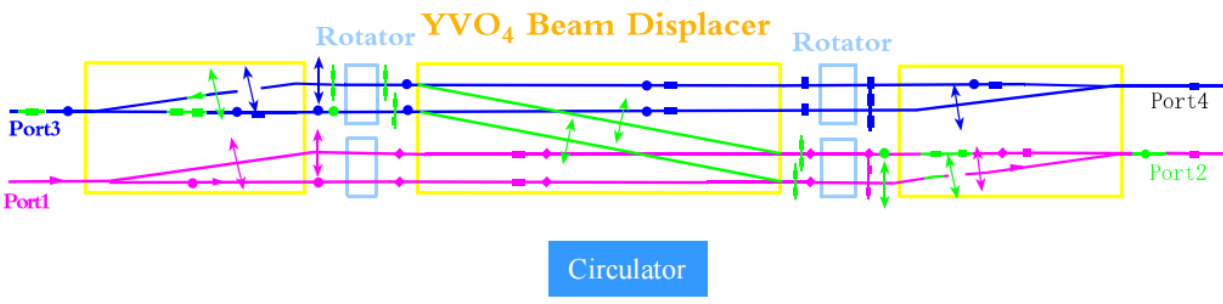

YVO₄ Beam Displacer for Circulator