

Integrated 100-Gb/s DP-QPSK Coherent Receiver

The integrated 100-Gb/s DP-QPSK receiver incorporates two 90° optical hybrids with four pairs of balanced photodetector (PD) and four linear TIAs into a single butterfly package. Unlike other technologies in which the polarization beam splitter (PBS) and/or the power splitter (BS) are not included, Optoplex's receiver includes both of them with the optical hybrids, PDs and the TIAs to offer a fully integrated solution which will benefit users in terms of completely removing fiber routing and the skew management. The integrated receivers work at the symbol rate up to 32GBaud/s.

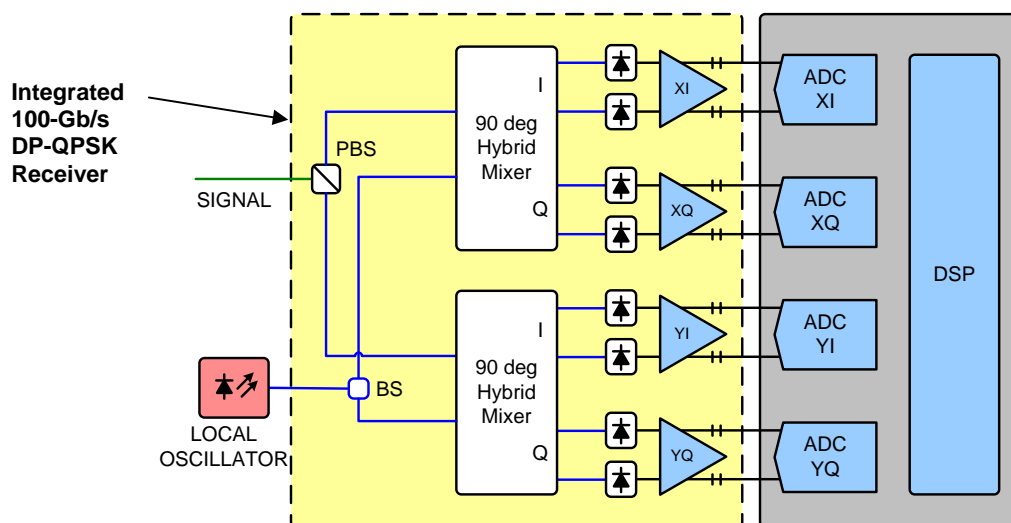

From oif2009.033.05

Optoplex's integrated 100-Gb/s DP-QPSK Coherent Receiver is compatible with OIF's Implementation Agreement (IA) for Integrated Intradyned Coherent Receivers (OIF2009.033.04). The actual mechanical dimension is $50 \times 27 \times 7.5$ mm (shorter and thinner than OIF's maximum allowable dimensions). The high-speed electrical interfaces (RF Outputs) uses co-planar waveguides (CPW) as proposed in OIF's IA. The low-speed electrical interface (DC Control Pins) uses 40 pins and the same arrangement as specified in OIF2009.033.05 IA.

Key Features and Benefits

- Fully compliant with OIF requirements
- Built-in PBS and BS
- Small skew
- Low phase error
- High CMRR

Applications

- Optical coherent detection
- DP-QPSK demodulation
- 100Gb/s transmission (preferred choice of modulation format)



Optical-Electrical Performance Specification

Parameter		Unit	Min	Typ	Max
Frequency Range	C-Band	THz	191.5		196.2
	L-Band	THz	186.0		191.5
Symbol Rate		GBaud			32
Signal Power: Operating Range		dBm	-18	-10	0
Local Oscillator Power		dBm	(Refer to detail spec. Ask Optoplex for the info)		
Linear Output Swing Adjustment Range	Standard	mVppd	300	500	700
	Extended	mVppd	400		900
Maximum Gain Control Bandwidth		MHz		5	
Total Harmonic Distortion (THD) [DC current = 1.6mA; AC = 0.36mApp in to each PD V _{OUTDIFF} = 500mVpp; F _{IN} = 1GHz ± 10%]		%			5
Common Mode Rejection Ratio (CMRR _{DC})	Signal to I & Q	dB			-20
	LO to I & Q	dB			-12
Common Mode Rejection Ratio (CMRR _{22GHz})	Signal to I & Q				-16
	LO to I & Q				-10
Small Signal Bandwidth		GHz		22	
Low Frequency Cut-off		kHz			100
Phase Error		deg			±5
Optical Reflectance		dB	-27		
Output Electrical Return Loss (S ₂₂)	$f < 20\text{GHz}$	dB	10		
	$16\text{GHz} < f < 24\text{GHz}$		8		
	$24\text{GHz} < f < 32\text{GHz}$		6		
Skew: p, n		ps			1
Channel Skew		ps			5
Channel Skew Variation		ps			2
Max Optical Input Power		mW			300

- Notes:**
1. For OIF detailed requirements, please refer to OIF2009.033.05
 2. Contact sales@optoplex.com for detail specification

Optoplex Corporation, located in Fremont, California, is an ISO9001:2000 certified supplier of cutting-edge photonic components and modules for dynamic wavelength management and signal conditioning. The company designs, develops, manufactures, and markets innovative fiber-optic products to communications networks, and provides customized solutions to instrument, defense, spectroscopy and sensing industries. By combining its proprietary optical design and packaging technology with its state-of-the-art optical coating expertise and facility, Optoplex supplies DPSK demodulators, DQPSK demodulators, 90° optical hybrids, 2-port tunable optical filters, 3-port reconfigurable optical add/drop multiplexers (ROADMs), optical interleavers, flat-top comb filters, optical performance monitors (OPMs), and portable spectrometers.