



**CBL07131816NVP**

---

**7-13 GHz Low noise amplifier  
QFN MMIC**

## General description

The CBL07131816NVP is a low noise amplifier MMIC operating in the frequency range 7 to 13 GHz. The device is packaged in a 3x3 mm 16 lead Plastic Surface Mount Package (ROHS).

The device has a linear gain of 18 dB and a typical noise figure of 1.6 dB. Typical operating supply current is only 70 mA with a supply voltage at +5 V. It is manufactured on a PHEMT Technology and is especially suited for radar and for telecommunication applications.

## Applications

- Telecommunications
- Radar Meteo / Survey
- Test and measurements

## Features

- Operating frequency range : 7 to 13 GHz
- Gain : 18 dB
- Noise figure : 1.6 dB
- Gain Flatness : +/- 1 dB
- Input Return Loss: -14 dB typ.
- Output Return Loss: -12 dB typ.
- Power supply: 70 mA @ +5 V
- Package : QFN 3x3 mm 16 Lead

## Tools

S2P file can be provided for system design simulation. DXF drawing file is available for mechanical design. Evaluation board available on request.

## Ordering information

Product code	Definition
CBL07131816NVP	QFN 3x3 mm 16 Lead LNA

## Functional diagram / Pinout

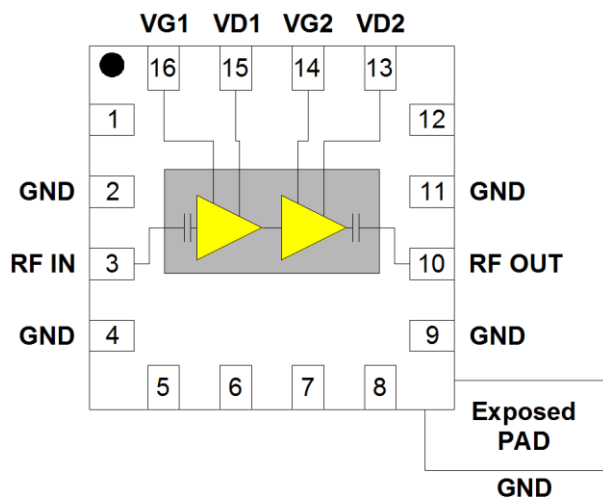

PINOUT			
PIN	Name	PIN	Name
1	NC	9	GND
2	GND	10	RF OUT
3	RF IN	11	GND
4	GND	12	NC
5	NC	13	VD2
6	NC	14	VG2
7	NC	15	VD1
8	NC	16	VG1

## Typical Characteristics (Ambient temperature T= 25°C)

Operating conditions:

$$VD = VG1 = VD1 = VG2 = VD2 = +5V$$

$$\text{Typically } I_{\text{Total}} = IG1 + ID1 + IG2 + ID2 = 70\text{mA}$$

Measured parameters	Symbol	Min	Typ	Max	Unit
Frequency range	F	7		13	GHz
Linear gain	G		18		dB
Small signal gain flatness	$\Delta G$		+/-1		dB
Noise Figure	NF		1.6		dB
Output power at 1dB compression	P1dBc		9		dBm
Input Reflection coefficient	S11		-14		dB
Output Reflection coefficient	S22		-12		dB
Operating supply voltage	VD1_2, VG1_2		5		V
Supply current	$I_{\text{Total}}$		70		mA

## Absolute maximum ratings



Maximum ratings	Symbols	Min	Max	Units
Drain voltage	VD1_2		+6	V
Gate voltage	VG1_2		+6	V
Supply current	$I_{\text{Total}}$		90	mA
CW Input Power	Pin		+20	dBm
Storage temperature	Tst	-55	+125	°C
Operating temperature	Top	-40	+85	°C
Channel temperature	Tch		+150	°C

Operation of this device above any of these parameters may cause permanent damages.

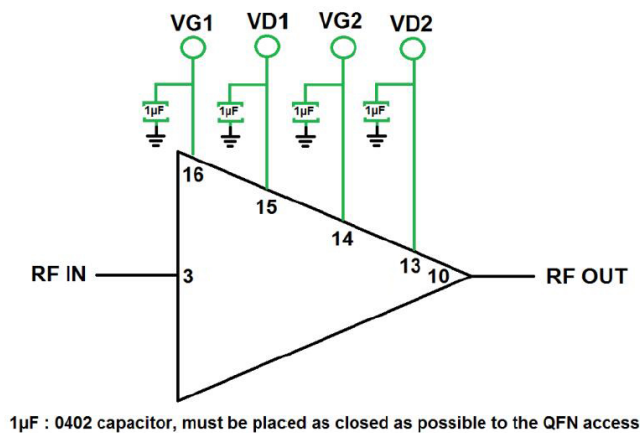
## Application circuit

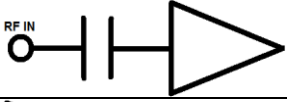
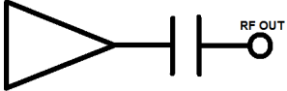
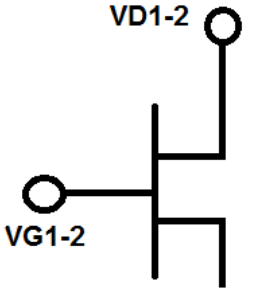

## Pin description

Pin number	Name	Description	Electrical interface
3	RFin	AC coupled, amplifier input access. Internally matched 50 Ohms.	
10	RFout	AC coupled amplifier output access. Internally matched 50 Ohms.	
13, 15	VD2, VD1 (*)	1rst stage and second stage drain biasing access. External 1µF 0402 decoupling capacitor are required on each VD access if use independently.	
16, 14	VG2, VG1 (*)	1rst stage and second stage gate biasing access. External 1µF 0402 decoupling capacitor are required on each VG access if use independently.	
Exposed PAD	GND	Ground paddle must be connected to HF and DC Ground	
2, 4, 9, 11	GND	This PINS must be connected to HF and DC Ground	

(\*) : if a single supply voltage is used for VD1, VG1, VG2, VD2, only one external 1µF 0402 decoupling capacitor is required for all the accesses.

## Typical performances measurements (Ambient temperature T= 25°C)

Operating conditions:

VD = VG1 = VD1 = VG2 = VD2 = +5V

Typically  $I_{Total} = I_{G1} + I_{D1} + I_{G2} + I_{D2} = 70\text{mA}$

Measurement at SMA connectors

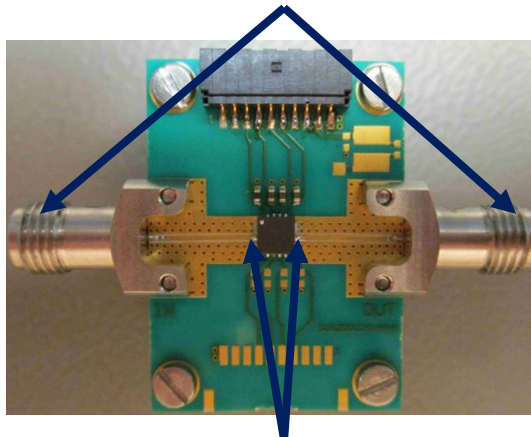

Measurement reference plane at the component.

**S-parameters (dB)**

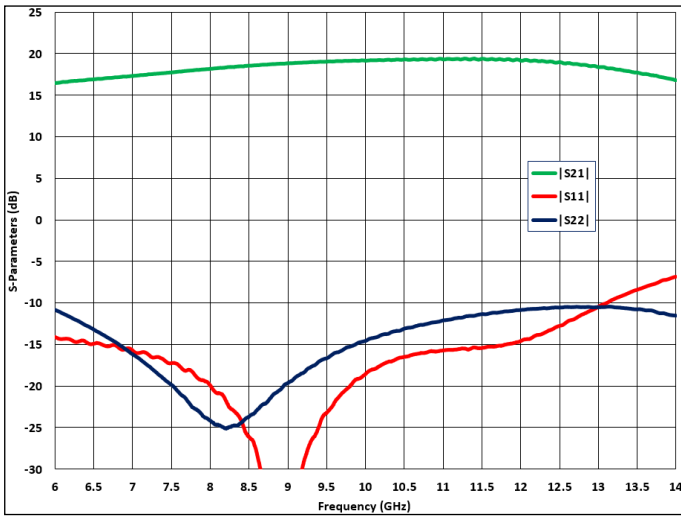

**Gain (dB)**

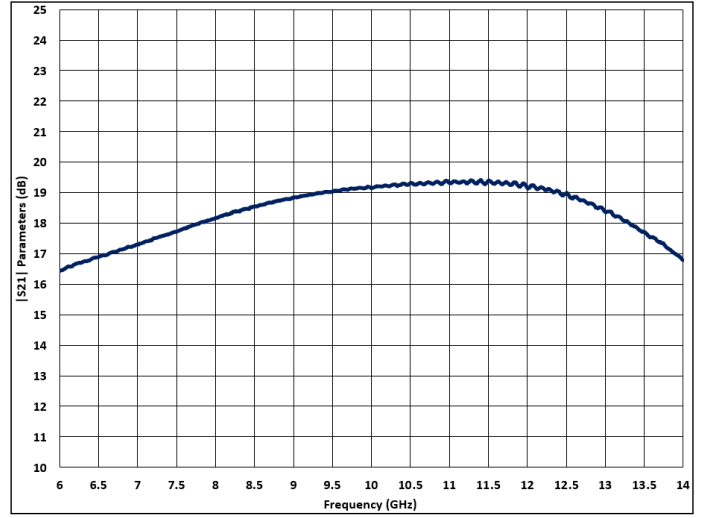

**Noise Figure (dB):**

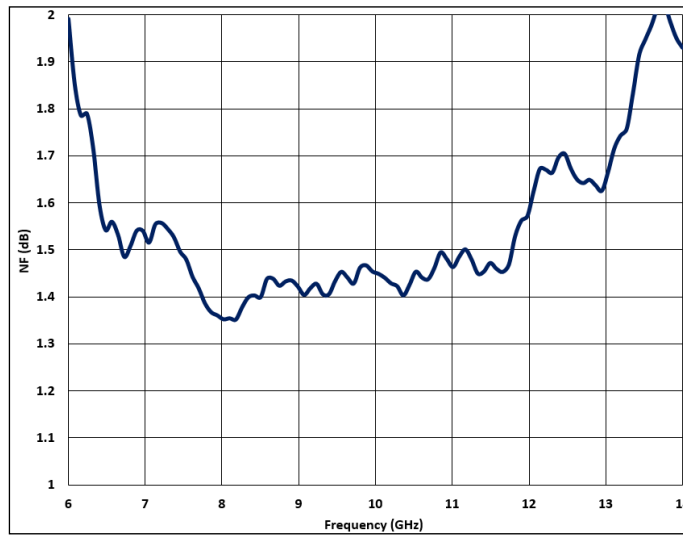

**Output power VS Input Power :**

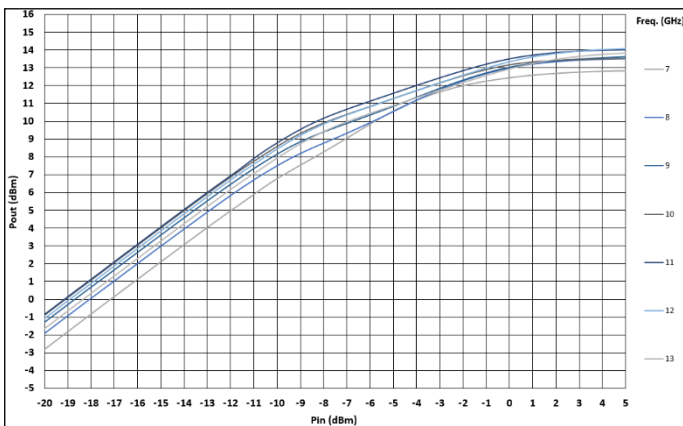

**Total current VS Input power**

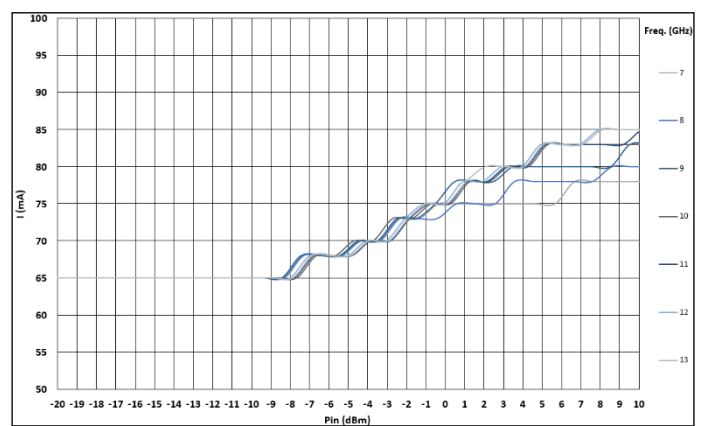

## Biasing

### Switch on

1. Set VD1, VD2, VG1 and VG2 to +5V
2. optional: VG1 and VG2 can be tuned between 0V and +5V (will reduce supply current but will affect other electrical parameters)
3. Turn RF ON

### Switch off

1. Turn RF OFF
2. Decrease VD1, VD2, VG1 and VG2 to 0V

## Mechanical Drawing

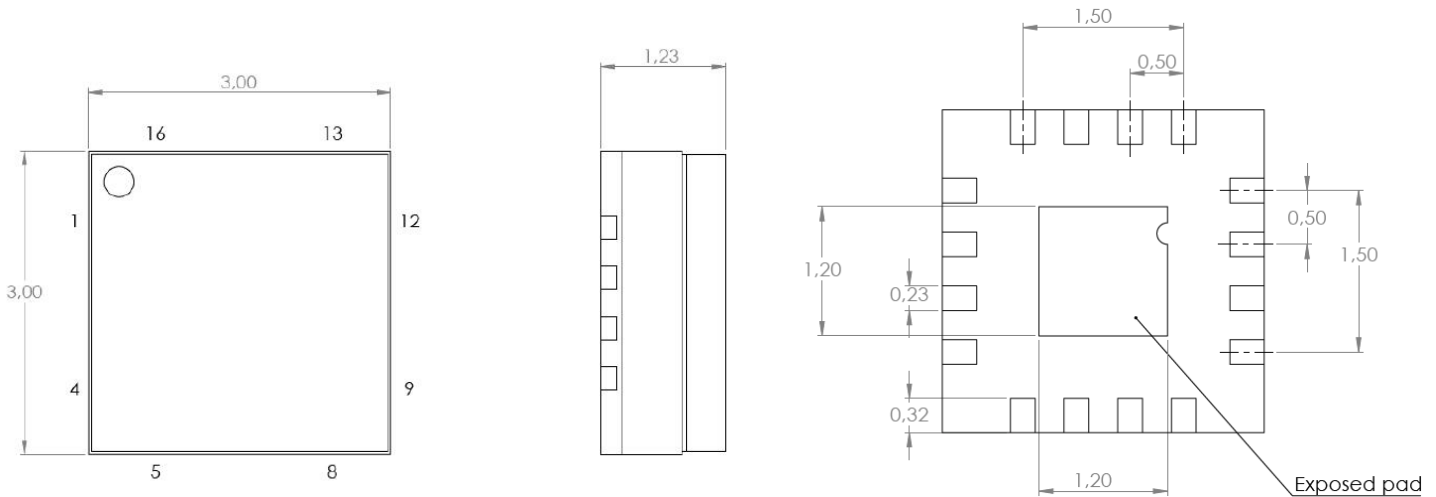

- QFN exposed PAD must be connected to ground (RF and DC).

### Recommended Land pattern

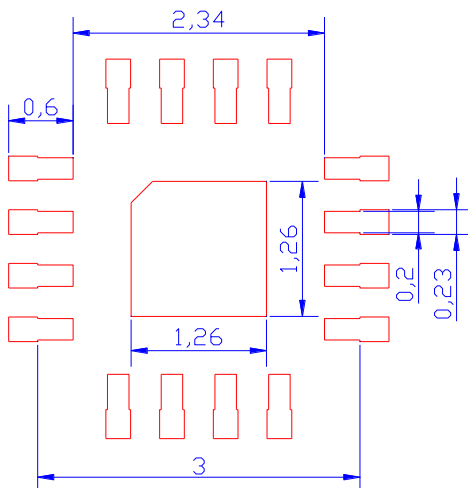

### Suggested Board Layout

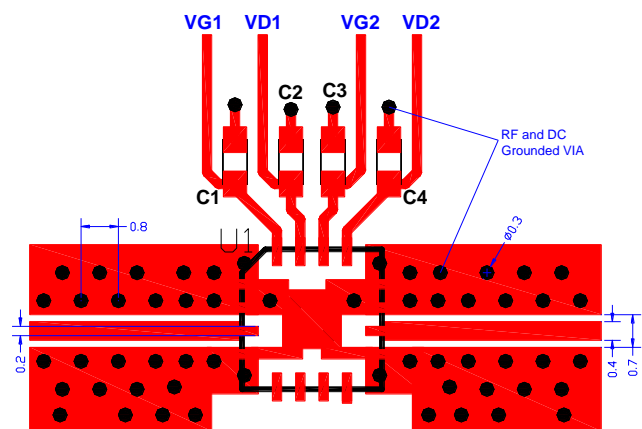

C1, C2, C3, C4 : 0402 1 $\mu$ F/16V capacitor

Substrate : RO4350B, thickness 0.254mm

## Soldering recommendation

Solder Stencil thickness : 127µm  
Solder : SAC 305 (ROHS)

Temperature profile example : maximum recommended reflow profile (leadfree)

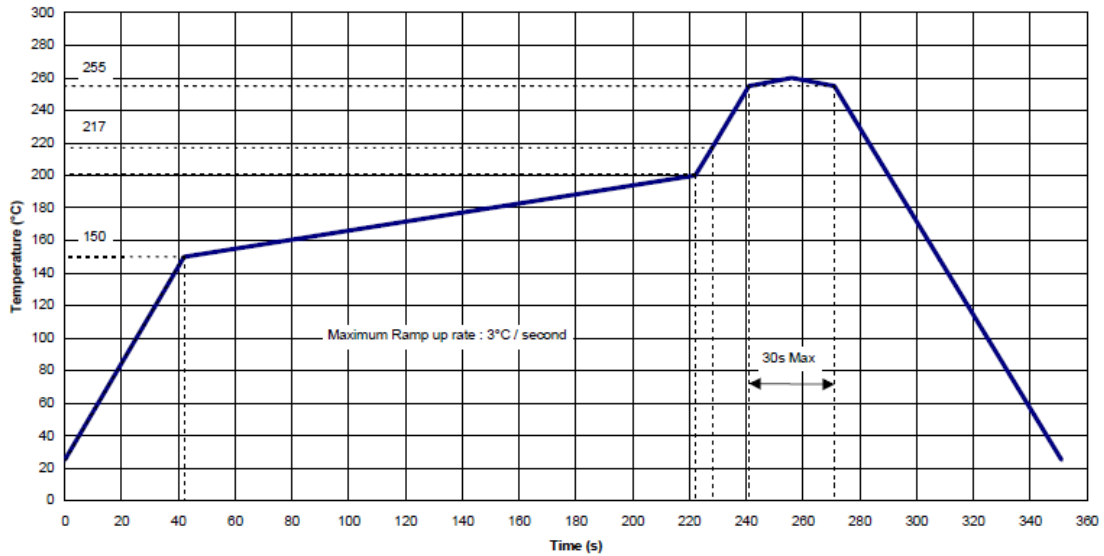

Figure 1: Temperature reflow profile example

## Handling

This product is sensitive to electrostatic discharge and should not be handled except at a static free workstation. Take precautions to prevent ESD; use wrist straps, grounded work surfaces and recognized anti-static techniques when handling the CBL07131816NVP device.

