

BOA 1132: O-band Booster Optical Amplifier

7.1.2.SP.1132 Rev B

Engineering Models / Limited Warranty

Description

The BOA 1132 is a high saturation output power high bandwidth polarization maintaining Booster Optical Amplifier (BOA). It incorporates a highly efficient InP/InGaAsP Quantum Well (QW) layer structure and a reliable ridge waveguide design.

It is housed in a standard 14 pin butterfly package with integrated thermoelectric cooler and thermistor. Packaging options include isolator(s) and choice of single mode fiber and polarization maintaining fiber tails.

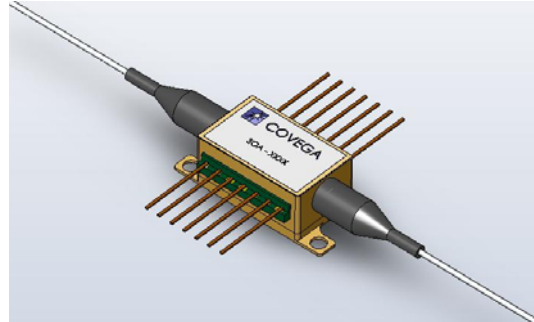

Features

Applications

- ✓ Telecom & Datacom
- ✓ Booster Amplifier of Fixed and Tunable ITU Lasers and Transmitters
- ✓ Research & Non-Linear Applications

- High Saturation Output Power
- Broad Spectral Bandwidth
- High Fiber-to-Fiber Gain
- High Polarization Extinction Ratio

Specifications

CW; T (Chip) = 25°C, T (Case) = 0 - 70°C

Parameter		Min	Typ	Max	
Operating Current	I_{OP}		600	750	mA
Central Wavelength	λ_C	1290	1300	1313	nm
Optical 3 dB Bandwidth	BW	70	75		nm
Saturation Output Power @ -3 dB	P_{SAT}	12	15		dBm
Small Signal Gain across BW @ Pin = -20 dBm	G	17	20		dB
Gain Ripple (p-p) @ I_{OP}	δG		0.3	0.6	dB
Noise Figure	NF		7	9	dB
Forward Voltage	V_F		1.4	2.0	V
TEC Operation (typ / max @ $T_{CASE} = 25^\circ C / 70^\circ C$)					
- TEC Current	I_{TEC}		0.15	1.5	A
- TEC Voltage	V_{TEC}		0.35	4.0	V
- Thermistor Resistance	R_{TH}		10K		Ω

SPECIFICATIONS SUBJECT TO CHANGE WITHOUT NOTICE

BOA 1132

Performance

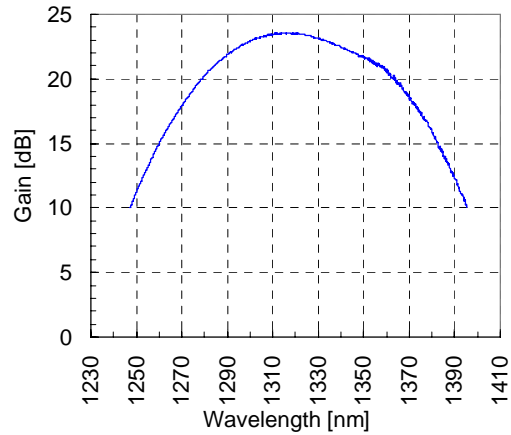
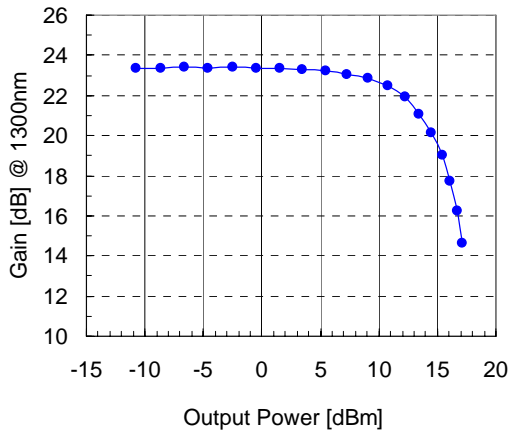

Packaging

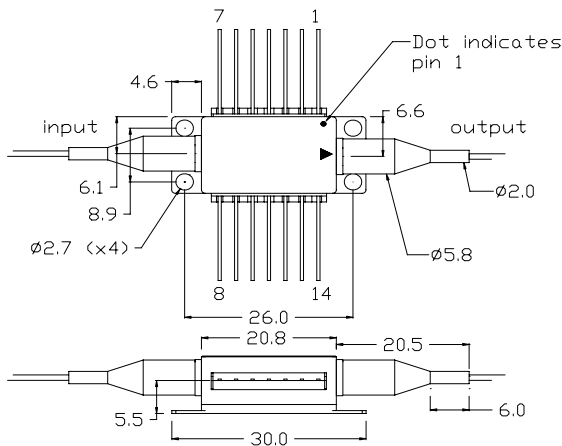

PIN IDENTIFICATION

- | | |
|---------------|-----------------|
| 1. TEC + | 14. TEC - |
| 2. Thermistor | 13. Case |
| 3. NC | 12. NC |
| 4. NC | 11. SDA Cathode |
| 5. Thermistor | 10. SDA Anode |
| 6. NC | 9. NC |
| 7. NC | 8. NC |

Recommended mounting torque is 10-20oz.in (0.07-0.14N.m).

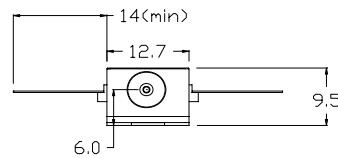

Ordering Information

BOA 1132 - X - 0 - X - X - X - X - X							
X	0	X	X	X	X	X	Numeric
Isolator	Reserved	Fiber jacket configuration*	Input Fiber	Output Fiber	Input Connector	Output Connector	Reserved
0 = none		U = SMF-28, loose tube	S = SMF	S = SMF	B = Bare Fiber	B = Bare Fiber	
1 = input only		T = SMF-28, tight jacket	P = PMF	P = PMF	A = FC/APC	A = FC/APC	1 = Reserved
2 = output only		W = PMF 1300 nm, loose tube			O = Other	O = Other	2 = Reserved
3 = input & output							

* see separate fibertail options datasheet

© Covega Corporation - All rights reserved