

FEATURES

- Specific design for pulse signals
- Accommodate a variety of pulse formats
- High pulse fidelity

APPLICATIONS

- Pulse generation
- Pulse picking
- Spectroscopy
- Lidar

OPTIONS

- Heat-sink
- Custom design: higher PW, lower PRF

The Photline DR-PL-10-MO RF drivers are amplifiers module designed to drive LiNbO_3 optical modulators so as to generate undistorted optical pulses.

Electrical pulsed signals differ from classical telecom signals by long periods with no signal, when telecom signals are usually well balanced in 1 and 0. They also differ from analog signal by a wider frequency content. In order to generate clean optical pulses with sharp edges, sustained high and low levels and no overshoot, pulsed signals do require specific amplifiers.

The Photline DR-PL-10-MO driver is optimized for low and high Pulse Repetition Frequency (PRF) signals from 10 Hz to GHz. The bandwidth up to 10 GHz accommodates 100 ps narrow pulse width with short rise and fall time (down to 25 ps) and can withstand longer pulses up to 100 ns.

The Photline DR-PL-10-MO drivers come in compact connectorized modules that match directly with Photline modulators, they use a single voltage power supply for ease and safety of use and feature an output voltage control for maximum flexibility. An optional heat sink is proposed as an accessory.

Performance Highlights

Parameter	Min	Typ	Max	Unit
Cut-off frequencies	45 k	-	8 G	Hz
Output pulse amplitude	2.5	-	8.5	V_{pp}
Gain	-	21	-	dB
Pulse repetition frequency	10	-	1 G	Hz
Pulse width	100 p	-	100 n	s
Rise / Fall time	-	40	-	ps

DC Electrical Characteristics

Parameter	Symbol	Min	Typ	Max	Unit
Supply voltage (fixed)	V_{bias}	9	12	13	V
Driver Supply Current	I_{bias}	-	300	400	mA
Gain control voltage	V_{amp}	0	0.25	0.9	V

Electrical Characteristics

Parameter	Symbol	Condition	Min	Typ	Max	Unit
Lower frequency	$f_{3dB, lower}$	-3 dB point	45	50	-	kHz
Upper frequency	$f_{3dB, upper}$	-3 dB point	6	8	-	GHz
Gain	S_{21}	Small signal, $P_{in} = -30$ dBm	-	21	-	dB
Gain ripple	-	< 7 GHz	-	± 1.5	-	dB
Input / Output return loss	S_{11} / S_{22}	50 kHz < f < 10 GHz	-	-10	-	dB
Output pulse amplitude	V_{out}	$V_{in} = 300$ mV _{pp}	2.5	5	8	V _{pp}
Sat output pulse amplitude	V_{out}	$V_{in} = 500$ mV _{pp}	-	-	8.5	V _{pp}
Pulse repetition frequency	PRF	100 ps < PW < 100 ns	10	-	1 G	Hz
Pulse width	PW	10 Hz < PRF < 1 GHz	100 p	-	100 n	s
Rise / Fall time	t_r / t_f	20 % - 80 %	-	25	30	ps
Delay time	D_t	-	-	400	-	ps
Power dissipation	P	-	-	3.6	5.2	W

Conditions: S parameters -30 dBm, $T_{amb} = 25^\circ\text{C}$, 50 Ω system

Absolute Maximum Ratings

Stresses in excess of the absolute maximum ratings can cause permanent damage to the device. These are absolute stress ratings only. Functional operation of the device is not implied at these or any other conditions in excess of those given in the operational sections of the data sheet. Exposure to absolute maximum ratings for extended periods can adversely affect device reliability.

Parameter	Symbol	Min	Max	Unit
RF input voltage	V_{in}	-	0.5	V _{pp}
Supply voltage	V_{bias}	0	13	V
DC current	I_{bias}	0	400	mA
Gain control voltage	V_{amp}	0	0.9	V
Power dissipation	P_{diss}	-	5.2	W
Temperature of operation	T_{op}	-5	+50	W
Storage temperature	T_{st}	-40	+70	$^\circ\text{C}$

S_{21} Parameter Curve

Conditions: $V_{bias} = 12\text{ V}$, $V_{amp} = 0.47\text{ V}$, $I_{bias} = 350\text{ mA}$

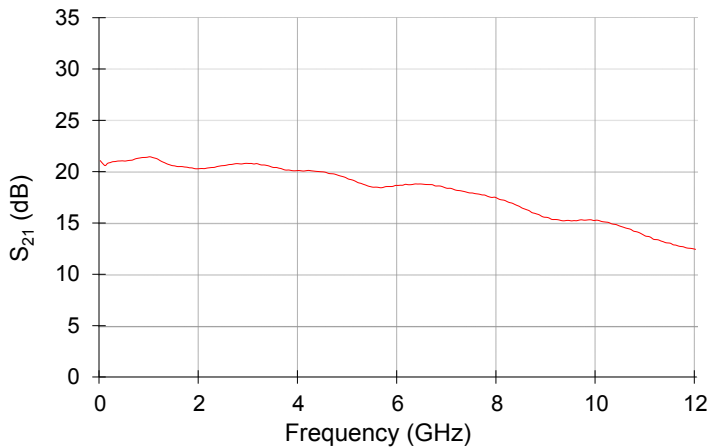

Group Delay Parameter Curve

Conditions: $V_{bias} = 12\text{ V}$, $V_{amp} = 0.47\text{ V}$, $I_{bias} = 350\text{ mA}$

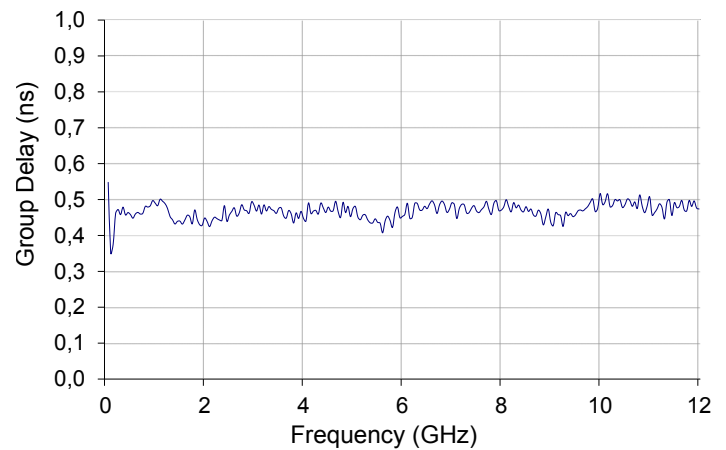

S_{22} Parameter Curve

Conditions: $V_{bias} = 12\text{ V}$, $V_{amp} = 0.47\text{ V}$, $I_{bias} = 350\text{ mA}$

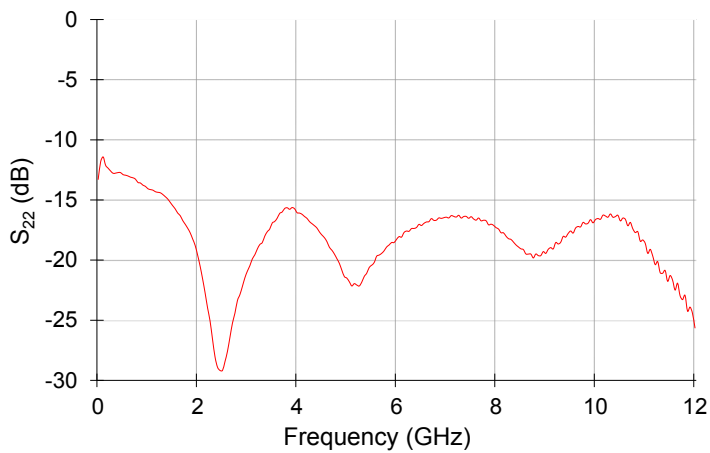

S_{11} Parameter Curve

Conditions: $V_{bias} = 12\text{ V}$, $V_{amp} = 0.47\text{ V}$, $I_{bias} = 350\text{ mA}$

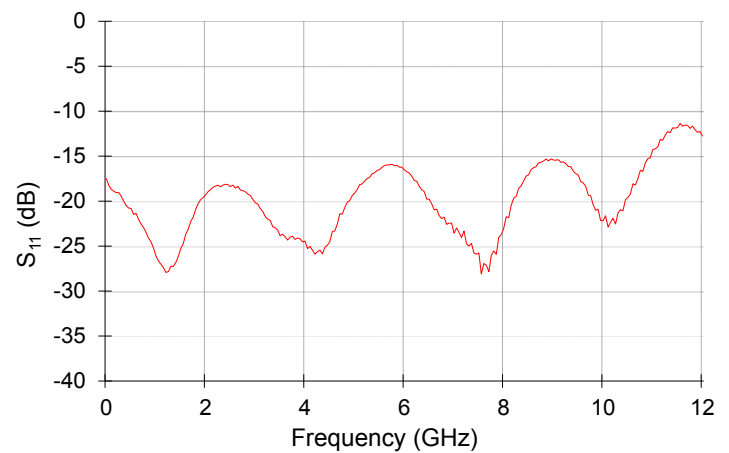

S_{12} Parameter Curve

Conditions: $V_{bias} = 12\text{ V}$, $V_{amp} = 0.47\text{ V}$, $I_{bias} = 350\text{ mA}$

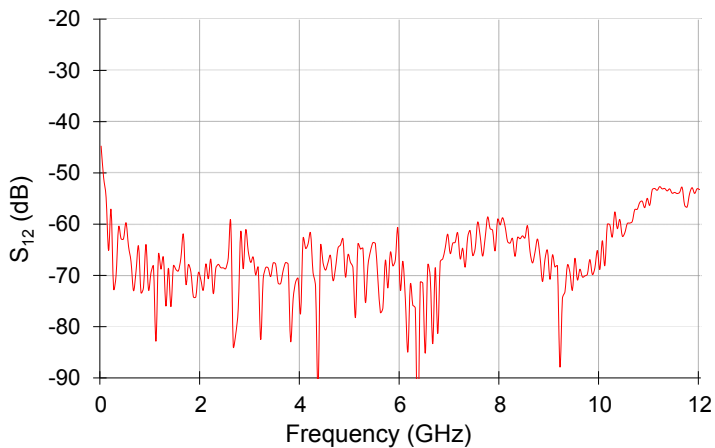

Typical Output Voltage Amplitude vs V_{amp}

Conditions: $V_{bias} = 12\text{ V}$, $V_{in} = 0.3\text{ V}_{pp}$

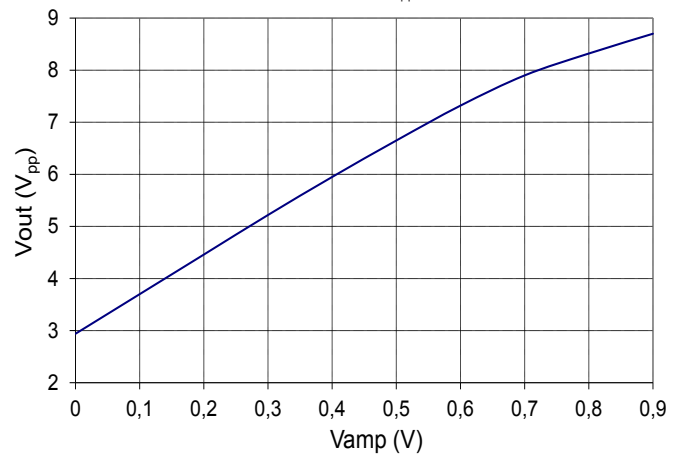

Pulses Measurements

Conditions: Input signal

The input electrical signal is generated by Anritsu MP1800A. Measured using Agilent 86100B with two 50 GHz 8348A channels module, and the output optical signal measured using Agilent 86100B with two 50 GHz 8348A channels module.

Low frequency repetition rate width wide pulse width: PW = 100 ps, PRF = 100 MHz

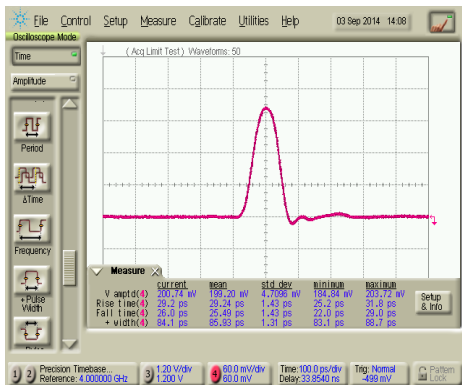

Input signal: Pulse amplitude = 0.200 V_{pp}, Rise time = 29 ps

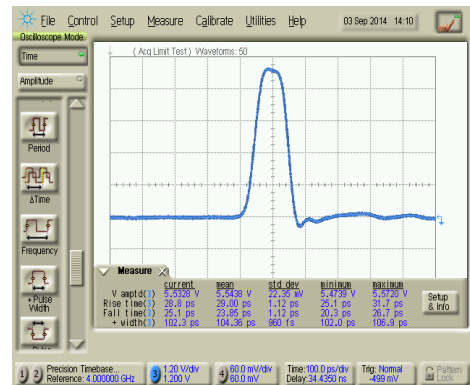

Output response: Pulse amplitude = 5.5 V_{pp}, Rise time = 29 ps

Short frequency repetition rate with medium pulse width: PW = 5 ns, PRF = 10 kHz

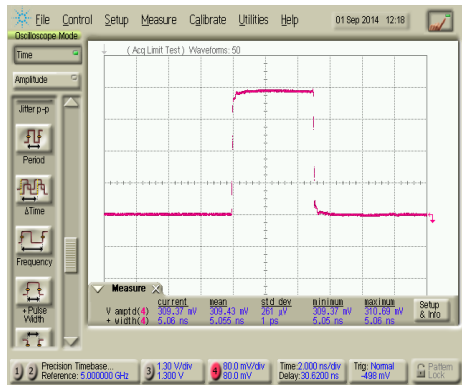

Input signal: Pulse amplitude = 0.31 mV_{pp}, Rise time = 16 ps

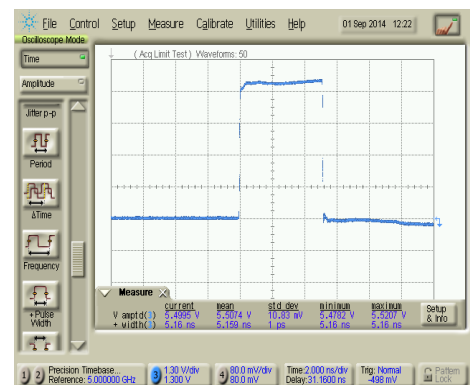

Output response: Pulse amplitude = 5.5 V_{pp}, Rise time = 24 ps

Short frequency repetition rate with long pulse width: PW = 200 ps, PRF = 20 MHz

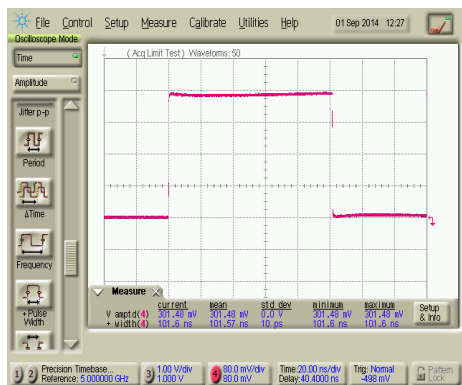

Input signal: Pulse amplitude = 0.37 mV_{pp}, Rise time = 16 ps

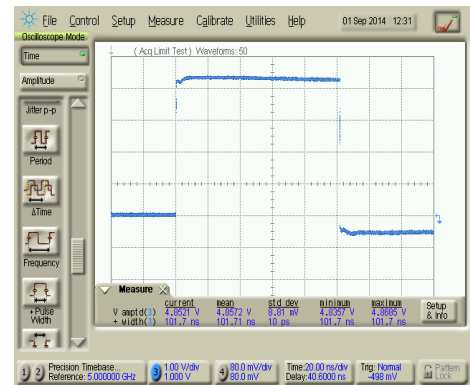

Output response: Pulse amplitude = 4.8 V_{pp}, Rise time = 24 ps

Electrical Schematic Diagram

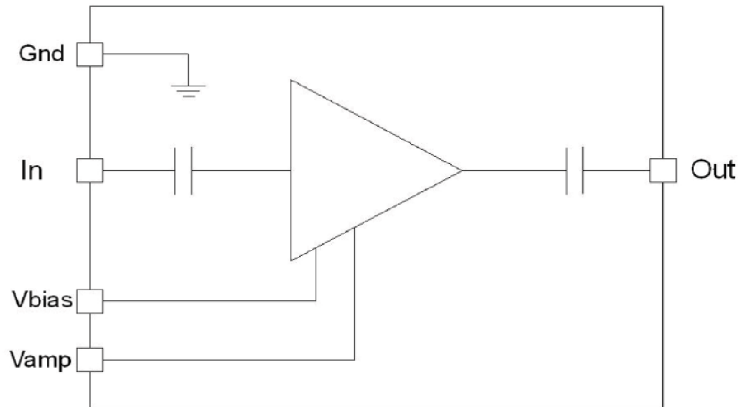

Mechanical Diagram and Pinout

All measurements in mm

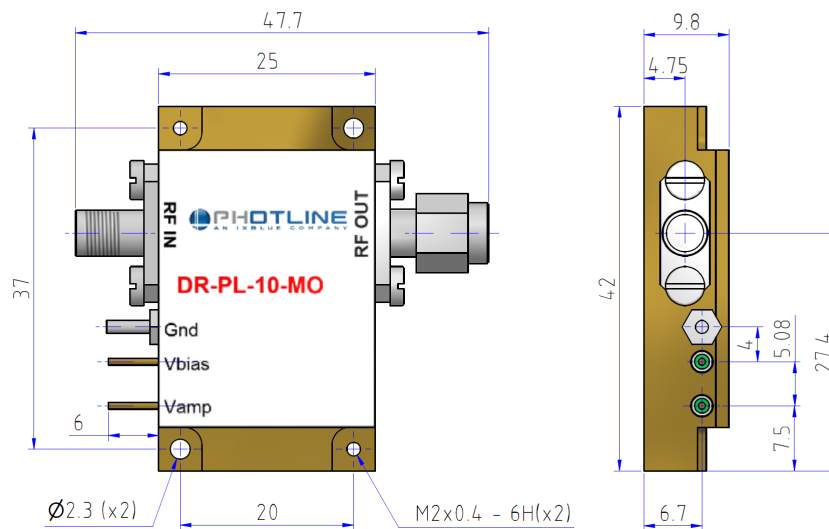

The heatsinking of the module is necessary. It's user responsibility to use an adequate heatsink. Refer to page 6 for iXBlue recommended heatsink.

PIN	Function	Operational Notes
IN	RF In	SMA-connector female
OUT	RF Out	SMA-connector male
V_{bias}	Power supply voltage	Set at typical operating specification
V_{amp}	Output voltage amplitude adjustment	Adjust for gain control tuning

Mechanical Diagram And Pinout With HS-HO1 Heatsink

All measurements in mm

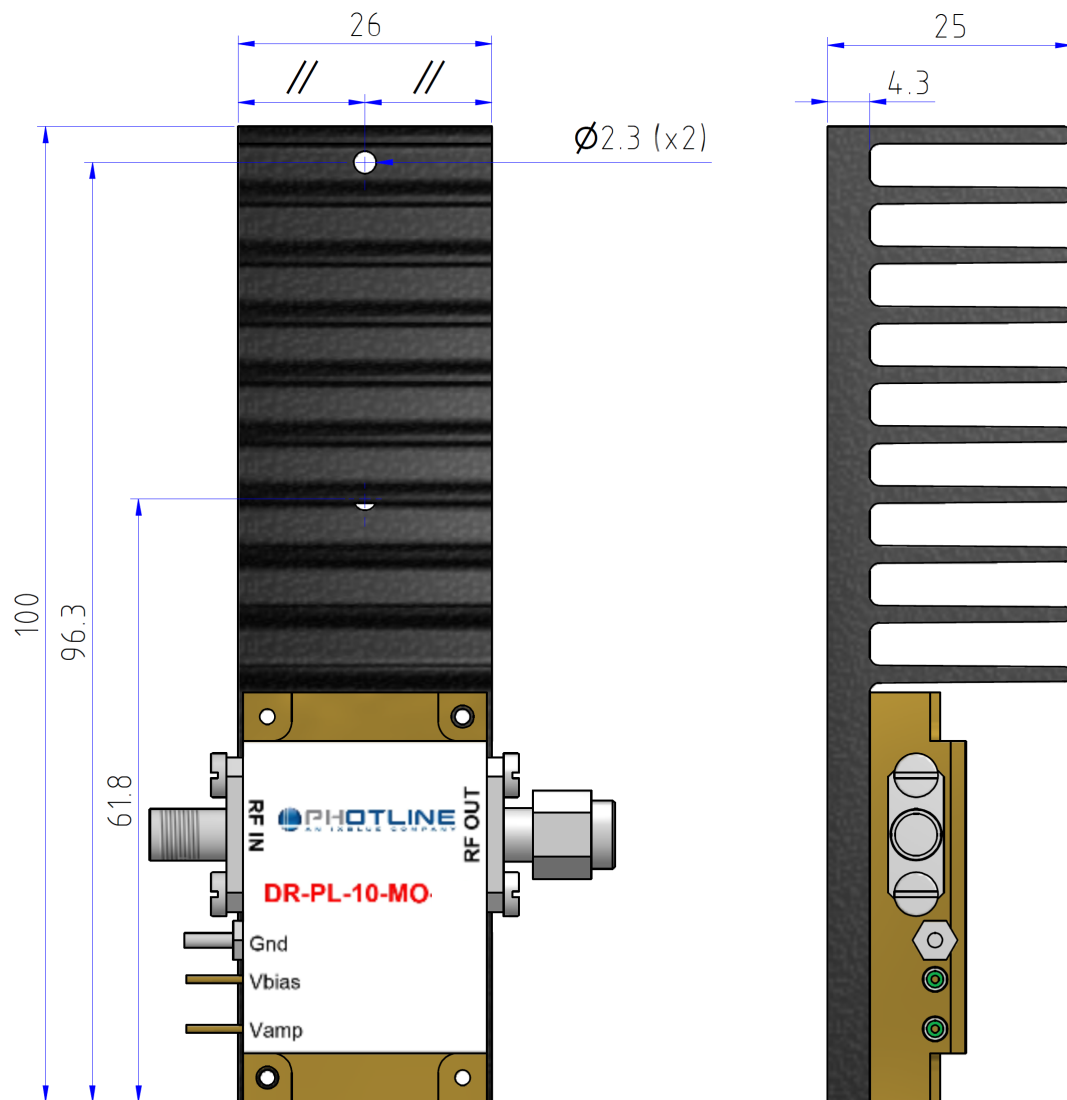

About us

iXBlue Photonics includes iXBlue iX Fiber brand that produces specialty optical fibers and Bragg gratings based fiber optics components and iXBlue Photline brand that provides optical modulation solutions based on the company lithium niobate (LiNbO_3) modulators and RF electronic modules.

iXBlue Photonics serves a wide range of industries: sensing and instruments, defense, telecommunications, space and fiber lasers as well as research laboratories all over the world.

3, rue Sophie Germain
25 000 Besançon - FRANCE
Tel. : +33 (0) 381 853 180 - Fax : +33 (0) 381 811 557

iXblue reserves the right to change, at any time and without notice, the specifications, design, function or form of its products described herein. All statements, specification, technical information related to the products herein are given in good faith and based upon information believed to be reliable and accurate at the moment of printing. However the accuracy and completeness thereof is not guaranteed. No liability is assumed for any inaccuracies and as a result of use of the products. The user must validate all parameters for each application before use and he assumes all risks in connection with the use of the products