

High Power Single-Frequency MOPAs (Master Oscillator Power Amplifiers)

Innovative Photonic Solutions introduces our Master Oscillator Power Amplifier (MOPA) that offers single-frequency and high power output. We take our proprietary wavelength stabilization technique a step further and amplify the very stable narrow linewidth output allowing our customers to have the best of both worlds.

We offer an internally PM fiber coupled MOPA with >300 mW single-frequency output power. Unlike other MOPAs that utilize external fiber alignment fixtures and require alignment each time environmental changes occur, IPS's MOPA is permanently affixed and needs no adjustment. For users that need open beam output, we offer an open beam MOPA with >500 mW single frequency output. Both versions of our MOPA are power adjustable and come fully "turn-key" in UL/CE and IEC certified modules with high performance laser drive and temperature controls and all safety features.

With high power and single-frequency, IPS's MOPAs are ideal for Raman Imaging & Microscopy, laser trapping & cooling, and applications that require a highly coherent light source like Speckle Imaging.

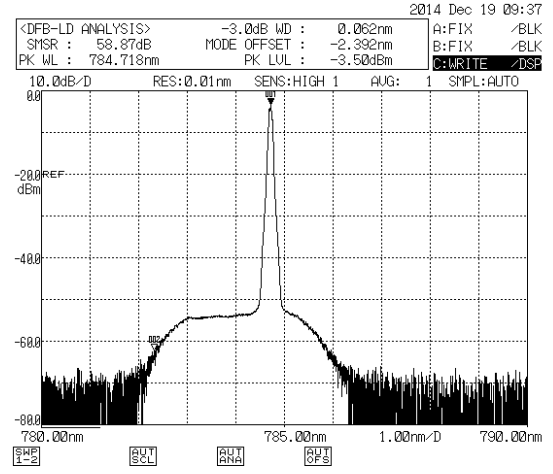

Typical 785 nm Stabilized Laser Spectrum

Standard Wavelengths

- 760 nm
- 780 nm
- 785 nm

Additional wavelengths available upon request



Single-Frequency Internally PM Fiber Coupled MOPA

- Wavelength Stabilized Spectrum
- > 300 mW PM Fiber Coupled output power
- TEM₀₀ with M²< 1.05
- UL/CE and IEC Certified
- Turn-Key Operation
- User adjustable output power
- Narrow Spectral Linewidth
- >40 dB SMSR Typical



Single-Frequency Open Beam MOPA

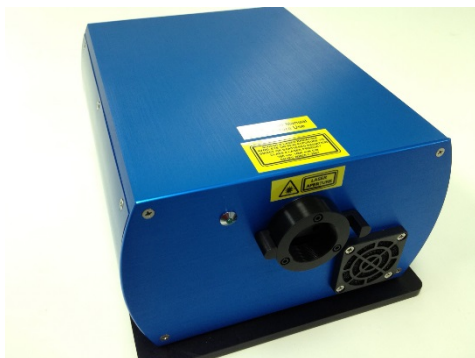

- Wavelength Stabilized Spectrum
- Circularized, astigmatism-free beam
- > 500 mW Open Beam Output
- 1W Open Beam Output upon request
- UL/CE and IEC Certified
- Turn-Key Operation
- User adjustable output power from 0 to 100%
- Narrow Spectral Linewidth
- >40 dB SMSR Typical
- >50 dB SMSR with laser line filter

PM Fiber Coupled Single-Frequency MOPA

The Innovative Photonic Solutions (IPS) Master Oscillator Power Amplifier (MOPA) provides a powerful and extremely stable wavelength stabilized laser source that is ideal for scientific applications including Raman Spectroscopy, Raman microscopy and imaging, and illumination.

IPS's fiber coupled MOPA is internally PM fiber coupled which provides TEM₀₀ output with M² < 1.05 and >300 mW output power.

Wavelength (nm)	Min. Power (mW)	Part Number
760	300	I0760SM0300PA-MOPA
780		I0780SM0300PA-MOPA
785		I0785SM0300PA-MOPA

Physical Specifications

Optical Fiber	Polarization Maintaining (PM), Panda Type
Connector	FC/APC
Module Dimensions	9.48 x 6.94 x 4.14 inches
Module weight	60 ounces
Case Material	Anodized Aluminum
Operating Temperature	10 to 35 degrees C
Environment	0-80% Humidity, non condensing
Storage Temperature	-10 to + 55 degrees C

Operational Notes

1. Do not retro-reflect beam! This can cause Catastrophic Optical Damage (COD) and is not covered under warranty.
2. Knob on front adjusts power by adjusting drive current. LED readout is in amperes.
3. See Operation Manual for full operating and safety instructions. This document is meant to offer a product overview.

General Optical Specifications

Wavelength Tolerance	+/- 0.5 nm
Spectral Linewidth ($\Delta\lambda$)	< 100 MHz typical
SMSR	35 -45 dB
Output Power Stability	< 3% short term (over seconds) < 10% typical long term
Output Power Adjustability	zero to full power
Beam Diameter	~ 4um at exit of fiber
Fiber Type	Corning PM850, Panda-style PM fiber, NA ~0.1
Peak Wavelength Drift	+/- 0.07 nm
Modulation Rate	10 kHz
Warm-up time	10 seconds from cold start
	1.5 seconds from warm start

Electrical Requirements

Input Power	100 – 240 VAC, 50 – 60 Hz, 0.4 A
Fuse Rating	250 V, 3.14 A, Slow Blow, 5 mm x 20 mm, 2 each

Mechanical Specifications – PM Fiber Coupled MOPA



Front View

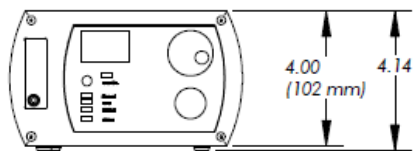

Side View

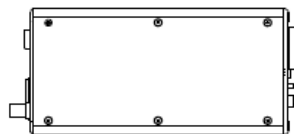

Back

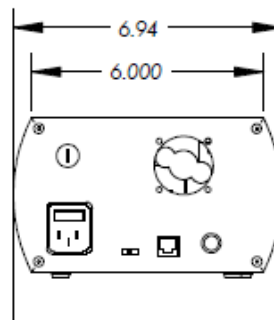

Bottom View

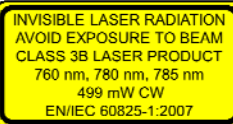
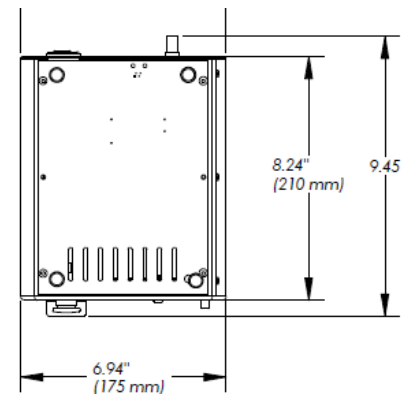

Open Beam Single-Frequency MOPA

The Innovative Photonic Solutions (IPS) Master Oscillator Power Amplifier (MOPA) provides a powerful and extremely stable wavelength stabilized laser source that is ideal for scientific applications including Raman Spectroscopy and Illumination. The Open beam MOPA offers TEM₀₀ output with M² < 1.7 (in center lobe) and >500 mW output power.

Up to 1W available upon request.

Wavelength (nm)	Min. Power (mW)	Part Number
760	500*	I0760SR0500B-MOPA
780		I0780SR0500B-MOPA
785		I0785SR0500B-MOPA

Physical Specifications	
Module Dimensions	229 x 175 x 113 mm
Module weight	100 ounces
Case Material	Anodized Aluminum
Operating Temperature	10 to 35 degrees C
Environment	0-80% Humidity, non condensing
Storage Temperature	-10 to + 55 degrees C

- | Operational Notes | |
|---|--|
| 1. Do not retro-reflect beam! This can cause Catastrophic Optical Damage (COD) and is not covered under warranty. | |
| 2. Knob on rear panel adjusts power by adjusting drive current. | |
| 3. See Operation Manual for full operating and safety instructions. | |
| This document is meant to offer a product overview. | |

General Optical Specifications	
Wavelength Tolerance	+/- 0.5 nm
Spectral Linewidth ($\Delta\lambda$)	< 100 MHz typical
SMSR	35 -45 dB
Output Power Stability	< 3% short term (over seconds) < 10% long term
Output Power Adjustability	zero to full power
Beam Diameter	~0.5 mm at exit
Divergence	~ 3 mrad
Peak Wavelength Drift	+/- 0.07nm
Modulation	10 kHz
Warm-up time	10 seconds from cold start
	1.5 seconds from warm start

Electrical Requirements	
Input Power	100 – 240 VAC, 50 – 60 Hz, 0.4 A
Fuse Rating	250 V, 3.14 A, Slow Blow, 5 mm x20 mm, 2 each

Mechanical Specifications – Open Beam MOPA

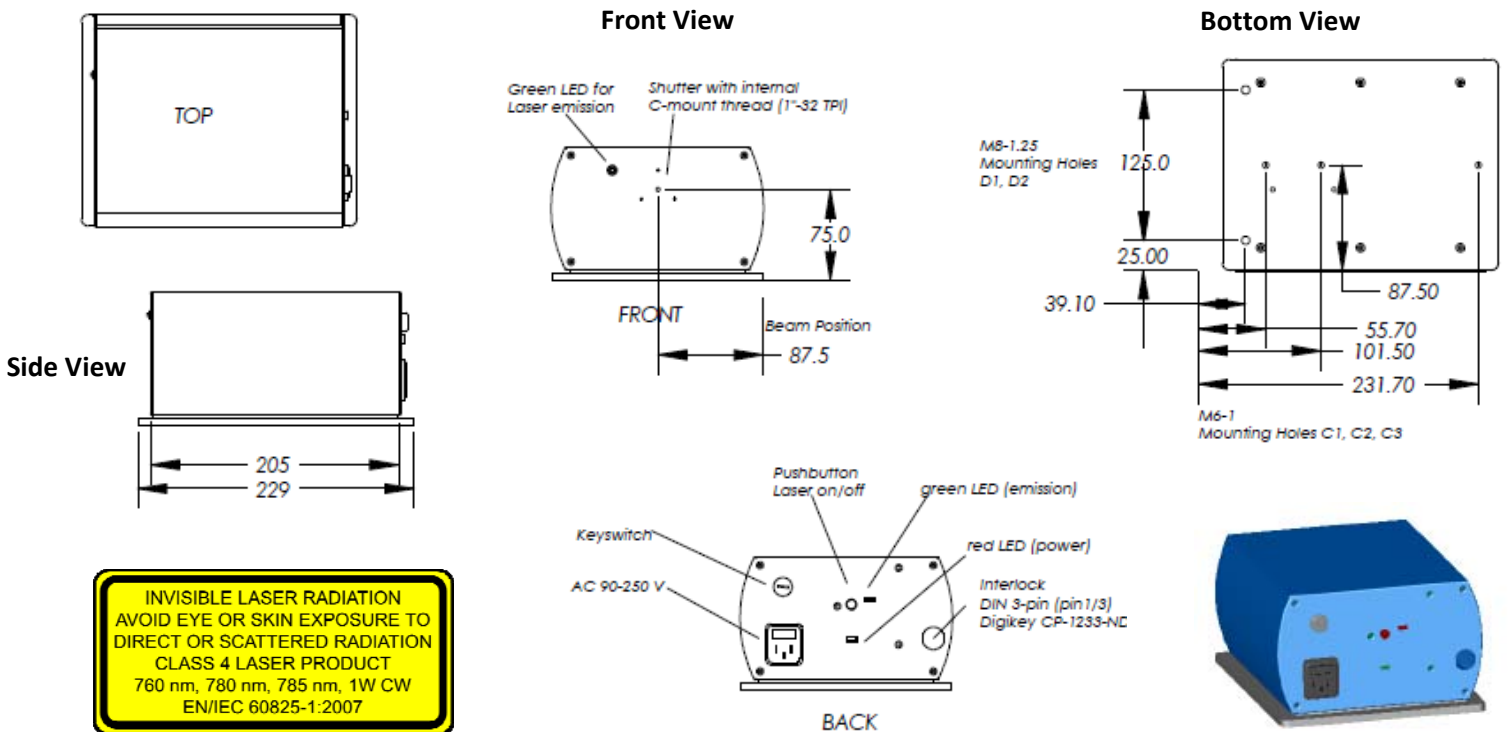

INVISIBLE LASER RADIATION
 AVOID EYE OR SKIN EXPOSURE TO
 DIRECT OR SCATTERED RADIATION
 CLASS 4 LASER PRODUCT
 760 nm, 780 nm, 785 nm, 1W CW
 EN/IEC 60825-1:2007

* Up to 1W open beam output power available upon request