

APR-10-MC



DEVICE

10 GHz High Gain Avalanche Photoreceiver Module

OVERVIEW

The Optilab APR-10-MC is a 10 GHz bandwidth receiver module consisting of an avalanche photodiode and a limiting amplifier. This compact, cost-effective receiver module can provide users with status monitoring through a USB interface. The APR-10-MC requires a single 12 Volt DC power supply for operation. Contact Optilab for more information, (602)343-1496.

FEATURES

- Conversion gain of 12,000 V/W
- Useful O/E bandwidth up to 10 GHz
- Status monitoring: RS-232
- AC-coupled output
- Single 12 V power supply

USE IN

- Wideband RF Transmission over Fiber
- Broadband delay-line and signal processing
- Phased and interferometric array antenna
- High speed LIDAR Receiver
- High gain O/E converter

FUNCTIONAL DIAGRAM

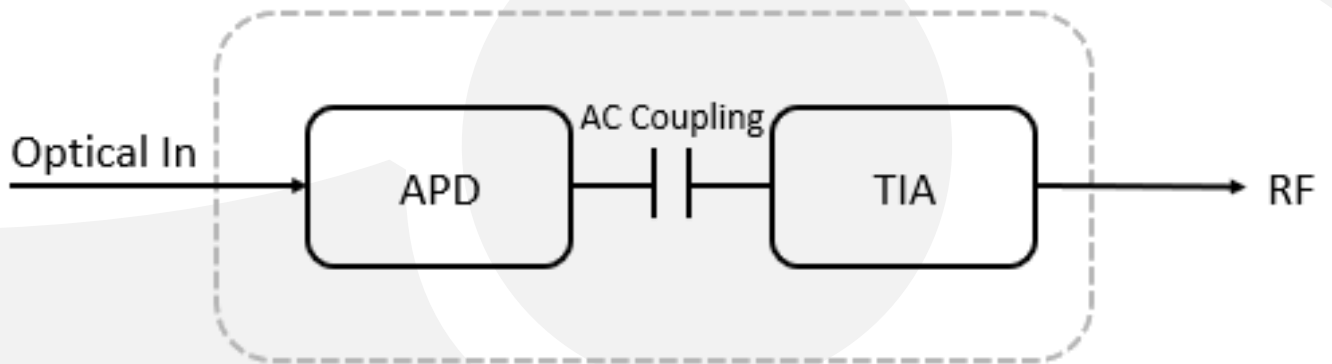

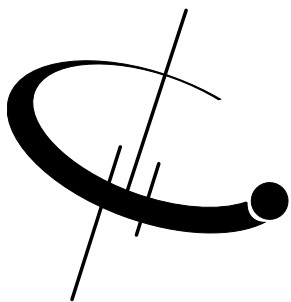

APR-10-MC

SPECIFICATIONS

GENERAL

Photodiode Wavelength Range	1300 nm to 1610 nm
Operational Bandwidth	10 GHz
Small Signal Diff. Conversion Gain	Over 12,000 V/W @ 1550 nm
Gain Ripple	± 1.5 dB
Responsivity	0.85 A/W @ 1310 nm typ., 0.90 A/W @ 1550 nm typ., 0.80 A/W @ 1610 nm typ.
Minimum Optical Input	-26 dBm
S21 3 dB Bandwidth	7.5 GHz typ.
S22 Characteristics	-12 dB from 130 MHz to 6 GHz; -7 dB from 130 MHz to 8 GHz
Optical Return Loss	27 dB min.
Output Coupling	AC Coupled
Maximum Overload	-5 dBm typ.
Group Delay Deviation	50 ps

MECHANICAL

Operating Temperature	-5°C to +75°C
Storage Temperature	-40°C to +85°C
Power Supply Requirements	12V
Optical Connector	FC/APC
RF Output Connector	SMA Connector Female, 50Ω
Local Alarm LED	Optical Input Power
Remote Alarm	OLED Display
Dimensions	280mm x 90mm x 340mm
Housing	Anodized Aluminum



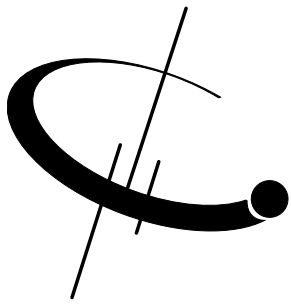

APR-10-MC

MECHANICAL DRAWING

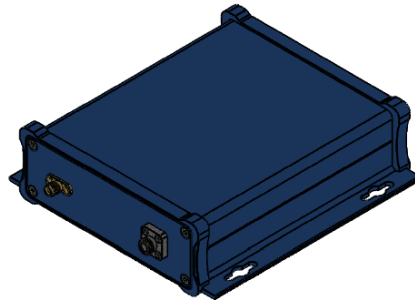
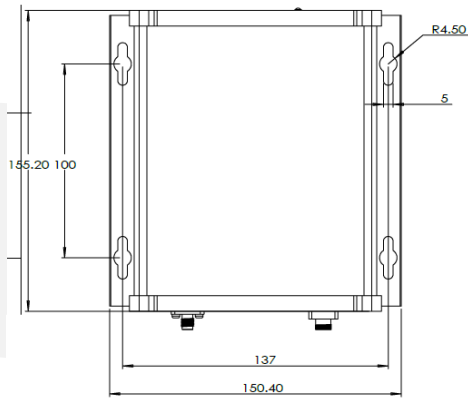
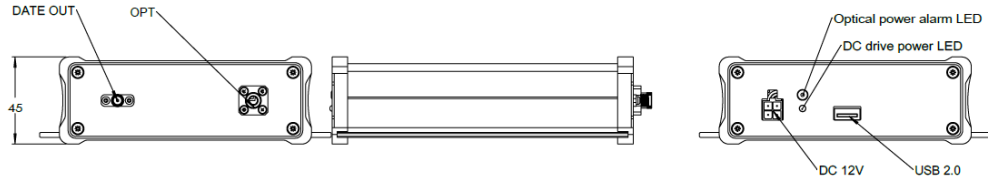

S21 TEST DATA

