

# DFB-1550-PM

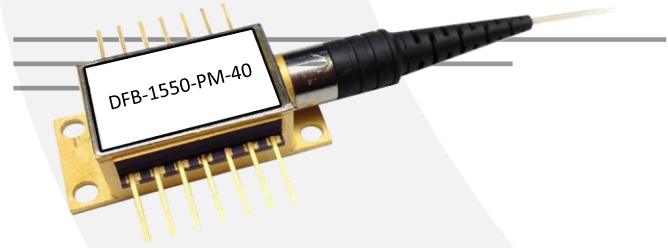

## DEVICE

# 1550 nm DFB Laser Diode, PM Output, up to 40 mW

## OVERVIEW

The Optilab DFB-1550-PM-40 is a Distributed FeedBack Laser designed for Continuous Wave (C.W) operation. It is mostly utilized in combination with an external optical modulator, such as a Mach-Zehnder Interferometer (MZI) modulator. The MQW DFB laser features up to 40 mW of output optical power, high side mode suppression ratio, low RIN noise, and a narrow linewidth. The DFB-1550-PM-40 is housed in an industry standard 14-pin butterfly package, with a built-in thermoelectric cooler, thermistor, a back-facet monitor photodiode for conventional power monitoring, and an optional second photodiode for wavelength reference monitoring. Available in a wide variety of C-band wavelengths, the DFB-1550-PM-40 can be temperature tuned to ITU frequencies to allow for Dense Wavelength Division Multiplexing (DWDM) applications.

## FEATURES

- Polarization maintaining output
- Up to 40 mW output power
- Low RIN noise, -145 dB/Hz max.
- Wavelengths Range to select: from 1528 nm to 1562 nm
- Built in TEC, Thermistor & Monitor PD

## USE IN

- Dense Wavelength Division Multiplex (DWDM)
- RF over Fiber (RToF)
- Hybrid Fiber-Coaxial (HFC)
- General laboratory and research use
- CW Laser source

## FUNCTIONAL DIAGRAM

- |                     |                         |
|---------------------|-------------------------|
| 1 Thermistor        | 8 Case Ground           |
| 2 Thermistor        | 9 Case Ground           |
| 3 Laser DC Bias (-) | 10 Not Connected        |
| 4 Monitor Anode     | 11 Laser Ground         |
| 5 Monitor Cathode   | 12 Laser Modulation (-) |
| 6 TEC (+)           | 13 Case Ground          |
| 7 TEC (-)           | 14 Not Connected        |

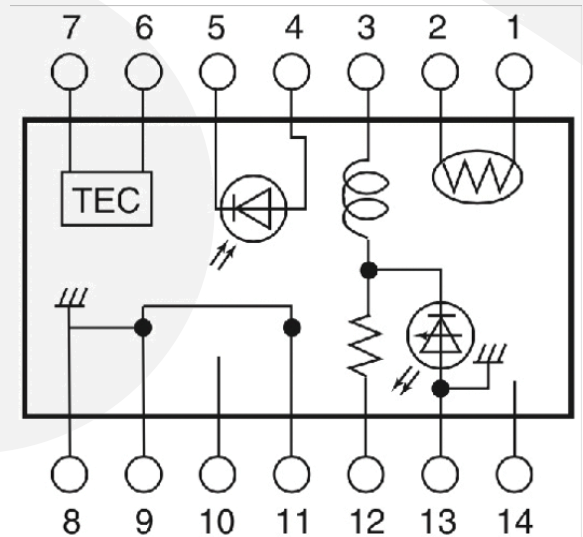

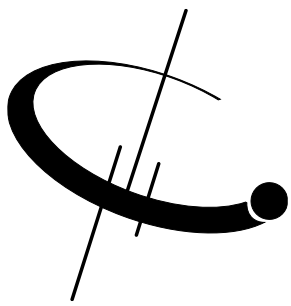

# DFB-1550-PM-40

## SPECIFICATIONS

Wavelength Range	1528nm-1562nm
Wavelength Accuracy	± 2 nm
Wavelength Tuning	± 1.5 nm
Optical Output Power	20, 30, 40 mW
Operating Current	300 mA max. @ CW
Forward Voltage	2.5 V typ.
Series Resistance	25 Ω typ.
Threshold Current	25 mA typ.
Monitor Current	0.10 mA min., 1.0 mA max.
Photodiode Dark Current	2 nA typ., 100 nA max.
Side Mode Suppression	40 dB min.
Linewidth	3 MHz max
Optical Isolation	35 dB typ.
Relative Intensity Noise	-160 dB/Hz max.
Polarization Extinction Ratio	20 dB typ.

## GENERAL

## MECHANICAL

Operating Temperature	-10°C to +60 °C
Storage Temperature	-40°C to +70 °C
Operating Humidity	95% @ < 30 °C
Optical Fiber Type	PANDA PM
Optical Connector	FC/APC, other available

## TEC AND THERMISTOR CHARACTERISTICS

TEC Current	1.0 A max.
TEC Voltage	2.4V max.
TEC Resistance	2.4 Ω typ.
Thermistor Resistance	7.7 k Ω min., 12.6 k Ω max.
Thermistor B Constant	3,270 K min., 3,450 K typ., 3,630 K max.

## ABSOLUTE MAXIMUM RATING

Reverse Voltage	2 V
Operating Current	400 mA
PD Reverse Voltage	20 V
PD Forward Current	10 mA
TEC Voltage	4 V
TEC Current	4 A





# DFB-1550-PM-40

TYPICAL EXAMPLE L-I CURVE FOR DFB-1550-PM SERIES

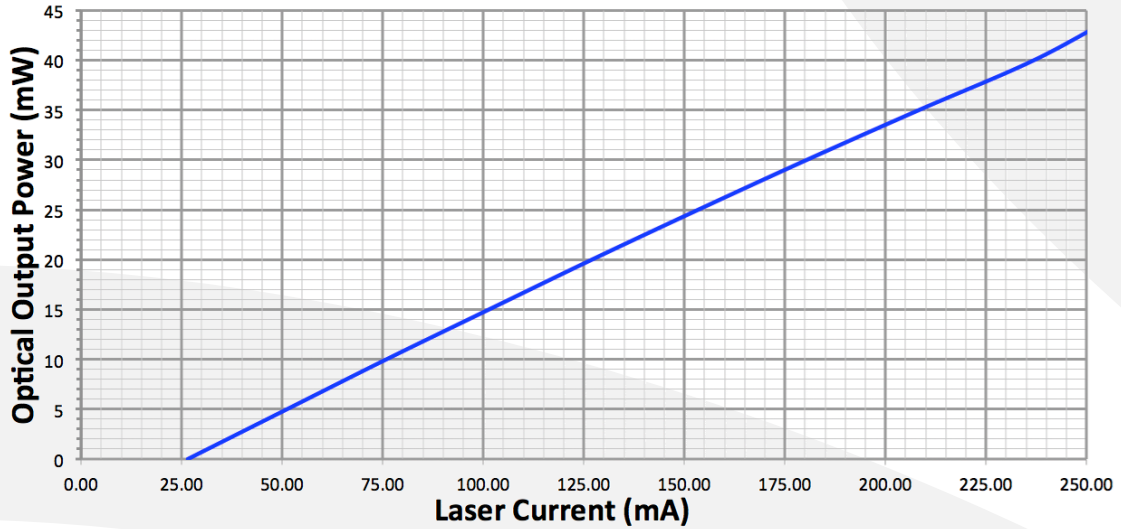

MECHANICAL DRAWING

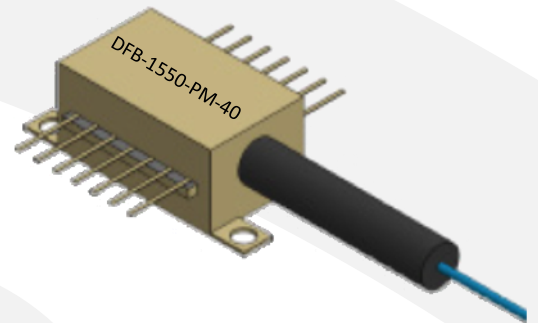
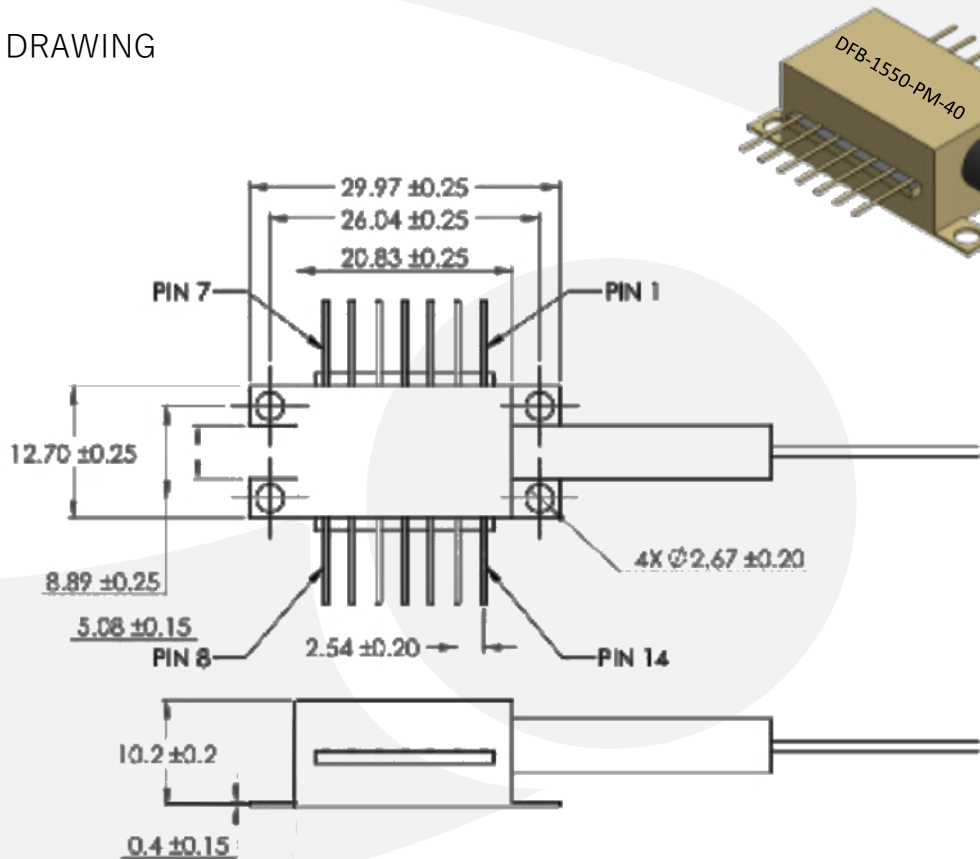

Unit: mm



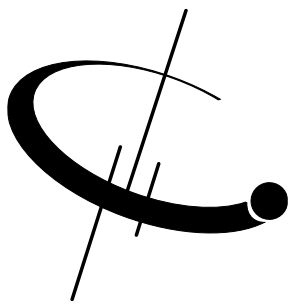

# DFB-1550-PM-40

## AVAILABLE DFB-XXXX-PM WAVELENGTHS

Wavelength Selection	
1528 nm	1546 nm
1530 nm	1548 nm
1532 nm	1550 nm
1534 nm	1552 nm
1536 nm	1554 nm
1538 nm	1556 nm
1540 nm	1558 nm
1542 nm	1560 nm
1544 nm	1562 nm

## OPTIONS

### DFB-XXXX-PM-YY

**XXXX:** Wavelength in nm

**YY:** Output Power in mW  
20  
30  
40

## AVAILABLE ACCESSORIES

### UNIVERSAL LASER DIODE CONTROLLER (ULDC)



ULDC is a fully integrated laser diode controller with precise current and temperature setting. With a Zero Insertion Force (ZIF) adaptor, ULDC can be used with all 14 pin laser diodes.

### DFB LASER SOURCE MODULE, POLARIZATION MAINTAINING (DFB-PM-M)

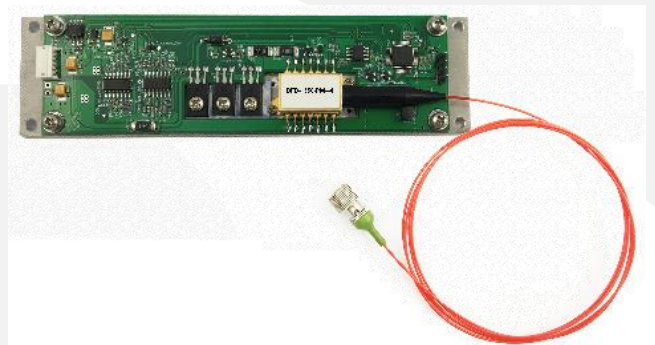

DFB-1550-PM can be ordered as DFB- PM-M, which allows DFB laser's operating temperature and output power precisely controlled to ensure constant wavelength and power stability. It can be used for module level integration system.

