

# FML-15-M



## Femtosecond Mode-Locked Laser, Module

The Optilab FML-15-M Femtosecond Mode-Locked Laser (FML) Module utilizes a proprietary Saturable Absorber (SA) for passive mode locking. It delivers femtosecond pulses with an excellent power stability and reliability. Designed with no moving parts, and requiring no polarization controller, the compact FML-15-M is built with highly qualified photonics components to provide operation life of 10+ year. The pulse width is factory selectable from 200 fs and up, with near transform-limited pulse shape and a better than 20 dB pedestal, and the pulse repetition rate can be specified from 10 to 50 MHz with either a polarization maintaining (PM) or single mode (SM) fiber output. Contact Optilab for more information.

### Features

- All fiber base requires no adjustment
- Pulse width from 200 fs
- 30 mW output typ.
- 1540 to 1560 nm peak wavelength
- Near transform-limited output
- Peak Pulse Power: 4 kW typ.
- Pulse Energy: 1 nJ
- Compact, low power, reliable
- PM version available

### Applications

- Super continuum generation
- Telecom components characterization
- Optical high speed sampling
- Terahertz radiation
- Optical switching
- Materials characterization
- Optical metrology

### Functional Diagram

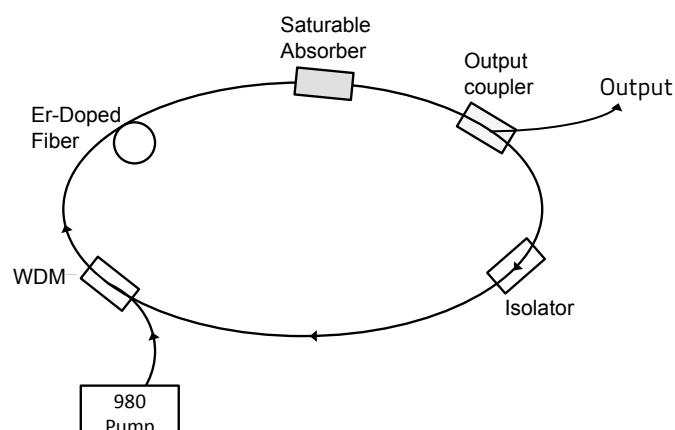

# Femtosecond Mode-Locked Laser, Module

## OPTIONS

**FML-15-M-XX-YY**

XX PM Output

YY TG: Trigger out

## TECHNICAL INFO

For technical info and support:

[sales@optilab.com](mailto:sales@optilab.com)

[www.optilab.com](http://www.optilab.com)

## WEB ORDER

To order, please click below.



General Specifications	
Output power	30 mW typ.
Peak wavelength	1540 nm - 1560 nm , other available
3 dB Spectral bandwidth	20 nm - 35 nm, typ.
Pulse duration	200 fs and up
Pulse repetition rate	10 MHz - 50 MHz
Peak Pulse Power	4 kW typ.
Pulse Energy	1 nJ
Polarization Extinction Ratio	20 dB for PM version
Trigger Output (Optional)	Pulse converted to electrical output
Mechanical Specifications	
Operating Temperature	+5° C to +50° C
Storage Temperature	-55° C to +85° C
Optical Connector	FC/APC, other optional
Electrical Connector	DB-25
Remote Control	RS-232 Interface
Dimensions	250 mm x 135 mm x 40 mm
Accessories Included	+/- 5V DC power supply

## Optilab Advantage

- Innovation
- Performance
- Quality
- Customization
- Warranty

## Mechanical Drawing

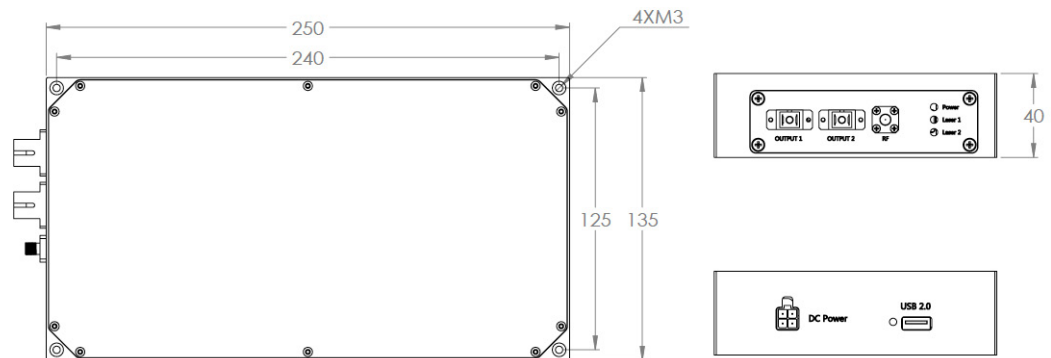

Unit: mm

# Femtosecond Mode-Locked Laser, Module

## Sample Measurement Results

Parameter	Unit	Main Output	Tap Output
Peak Wavelength	nm	1575	1567
Linewidth	nm	35	29
Average Power	mW	28.18	1.62
Repetition Rate	MHz	30.27	
Pulse Width*	fs	235	211
Pulse Energy	nJ	0.93	0.05
Peak Power	kW	3.96	0.25

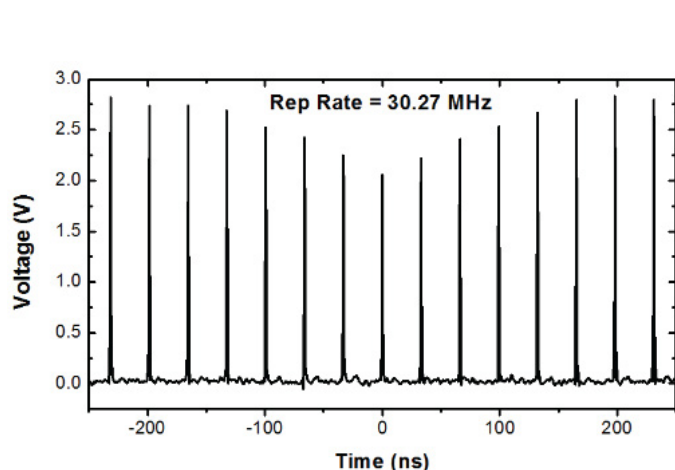

Figure 1: Repetition Rate Measurement

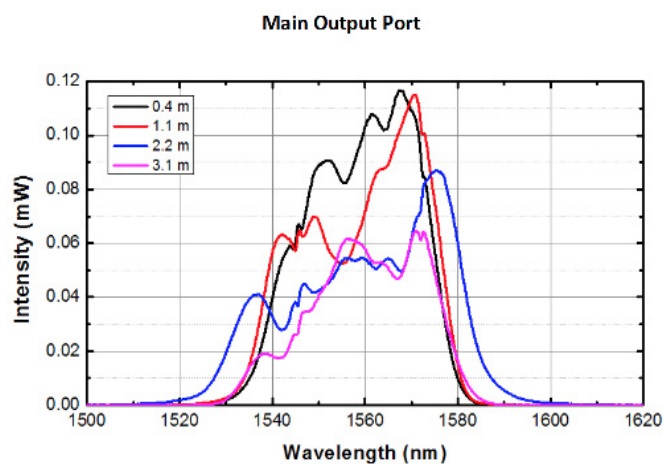

Figure 2: Main output spectrum measured at output coupling fiber of 0.36 m, 1.1 m, 2.2 m and 3.1 m length.

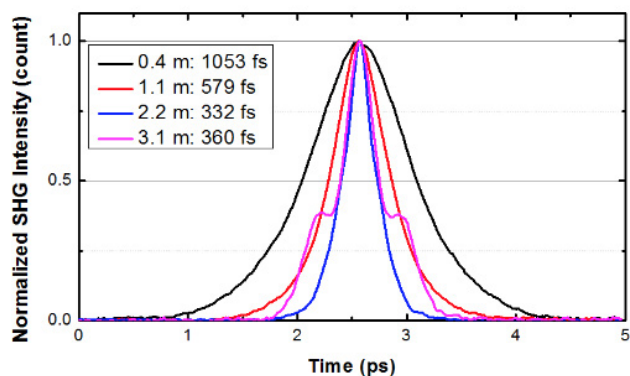

Figure 3: Autocorrelation measurement of main port output measured with four different output coupling fiber: 0.36 m, 1.1 m, 2.2 m and 3.1 m long, with FWHM at 1053, 579, 332 and 360 fs respectively.