

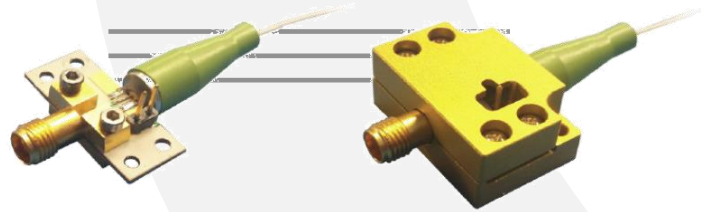

PD-23-MM



DEVICE

23 GHz Linear InGaAs PIN Photodetector, Multimode Fiber

OVERVIEW

The Optilab PD-23-MM is a highly linear, 23 GHz bandwidth InGaAs PIN photodetector that is ideal for use in O/E front-ends requiring wide band frequency response. The coplanar waveguide photodiode design optimizes speed and sensitivity for the 1260 nm through 1610 nm wavelength range and assures a 23 GHz frequency response necessary for digital and analog applications. The front-illuminated mesa-structured PIN design allows a high input power level of up to 20 mW. The PD-23-MM features 50/125 μ m fiber type, available in a standard 2-pin package with K-connector output for ease of assembly and can be ordered with or without the external protective housing. Contact Optilab for more information.

FEATURES

- Operating Temp. from -10°C to +50°C
- Useful Spectral Range 850-1650nm
- High Current Handling up to 35 mA
- Highly Linear to 30 mW+ input power
- 50/125 μ m multimode fiber input
- Wide bandwidth 60 KHz to 23 GHz
- Flat Frequency Response, +/- 1 dB

USE IN

- Front-End O/E Converter for Test Instruments
- Analog RF over Fiber
- LIDAR Measurements
- Coherent Lightwave Systems
- Optically Amplified Systems
- RZ and NRZ up to 23 Gb/s

ORDERING OPTIONS

PD-23-MM-x-yy

- | | | | |
|----------|-------------------------|-----------|----------------|
| x | A, No Housing (default) | yy | AC, AC coupled |
| | C, External Housing | | DC, DC coupled |

FUNCTIONAL DIAGRAM

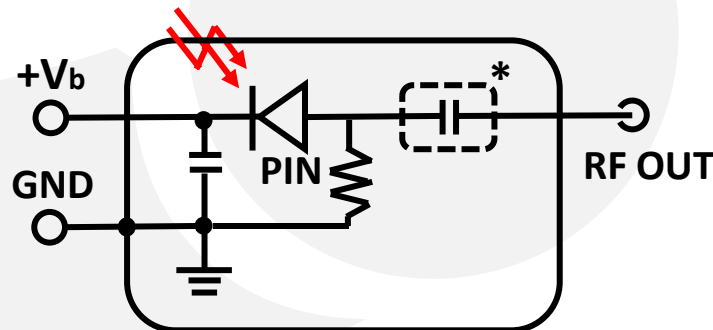

*Optional DC Block for AC Coupled Version



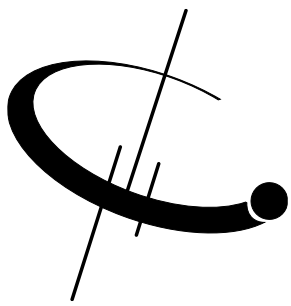

PD-23-MM

SPECIFICATIONS

GENERAL

Optimized Operating Wavelength	1260 nm to 1610 nm
Useful Operating Wavelength	850 nm to 1650 nm
Optical Input Level	30 mW max.
S21 3 dB Bandwidth	19 GHz min., 21 GHz typ.
S22 Characteristics	< -10 dB at 12 GHz typ.
Responsivity	0.85 A/W @ 1550 nm typ.
Dark Current @ 25°C, 5 V	10 nA typ., 100 nA max.
Optical Return Loss	-30 dB typ.
Optical PDL @ 1550 nm	0.05 dB max.
Bias Voltage	5 V typ.
Impedance	50 Ω
Coupling	AC-Coupled (DC Coupled optional)

MECHANICAL

Operating Temperature	-10 °C to +50 °C
Storage Temperature	-20 °C to +80 °C
Ripple over any 1 GHz	85%
Group Delay	5V, ± 1 V DC
2 nd Harmonics Distortion	2-pin module with SMA Female RF connector
3 rd Harmonics Distortion	30 mm x 20 mm x 14 mm
Fiber Connector	FC/APC
Optical Fiber	MMF 50/125 um with 90 mm Tube

ABSOLUTE MAXIMUM RATINGS

PIN Bias Voltage	+ 2.0 to +7 V
Forward Current	35 mA
Optical Input Power Damage Threshold	30 mW
Lead Soldering Temp (10 s)	250°C





PD-23-MM

S21 O/E RESPONSE

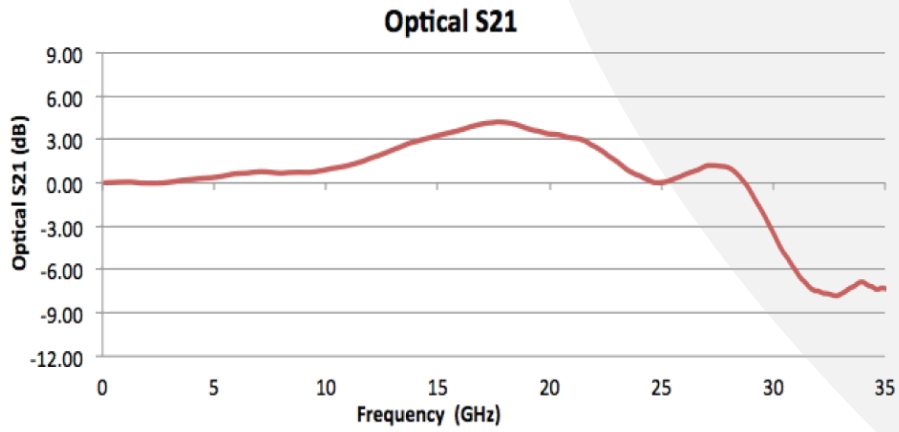

CSO, CTB LINEARITY MEASUREMENT

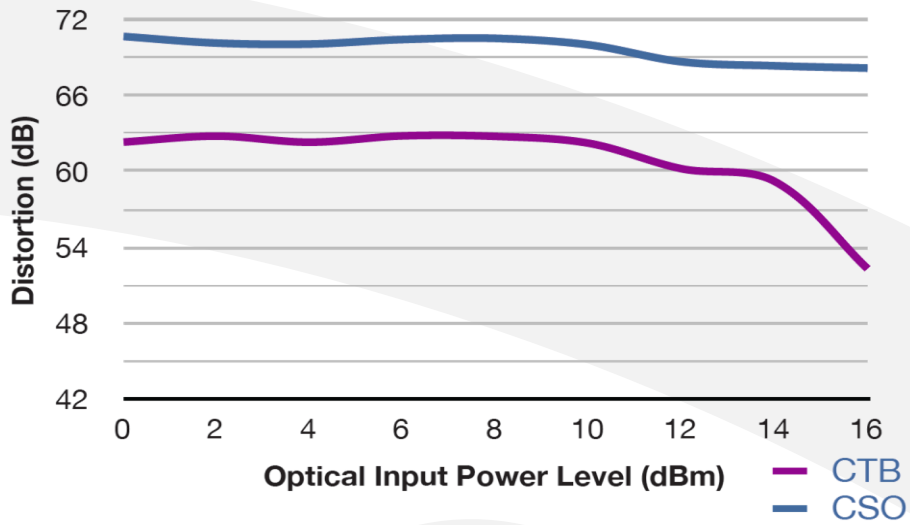

LINK LOSS

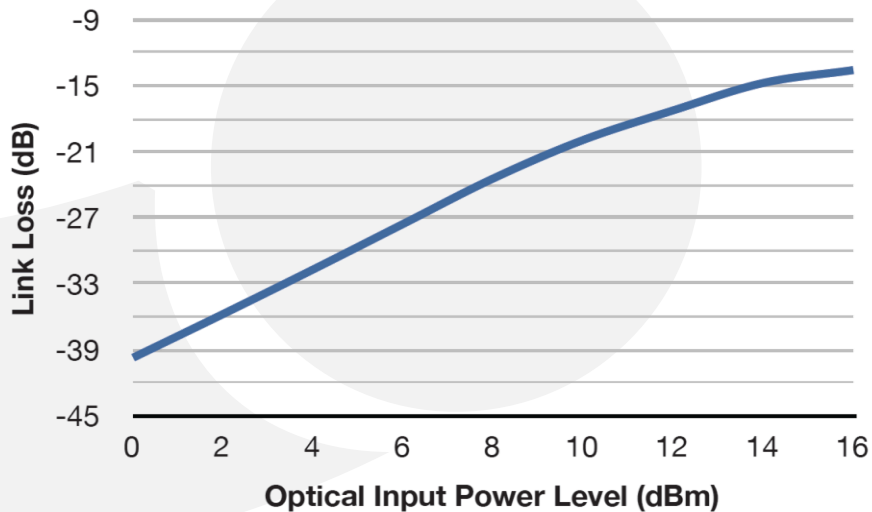

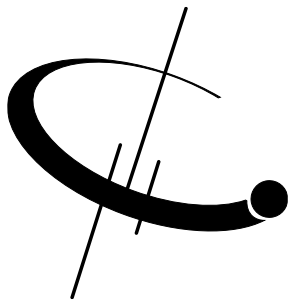

PD-23-MM

PD-23-MM-A MECHANICAL DRAWING

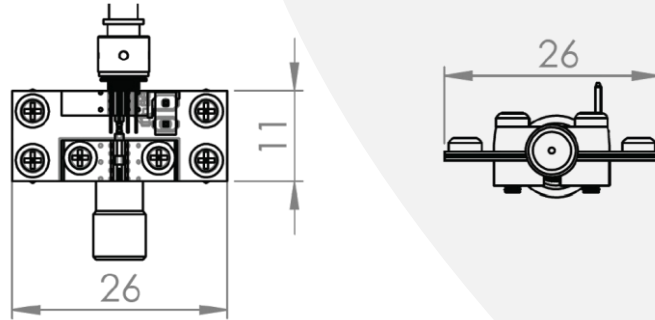

PD-23-MM-C MECHANICAL DRAWING W/ EXTERNAL HOUSING

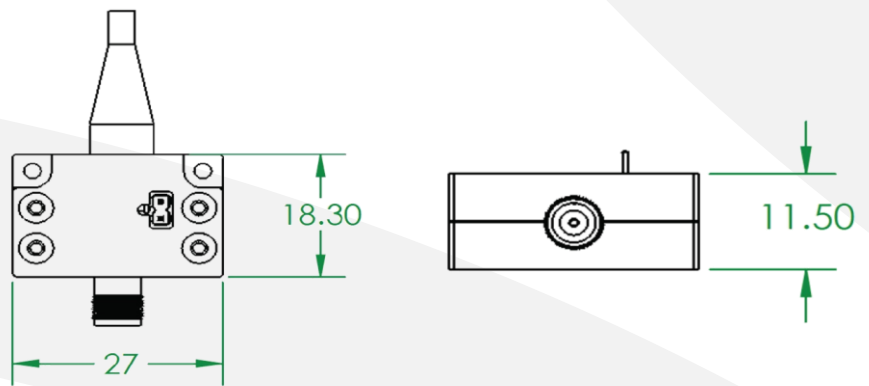

PD-23-MM-M MODULE HOUSING

In addition to the standard PCB and external housing options, Optilab offers a turn-key modular solution with a USB 2.0 interface, which can be operated with any standard PC platform device or with the provided AC/DC adapter. Contact Optilab for more information.

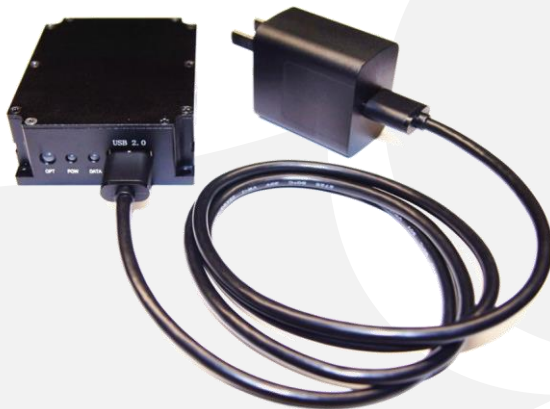

- All measurements are in Metric
- External housing if for Mechanical Protection Only
- Legacy housing information available upon request

