

SOA-1310-BP

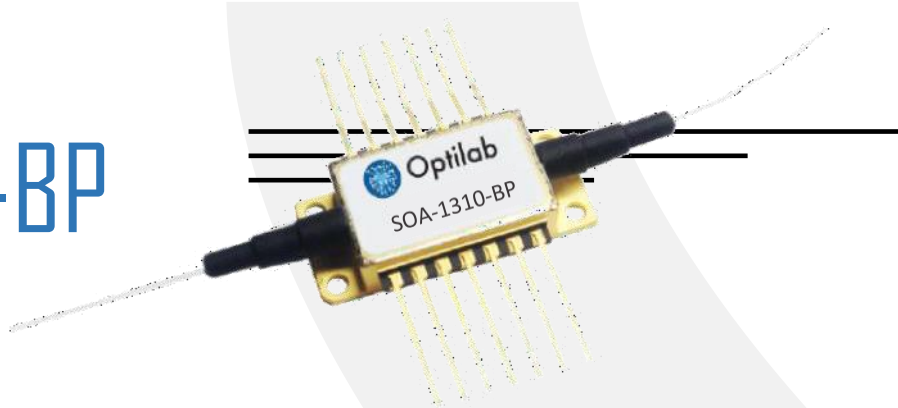

DEVICE

1310 nm Semiconductor Optical Amplifier, Butterfly Package

OVERVIEW

The Optilab SOA-1310-BP is a semiconductor optical amplifier with high fiber-to-fiber gain, designed to be used in general applications to increase optical launch power to compensate for loss of other optical devices, or as a broadband ASE source. For increased utility, the SOA-1310-BP can be ordered with either Single Mode (SM) or Polarization Maintaining (PM) fiber input and output ports. The Optilab SOA-1310-BP has an operational wavelength between 1250 nm and 1350 nm, with a peak gain of a typical 20 dB within that region. The 14-pin butterfly packaging is MSA compliant and laser-welded hermetically sealed, with a thermistor and thermo-electric cooler (TEC) for ensured reliability, stability and performance.

FEATURES

- 1250nm-1350nm operational wavelength
- High-fiber-to-fiber gain of 20 dB typ.
- Up to 14 dBm output
- Built in TEC
- 14 pin butterfly, hermetically sealed package
- PM Panda fiber input/output (optional)

USE IN

- Swept Fiber Laser
- Booster and in-line amplification
- General purpose test and measurement
- Optical network
- Fiber sensing

PIN-OUT DIAGRAM

1 TEC (+)	8 NC
2 Thermistor	9 NC
3 NC	10 LD Anode (+)
4 NC	11 LD Cathode (-)
5 Thermistor	12 NC
6 NC	13 NC
7 NC	14 TEC (-)

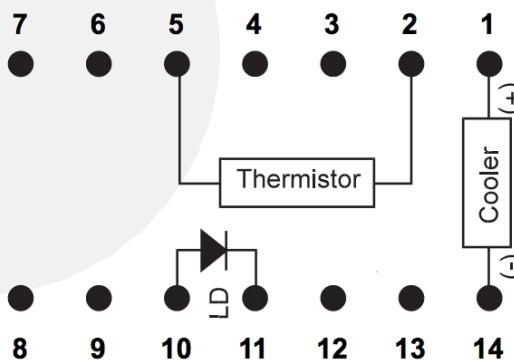

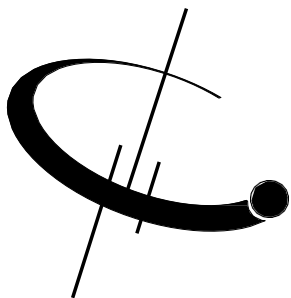

SOA-1310-BP

OPERATING SPECIFICATIONS

Operational Wavelength	1250 nm – 1350 nm
Peak Gain	19 dB min., 20 dB typ.
Gain Ripple	± 1 dB max.
Polarization Dependent Gain (PDG)	± 1 dB max.
Saturation Output Power	13 dBm typ.
Input Power	-25 ~ +5 dBm
Forward Voltage	2 V typ.
Operating Bias Current	350 mA type
Thermistor Resistance	10 kΩ typ. @ 25°C
Connectors	FC/APC, others optional

ABSOLUTE MAXIMUM RATINGS

Operating Temperature (Case)	-10°C to +70°C, TQ version available
Storage Temperature	-40°C to +85°C
Operating Humidity	0% to 85% Relative Humidity
Operating Bias Current	400 mA
Optical Amplifier Reverse Bias	2 V
Thermistor Current	10kΩ NTC
TEC Current	1.8 A
TEC Voltage	3.4 V

OPTIONS

SOA-1310-XX-BP

XX SM: Single Mode or PM: Polarization Maintaining



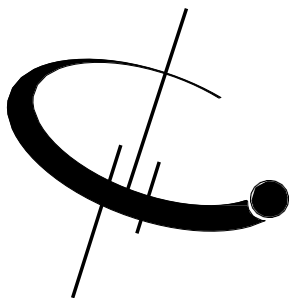

SOA-1310-BP

MECHANICAL DRAWING

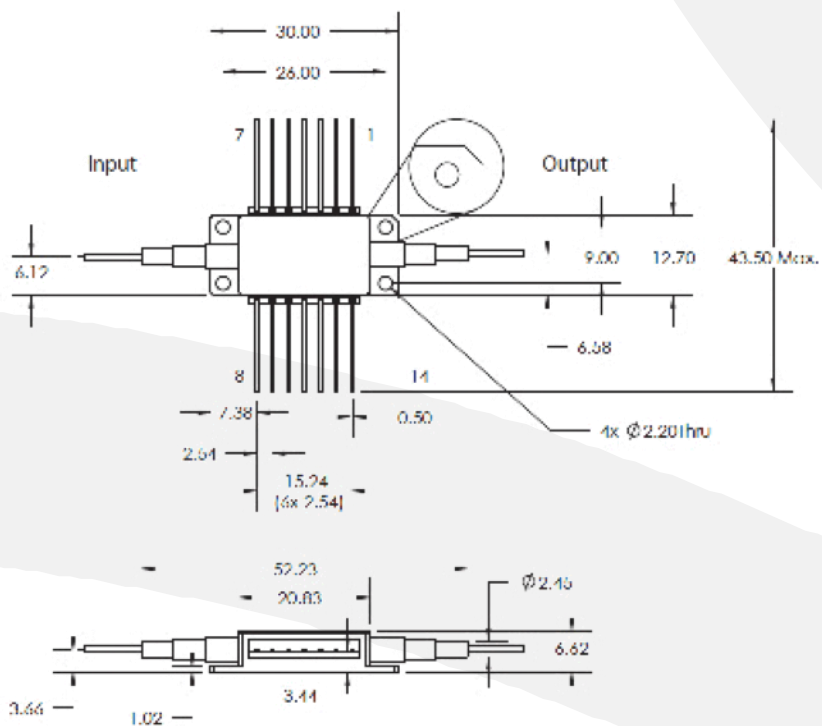

DETAILED SPECTRUM INFORMATION

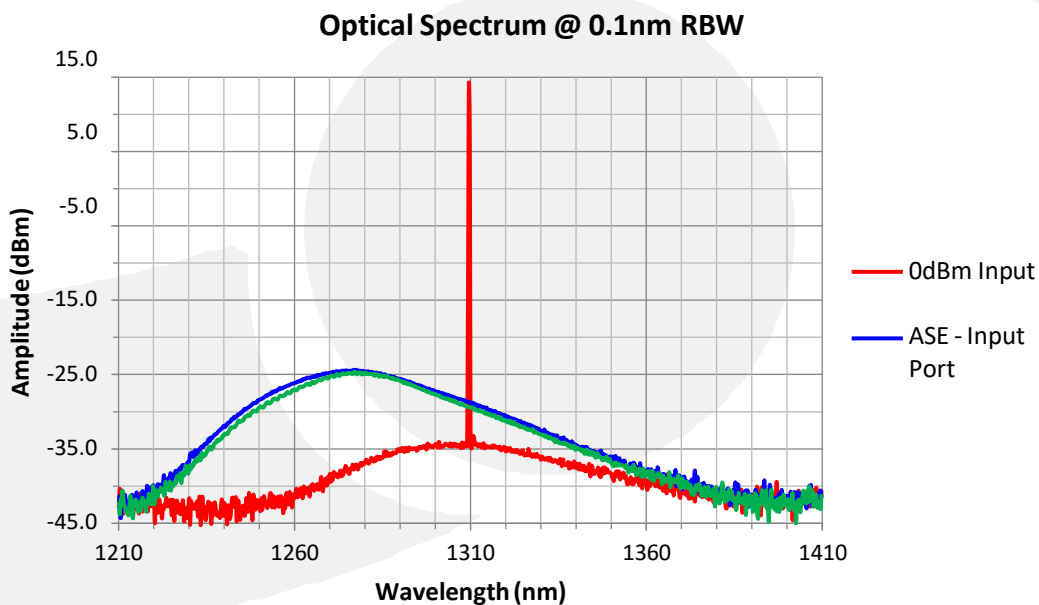

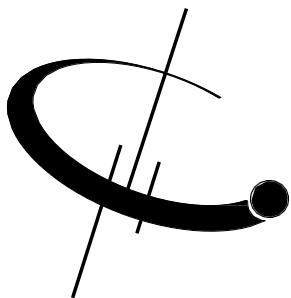

SOA-1310-BP

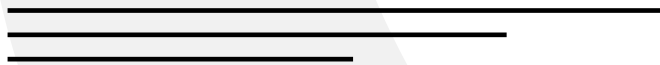

RELATED MODULE

- **SOA-1310-M**



The Optilab SOA-1310-M is a semiconductor optical amplifier with high fiber-to-fiber gain for OEM integration in MSA housing.

