

# Coherent Optical Receiver (CORX)



## Feature Overview

- ✓ High-bandwidth Dual Polarization Coherent Receiver Device
- ✓ 60 GHz, 20 GHz and 10 GHz variants
- ✓ Built-in Trans Impedance Amplifier
- ✓ Built-in local oscillator laser source
- ✓ USB & Ethernet interface for remote control
- ✓ SCPI style remote control command set
- ✓ Built-in Web Server for instant access from any browser enabled device
- ✓ 19 Inch 1HE Rack mount chassis

## Applications

- ✓ Optical Frontend for Oscilloscopes
- ✓ Testing of advanced optical modulation formats (e.g. QPSK, 16-QAM, ...)
- ✓ Reference receiver
- ✓ Testing coherent optical transmitters
- ✓ DWDM transmission experiments for system design tests
- ✓ Coherent detection DSP design

The Coherent Optical Receiver (CORX) is a fully integrated optical receiver instrument that mixes optical signals with a local oscillator signal and a polarization diverse detector setup with 4 output channels. This device provides excellent quality and matched channels optimized for analysis of dual polarization multi-level transmission formats at very high symbol rates. It is suitable as a reference receiver setup for transmitter characterization and analysis of IQ modulated optical signals in C-Band. The unit comprises trans-impedance amplifiers to allow real-time Oscilloscopes or A-D connection even for low power signals. Per channel variable RF gain and peaking allows to adapt and compensate for imperfections of the RF chain. A built-in tunable laser can be used as the local oscillator for coherent mixing of the signal. The unit is controlled via a built-in Webserver eliminating the need for software installation on a remote PC and enabling any handheld device to access the unit via browser. A SCPI based programming API allows straightforward implementation of automated test scripting and remote control.

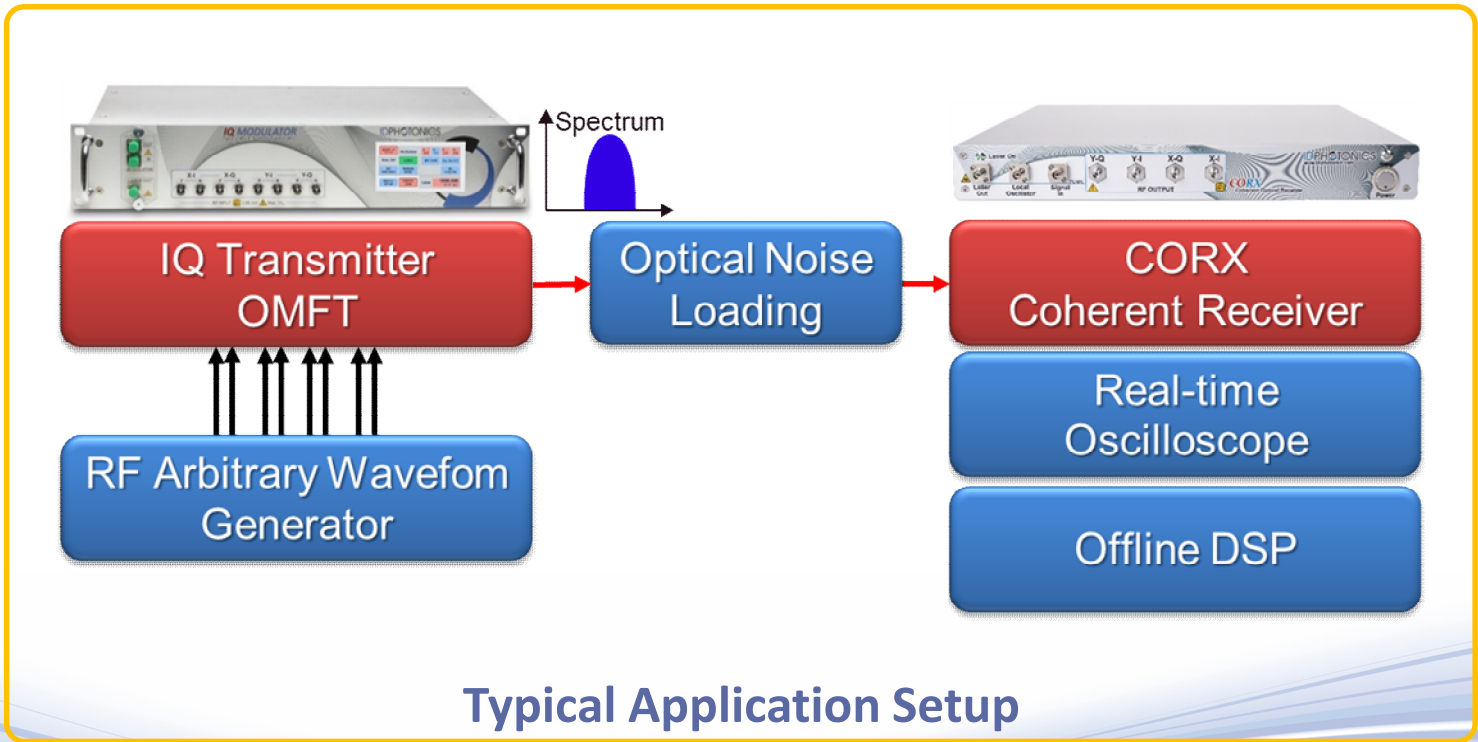
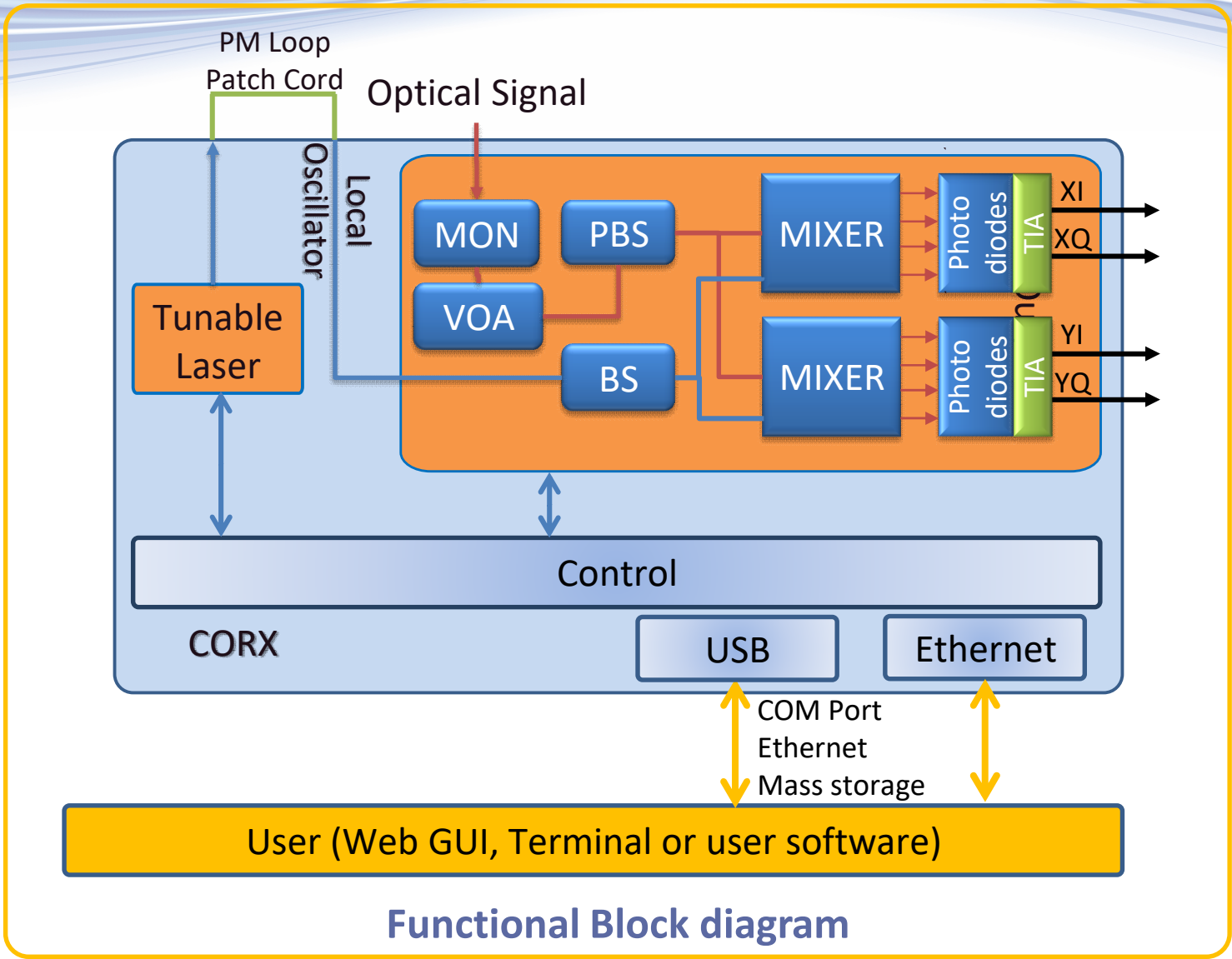

# Specification – Receiver

Parameter	Class 20		Class 40		Class 60		unit
	typ.	min/m ax	typ.	min/m ax	typ.	min/m ax	
<b>RF Specification</b>							
E/O Bandwidth, norm. to 1 GHz, -6dB	20	18	40	38	60	55	GHz
Low frequency cutoff, -3dB		1		1		1	MHz
RF Output swing		600		600		600	mV
THD		5		5		5	%
RF CMRR, at specified bandwidth		-20		-20		-20	dBe
DC Common Mode Rejection Ratio,Signal, LO		-20		-20		-20	dBe
IQ Skew		+/- 3		+/- 3		+/- 3	ps
X to Y Skew		+/- 5		+/- 5		+/- 5	ps
Output impedance		50		50		50	Ohm
Output Return Loss		8		8		8	dB
RF Connectors, female		1.85		1.85		1.85	mm
<b>Optical Specification</b>							
Operating Wavelength Range		1528 - 1568		1528 - 1568		1528 - 1568	nm
Polarization Extinction Ratio		17		17		17	dB
Optical Return Loss @1550nm		27		27		27	dB
Phase Angle Error		+/- 5		+/- 5		+/- 5	deg
Responsivity		0.035		0.035		0.035	A/W
VOA Attenuation range	-	10	-	10	-	10	dB
Optical Connector		FC/APC		FC/APC		FC/APC	-
<b>Optical Operating Conditions</b>							
Max. LO optical input Power		16		16		16	dBm
Max. Signal Input Power Level		0		0		0	dBm
<b>Absolute Maximum Ratings</b>							
Max. Optical Input Power (LO + Signal IN)		20		20		20	dBm
<b>Device Specification</b>							
Dimensions (W x H x D), w/0 19" adaptor	365 x 45 x 275mm, 19 x 1.75 x 14.4 inch						
Weight	3 kg, 6.6 lbs						
Electrical Power Supply	100-240 VAC, 1A, 50/60Hz, 80Watt, C13 connector						
Operating Temperature	+10 to +35, non-condensing						Deg C



## Specification - Internal Laser

Optical Parameter	Specification	Unit	
Frequency range; C – Band	190.70 – 196.65 (1524.5 - 1572nm)	THz	
Channel Spacing	Continuous	GHz	
Frequency Fine Tune Resolution	1	MHz	
Frequency Fine Tune Range	+/- 6GHz	GHz	
Optical Power Range, before modulator path	10 – 16	dBm	
Spectral Line Width; 3dB instantaneous, 3.5us (Lorentzian contribution)	< 100 25 typical	kHz	
Frequency accuracy	Over Lifetime Over 24 hours	+/- 1.5 +/- 0.3	GHz
SMSR; Side mode suppression ratio	> 40 (50typ.)	dB	
RIN (10MHz to 3GHz)	< -145 (up to 40GHz)	dB/Hz	
Output Power accuracy over Lifetime	+/- 0.01 (typ.)	dB	
Over 1 hour	+/- 0.03 (typ.)		
Over 24 hours			
Output Power Setting Resolution	0.01	dB	
Optical Fiber	Polarization- maintaining PANDA type Fiber, PER > 20dB, 25dB typ.		

## Ordering information

Part Number	Description
CO-RX-Cxx-10-FA	Coherent Optical Receiver unit xx: (20/40/60) for Speed class of device
CORX-ACC-RF-03-MM	Set of 4pc RF cables, 30cm,+/-1ps delay matched, 1.85mm Male-to-Male straight, DC – 67GHz
CORX-ACC-RM	Mechanical adaptor kit for 19" rack mount of CORX device

### Contact information

ID Photonics GmbH  
Anton-Bruckner-Str. 6  
85579 Neubiberg  
GERMANY  
Tel.: + 49 (0) 89 – 201 899 16

[info@id-photonics.com](mailto:info@id-photonics.com)  
[www.id-photonics.com](http://www.id-photonics.com)



**Invisible Laser Radiation**  
**Class 1M Laser Product**  
EN 60825-1: IEC 60825-1