

EOLP-1314G-10-X

1310nm SFP+ single-Mode Transceiver, With Diagnostic Monitoring
Multi-rate 16x / 8x / 4x Fiber Channel
Duplex SFP+ Transceiver, RoHS 6 Compliant

Features

- ◆ Operating data rate up to 14.025Gbps
- ◆ 1310nm DFB-LD Transmitter
- ◆ Distance up to 10km
- ◆ Single 3.3V Power supply and TTL Logic Interface
- ◆ Duplex LC Connector Interface
- ◆ Hot Pluggable
- ◆ Power Dissipation < 1.2W
- ◆ Compliant with MSA SFP+ Specification SFF-8431
- ◆ Compliance with Fiber Channel FC-PI-5
- ◆ Compliant with 16G/8G/4G Fiber Channel
- ◆ Operating Case Temperature:
 Standard: 0°C ~ +70°C
 Industrial: -40°C ~ +85°C



Applications

- ◆ Multi-rate 16x / 8x / 4x Fiber Channel

Ordering information

Part No.	Data Rate	Laser	Fiber Type	Distance	Optical Interface	Temp.	DDMI
EOLP-1314G-10*Note1	14.025 Gbps	1310nm DFB	SMF	10km	LC	0°C ~ +70°C	YES
EOLP-1314G-10-I*Note2	14.025 Gbps	1310nm DFB	SMF	10km	LC	-40°C ~ +85°C	YES

Note1: Standard version.

Note2: Industrial version.

*The product image only for reference purpose.

Regulatory Compliance^{*Note3}

Product Certificate	Certificate Number	Applicable Standard
TUV	R50135086	EN 60950-1:2006+A11+A1+A12+A2
		EN 60825-1:2014
		EN 60825-2:2004+A1+A2
UL	E317337	UL 60950-1
		CSA C22.2 No. 60950-1-07
EMC CE	AE 50384190 0001	EN 55032:2012
		EN 55032:2015
		EN 55024:2010
		EN 55024:2010+A1
FCC	WTF14F0514417E	47 CFR PART 15 OCT., 2013
FDA	/	CDRH 1040.10
ROHS	/	2011/65/EU

Note3: The above certificate number updated to June 2018, because some certificate will be updated every year, such as FDA and ROHS. For the latest certification information, please check with Eoptolink.

Product Description

The EOLP-1314G-10-X series single mode transceiver is small form factor pluggable module for serial optical data communications such as 16x/8x/4x Fiber Channel. It is with the SFP+ 20-pin connector to allow hot plug capability.

This module is designed for single mode fiber and operates at a nominal wavelength of 1310 nm. The transmitter section uses a 1310nm multiple quantum well DFB laser and is a class 1 laser compliant according to International Safety Standard IEC-60825.

The receiver section uses an integrated InGaAs detector preamplifier (IDP) mounted in an optical header and a limiting post-amplifier IC.

Absolute Maximum Ratings^{*Note4}

Parameter	Symbol	Min.	Max.	Unit
Storage Temperature	T _s	-45	+100	°C
Supply Voltage	V _{cc}	-0.5	4	V
Operating Relative Humidity	RH	5	95	%

Note4: Exceeding any one of these values may destroy the device permanently.

Recommended Operating Conditions

Parameter	Symbol	Min.	Typical	Max.	Unit
Operating Case Temperature	T _c	Standard	0	+70	°C
		Industrial	-40	+85	
Power Supply Voltage	V _{cc}	3.15	3.3	3.45	V

Power Supply Current	I _{cc}			360	mA
Surge Current	I _{Surge}			+30	mA
Baud Rate		4.25/8.5/14.025			Gbps

Performance Specifications – Electrical

Parameter	Symbol	Min.	Typ.	Max	Unit	Notes
Transmitter						
CML Inputs(Differential)	V _{in}	200		900	mVpp	AC coupled inputs
Input Impedance (Differential)	Z _{in}	85	100	115	ohm	R _{in} > 100 kohms @ DC
Tx_DISABLE Input Voltage – High		2		V _{cc} +0.3	V	
Tx_DISABLE Input Voltage – Low		-0.3		0.8	V	
Tx_FAULT Output Voltage – High		2		V _{cc} +0.3	V	I _o = 400μA; Host V _{cc}
Tx_FAULT Output Voltage – Low		0		0.5	V	I _o = -4.0mA
Receiver						
CML Outputs (Differential)	V _{out}	300		1000	mVpp	AC coupled outputs
Rx_LOS Output Voltage – High		2		V _{cc} +0.3	V	I _o = 400μA; Host V _{cc}
Rx_LOS Output Voltage – Low		-0.3		0.8	V	I _o = -4.0mA
MOD_DEF (0:2)	VoH	2.5			V	With Serial ID
	VoL	0		0.5	V	

Performance Specifications – Optical

Parameter	Symbol	Min.	Typical	Max.	Unit
9μm Core Diameter SMF				10	Km
Data Rate		4.25/8.5/14.025			Gbps
Transmitter					
Centre Wavelength	λ _c	1295	1310	1325	nm
Spectral Width (-20dB)	Δλ			1	nm
Average Output Power@14.025Gb/s *Note5	P _{out}	-5		+2	dBm
Extinction Ratio@14.025Gb/s	ER	3.5			dB
Average Power of OFF Transmitter	P _{off}			-30	dBm
Side Mode Suppression Ratio	SMSR	30			dB
Transmitter Dispersion Penalty	TDP			4.4	dB
Input Differential Impedance	Z _{IN}	90	100	110	Ω
TX Disable Assert Time	t _{off}	-	-	10	us
TX_DISABLE Negate Time	t _{on}	-	-	1	ms

TX_BISABLE time to start reset	t_reset	10	-	-	us
Time to initialize, include reset of TX_FAULT	t_init	-	-	300	ms
TX_FAULT from fault to assertion	t_fault	-	-	100	us
Receiver					
Centre Wavelength	λ	1260		1370	nm
Sensitivity(OMA)@14.025Gb/s* ^{Note6}	P _{min}			-12	dBm
Receiver Overload	P _{max}	2			dBm
Optical Return Loss	ORL			-12	dB
LOS De-Assert@14.025Gb/s	LOS _D			-19	dBm
LOS Assert@14.025Gb/s	LOS _A	-30			dBm

Note5: Output is coupled into a 9/125um SMF.

Note6: Minimum average optical power measured at the BER less than 1E-12, back to back. The measure pattern is PRBS 2³¹-1.

SFP+ Transceiver Electrical Pad Layout

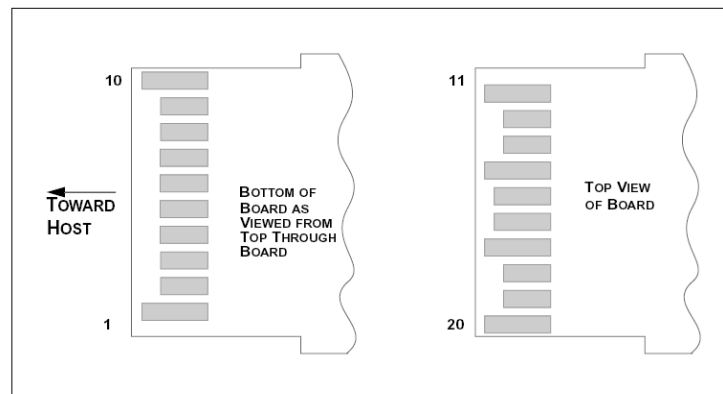
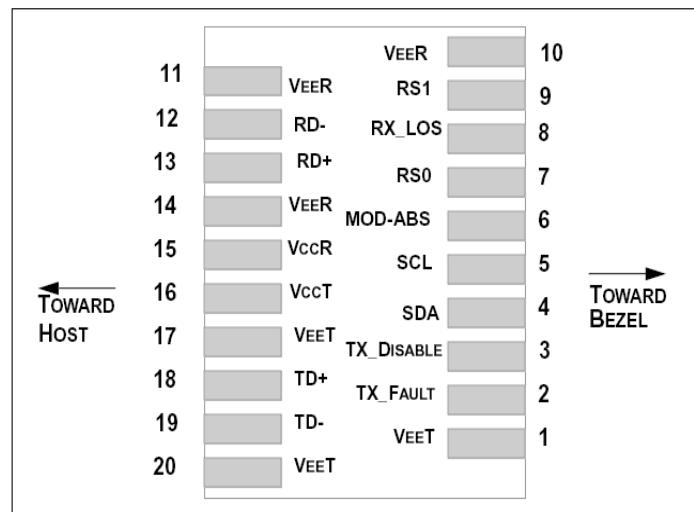

Pin Function Definitions

Pin Num.	Name	FUNCTION	Plug Seq.	Notes
1	VeeT	Transmitter Ground	1	Note 5
2	TX Fault	Transmitter Fault Indication	3	Note 1
3	TX Disable	Transmitter Disable	3	Note 2, Module disables on high or open
4	SDA	Module Definition 2	3	2-wire Serial Interface Data Line.
5	SCL	Module Definition 1	3	2-wire Serial Interface Clock.
6	MOD-ABS	Module Definition 0	3	Note 3
7	RS0	RX Rate Select (LVTTL).	3	Rate Select 0, optionally controls SFP+ module receiver. This pin is pulled low to VeeT with a >30K resistor..
8	RX LOS	Loss of Signal	3	Note 4
9	RS1	TX Rate Select (LVTTL).	1	Rate Select 1, optionally controls SFP+ module transmitter. This pin is pulled low to VeeT with a >30K resistor.
10	VeeR	Receiver Ground	1	Note 5
11	VeeR	Receiver Ground	1	Note 5
12	RD-	Inv. Received Data Out	3	Note 6
13	RD+	Received Data Out	3	Note 7
14	VeeR	Receiver Ground	1	Note 5
15	VccR	Receiver Power	2	3.3V ± 5%, Note 7
16	VccT	Transmitter Power	2	3.3V ± 5%, Note 7
17	VeeT	Transmitter Ground	1	Note 5
18	TD+	Transmit Data In	3	Note 8
19	TD-	Inv. Transmit Data In	3	Note 8
20	VeeT	Transmitter Ground	1	Note 5

Notes:

1) TX Fault is an open collector/drain output, which should be pulled up with a 4.7K – 10KΩ resistor on the host board. Pull up voltage between 2.0V and VccT/R+0.3V. When high, output indicates a laser fault of some kind. Low indicates normal operation. In the low state, the output will be pulled to < 0.8V.

2) TX disable is an input that is used to shut down the transmitter optical output. It is pulled up within the module with a 4.7K – 10 KΩ resistor. Its states are:

Low (0 – 0.8V): Transmitter on

(>0.8, < 2.0V): Undefined

High (2.0 – 3.465V): Transmitter Disabled

Open: Transmitter Disabled

- 3) Module Absent, connected to VeeT or VeeR in the module.
- 4) RX LOS (Loss of Signal) is an open collector/drain output, which should be pulled up with a 4.7K – 10KΩ resistor. Pull up voltage between 2.0V and $V_{ccT/R}+0.3V$. When high, this output indicates the received optical power is below the worst-case receiver sensitivity (as defined by the standard in use). Low indicates normal operation. In the low state, the output will be pulled to $< 0.8V$.
- 5) The module signal ground contacts, VeeR and VeeT, should be isolated from the module case.
- 6) RD-/+ : These are the differential receiver outputs. They are AC coupled 100Ω differential lines which should be terminated with 100Ω (differential) at the user SERDES. The AC coupling is done inside the module and is thus not required on the host board.
- 7) VccR and VccT are the receiver and transmitter power supplies. They are defined as 3.3V $\pm 5\%$ at the SFP+ connector pin. Maximum supply current is 360mA. Inductors with DC resistance of less than 1 ohm should be used in order to maintain the required voltage at the SFP+ input pin with 3.3V supply voltage. When the recommended supply-filtering network is used, hot plugging of the SFP+ transceiver module will result in an inrush current of no more than 30mA greater than the steady state value. VccR and VccT may be internally connected within the SFP+ transceiver module.
- 8) TD-/+ : These are the differential transmitter inputs. They are AC-coupled, differential lines with 100Ω differential termination inside the module. The AC coupling is done inside the module and is thus not required on the host board.

EEPROM

The serial interface uses the 2-wire serial CMOS EEPROM protocol. When the serial protocol is activated, the host generates the serial clock signal (SCL). The positive edge clocks data into those segments of the EEPROM that are not written protected within the SFP+ transceiver. The negative edge clocks data from the SFP+ transceiver. The serial data signal (SDA) is bi-directional for serial data transfer. The host uses SDA in conjunction with SCL to mark the start and end of serial protocol activation. The memories are organized as a series of 8-bit data words that can be addressed individually or sequentially.

The Module provides diagnostic information about the present operating conditions. The transceiver generates this diagnostic data by digitization of internal analog signals. Calibration and alarm/warning threshold data is written during device manufacture. Received power monitoring, transmitted power monitoring, bias current monitoring, supply voltage monitoring and temperature monitoring all are implemented. If the module is defined as external calibrated, the diagnostic data are raw A/D values and must be converted to real world units using calibration constants stored in EEPROM locations 56 – 95 at wire serial bus address A2h. The digital diagnostic memory map specific data field define as following .For detail EEPROM information, please refer to the related document of SFF 8472 Rev 10.2.

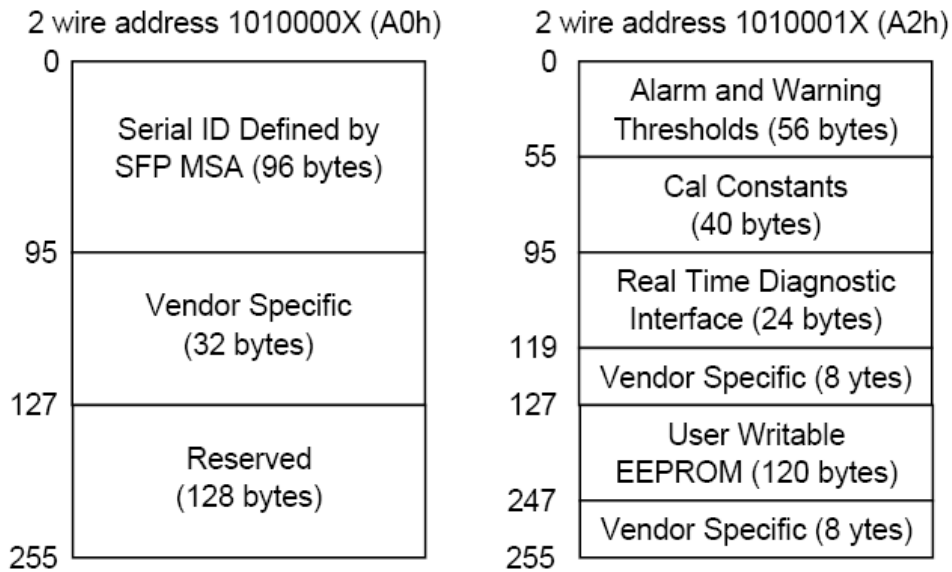

Rate_Select Operation

The EOLP-1314G-10-X supports 14.025G/8.5G/4.25G, and Rate_Select is compliant with SFF-8472 Rev12.2.

Logic OR of RS0 pin and bit 110.3 of A2H	Logic OR of RS1 pin and bit 118.3 of A2H	RX Data Rate	TX Data Rate
High	High	14.025G	14.025G
Low	Low	8.5G/4.25G	8.5G/4.25G

Recommend Circuit Schematic

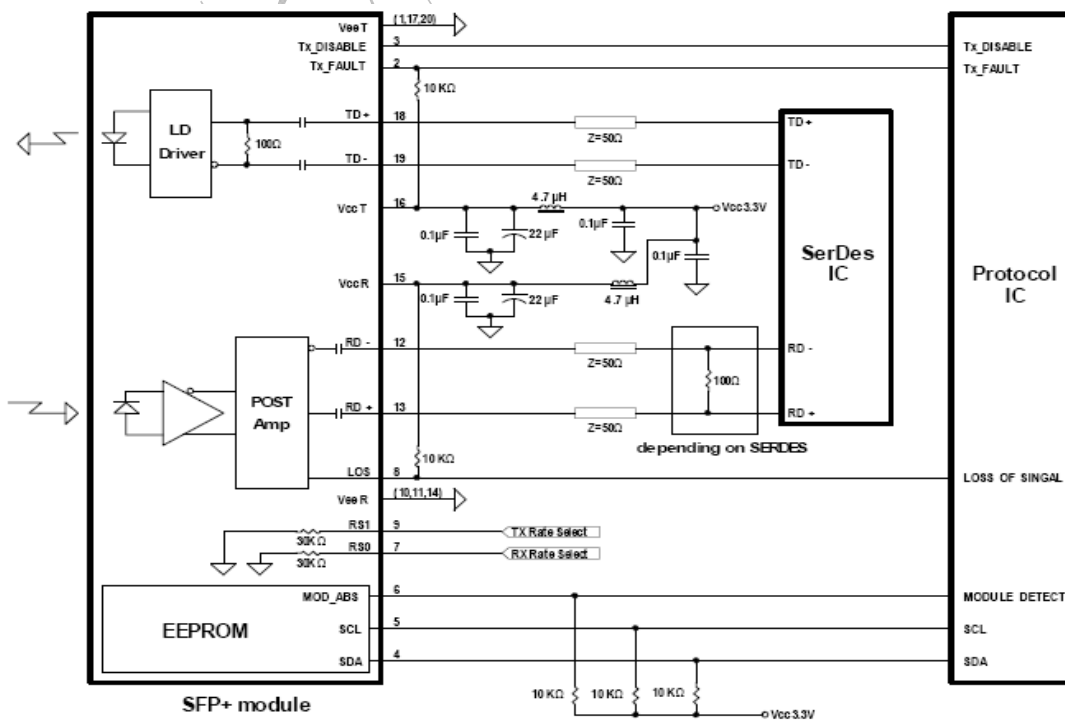

Mechanical Specifications

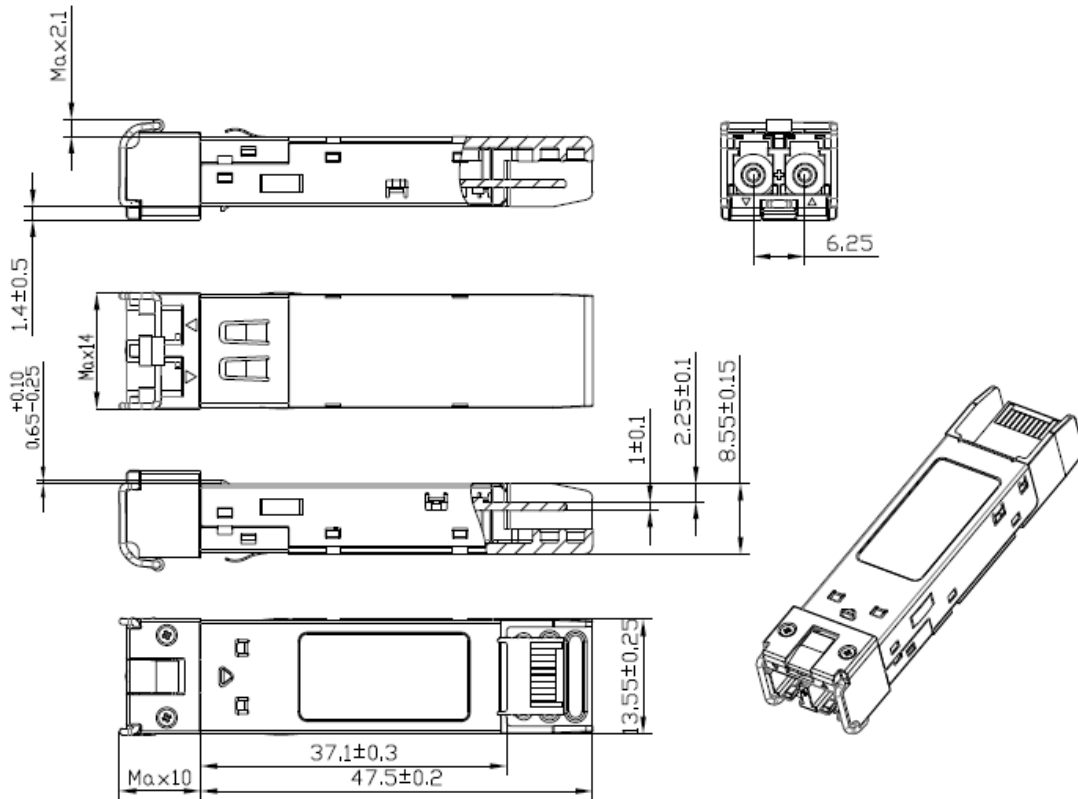

Unremarked tolerances ±0.2mm

*This 2D drawing only for reference, please check with Eoptolink before ordering.

Eye Safety

This single-mode transceiver is a Class 1 laser product. It complies with IEC-60825 and FDA 21 CFR 1040.10 and 1040.11. The transceiver must be operated within the specified temperature and voltage limits. The optical ports of the module shall be terminated with an optical connector or with a dust plug.

Obtaining Document

You can visit our website:

<http://www.eoptolink.com>

Or contact Eoptolink Technology Inc., Ltd. Listed at the end of the documentation to get the latest document.

Revision History

Revision	Initiated	Reviewed	Approved	Revision History	Release Date
V1.a	Frank.Wu			Preliminary	2013-9-5
V1.b	Roty	Picard/Airon/William		Update the Regulatory Compliance, Electrical/Optical Characteristics and Mechanical Specifications	Apr 28, 2017
V1.c	Roty	Airon/Sky		Update CML Outputs, Add Rate_Select Operation	Jul 21, 2017
V1.d	Roty	Marvin/Airon/Nico/Kelly		Add Industrial version. Updated the regulatory compliance and mechanical specifications.	Sep 12, 2018

Notice:

Eoptolink reserves the right to make changes to or discontinue any optical link product or service identified in this publication, without notice, in order to improve design and/or performance. Applications that are described herein for any of the optical link products are for illustrative purposes only. Eoptolink makes no representation or warranty that such applications will be suitable for the specified use without further testing or modification.

Contact:

Add: No.127 West Wulian Street, Gongxing Town, Shuangliu district, Chengdu City, Sichuan, China.

Tel: (+86) 028-67087999

Fax: (+86) 28-67087979-8010

Postal: 610213

E-mail:sales@eoptolink.com

<http://www.eoptolink.com>