

# EOLP-8596-02-X

**850nm SFP+ Multi-Mode Transceiver, With Diagnostic Monitoring**

**10G BASE-SW/SR**

**0.6~10Gb/s CPRI/OBSAI**

**Duplex SFP+ Transceiver, RoHS Compliant**

## Features

- ◆ Operating Data Rate up to 11.3Gbps
- ◆ 850nm VCSEL Transmitter
- ◆ Distance up to 300m @50 / 125 um MMF
- ◆ Single 3.3V Power Supply and TTL Logic Interface
- ◆ Duplex LC Connector Interface, Hot Pluggable
- ◆ Compliant with MSA SFP+ Specification SFF-8431
- ◆ Compliant with IEEE 802.3ae 10GBASE-SR/SW
- ◆ Power Dissipation < 1.0W
- ◆ Dispersion Tolerance up to 40ps/nm over G.651
- ◆ Operating Case Temperature
  - Standard: 0°C~+70°C
  - Industrial: -40°C~85°C
  - Extended: -20°C~75°C
- ◆ Safety Certification: TUV/UL/FDA\*<sup>Note1</sup>
- ◆ RoHS Compliant



## Applications

- ◆ 10GBASE-SW at 9.953 Gbps
- ◆ 10GBASE-SR at 10.3125 Gbps
- ◆ OBSAI Rates 6.144 Gb/s, 3.072 Gb/s, 1.536 Gb/s, 0.768 Gb/s
- ◆ CPRI Rates 10.138 Gb/s, 9.830 Gb/s, 7.373 Gb/s, 6.144 Gb/s, 4.915 Gb/s, 2.458 Gb/s, 1.229 Gb/s, 0.614 Gb/s
- ◆ Other Optical Link

## Ordering information

Part No.	Data Rate	Laser	Fiber Type	Distance	Temp.	DDMI
EOLP-8596-02	0.614Gbps to 11.3Gbps	850nm VCSEL	MMF	300m	Standard	YES
EOLP-8596-02-I	0.614Gbps to 11.3Gbps	850nm VCSEL	MMF	300m	Industrial	YES
EOLP-8596-02-E	0.614Gbps to 11.3Gbps	850nm VCSEL	MMF	300m	Extended	YES

Note 1: For the latest certification information, please check with Eoptolink.

\*The product image only for reference purpose.

## Product Description

The EOLP-8596-02-X series multi-mode transceiver is SFP+ module for duplex optical data communications such as 10GBASE-SR and 10GBASE-SW. It is with the SFP+ 20-pin connector to allow hot plug capability. Digital diagnostic functions are available via an I<sup>2</sup>C. This module is designed for multi-mode fiber and operates at a nominal wavelength of 850 nm.

The transmitter section uses a Vertical Cavity Surface Emitted Laser (VCSEL) and is a Class 1 laser compliant according to International Safety Standard IEC 60825. The receiver section uses an integrated GaAs detector preamplifier (IDP) mounted in an optical header and a limiting post-amplifier IC.

## Absolute Maximum Ratings<sup>\*Note2</sup>

Parameter	Symbol	Min.	Max.	Unit
Storage Temperature	T <sub>s</sub>	-40	+85	°C
Supply Voltage	V <sub>CC</sub>	-0.5	3.6	V
Input Voltage	V <sub>in</sub>	-0.5	V <sub>CC</sub>	V
Output Current	I <sub>o</sub>	-	50	mA
Relative Humidity <sup>*Note3</sup>	RH	0	85	%

Note 2: Exceeding any one of these values may destroy the device permanently.

Note 3: Non-condensing.

## Recommended Operating Conditions

Parameter	Symbol	Min.	Typ.	Max.	Unit	
Operating Case Temperature	T <sub>c</sub>	EOLP-8596-02	0		70	°C
		EOLP-8596-02-I	-40		85	
		EOLP-8596-02-E	-20		75	
Power Supply Voltage	V <sub>CC</sub>	3.15	3.3	3.45	V	
Power Supply Current	I <sub>CC</sub>			300	mA	
Surge Current	I <sub>Surge</sub>			+30	mA	
Baud Rate		0.6		11.3	Gbps	

## Performance Specifications – Electrical

Parameter	Symbol	Min.	Typ.	Max.	Unit	Notes
<b>Transmitter</b>						
CML Inputs (Differential)	V <sub>in</sub>	150		1200	mVpp	AC coupled inputs
Input Impedance (Differential)	Z <sub>in</sub>	85	100	115	ohms	R <sub>in</sub> > 100 kohms @ DC

Tx_DISABLE Input Voltage – High		2		V <sub>cc</sub> +0.3	V	
Tx_DISABLE Input Voltage – Low		0		0.8	V	
Tx_FAULT Output Voltage – High		2		V <sub>cc</sub> +0.3	V	I <sub>o</sub> = 400μA; Host V <sub>cc</sub>
Tx_FAULT Output Voltage – Low		0		0.8	V	I <sub>o</sub> = -4.0mA
<b>Receiver</b>						
CML Outputs (Differential)	V <sub>out</sub>	350		700	mVpp	AC coupled outputs
Output Impedance (Differential)	Z <sub>out</sub>	85	100	115	ohms	
Rx_LOS Output Voltage – High		2		V <sub>cc</sub> +0.3	V	I <sub>o</sub> = 400μA; Host V <sub>cc</sub>
Rx_LOS Output Voltage – Low		0		0.8	V	I <sub>o</sub> = -4.0mA
MOD_DEF (2:0)	VoH	2.5			V	With Serial ID
	VoL	0		0.5	V	

### Optical and Electrical Characteristics

Parameter	Symbol	Min.	Typ.	Max.	Unit
50 / 125 um MMF			300		m
Data Rate		0.6		11.3	Gbps
<b>Transmitter</b>					
Centre Wavelength	λ <sub>c</sub>	840	850	860	nm
Spectral Width (RMS)	Δλ			0.45	nm
Average Output Power	P <sub>out</sub>	-6		-1	dBm
Extinction Ratio	ER	3.0	5.0		dB
Output Optical Eye		IEEE 802.3-2005 Compliant			
Transmitter Dispersion Penalty	TDP			3.9	dB
TX_Disable Assert Time	t <sub>off</sub>			10	us
TX_DISABLE Negate Time	t <sub>on</sub>	-	-	1	ms
TX_BISABLE time to Start Reset	t <sub>reset</sub>	10	-	-	us
Time to Initialize, Include Reset of TX_FAULT	t <sub>init</sub>	-	-	300	ms
TX_FAULT from Fault to Assertion	t <sub>fault</sub>	-	-	100	us
Total Jitter	TJ	-	-	0.28	UI(p-p)
Data Dependent Jitter	DDJ	-	-	0.1	UI(p-p)
Uncorrelated Jitter	UJ	-	-	0.023	RMS

Receiver					
Centre Wavelength	$\lambda_c$	840	850	860	nm
Receiver Sensitivity (OMA) *Note4	Pmin			-11.1	dBm
Stressed Receiver Sensitivity (OMA) *Note4	Pmin			-7.5	dBm
Receiver Overload	Pmax	-1			dBm
Optical Return Loss	ORL			-12	dB
LOS De-Assert	LOS <sub>D</sub>			-12.5	dBm
LOS Assert	LOS <sub>A</sub>	-25			dBm
LOS Hysteresis		0.5			dB

Note 4: Measured with a PRBS 2<sup>31</sup> -1 test pattern @ 10.3125Gbps, BER ≤ 10<sup>-12</sup>

## SFP+ Transceiver Electrical Pad Layout

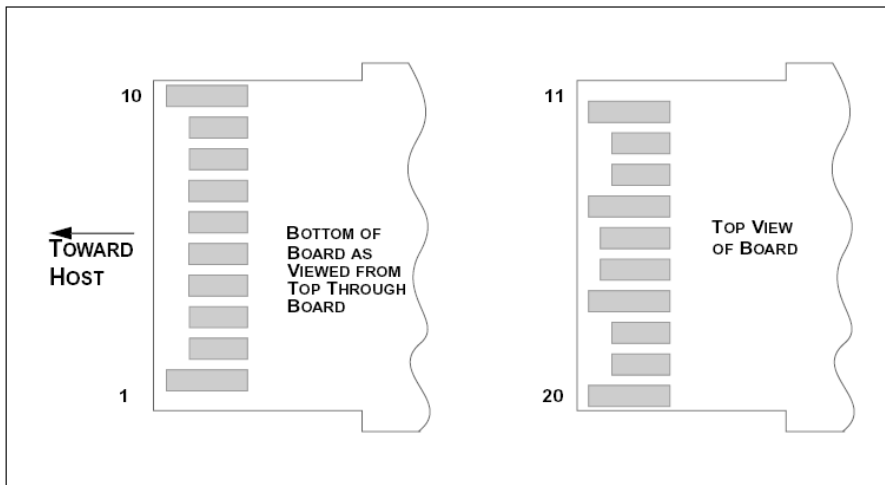
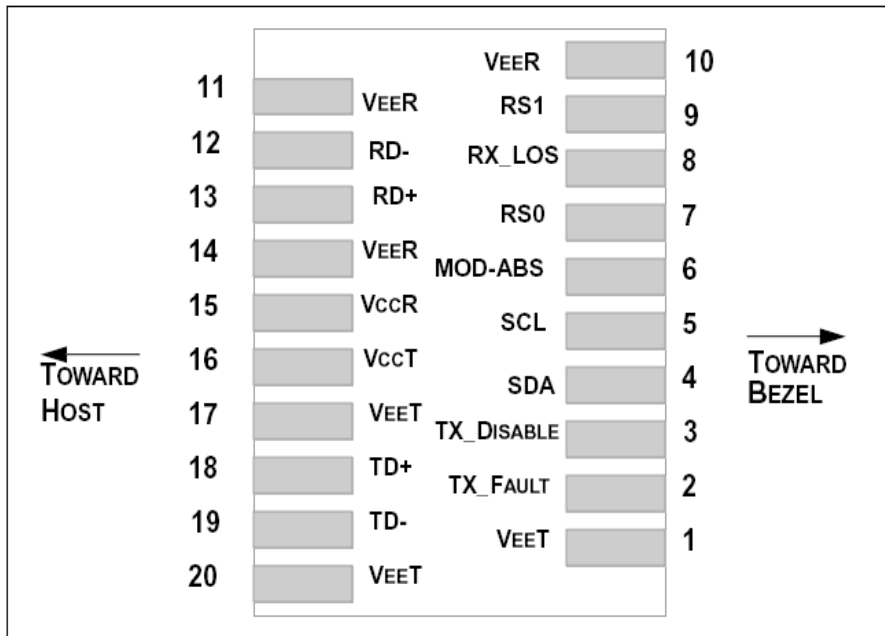

**Pin Function Definitions**

Pin Num.	Name	Function	Plug Seq.	Notes
1	VeeT	Transmitter Ground	1	Note 5
2	TX Fault	Transmitter Fault Indication	3	Note 1
3	TX Disable	Transmitter Disable	3	Note 2, Module disables on high or open
4	SDA	Module Definition 2	3	2-wire Serial Interface Data Line.
5	SCL	Module Definition 1	3	2-wire Serial Interface Clock.
6	MOD-ABS	Module Definition 0	3	Note 3
7	RS0	RX Rate Select (LVTTTL).	3	No Function Implement
8	LOS	Loss of Signal	3	Note 4
9	RS1	TX Rate Select (LVTTTL).	1	No Function Implement
10	VeeR	Receiver Ground	1	Note 5
11	VeeR	Receiver Ground	1	Note 5
12	RD-	Inv. Received Data Out	3	Note 6
13	RD+	Received Data Out	3	Note 6
14	VeeR	Receiver Ground	1	Note 5
15	VccR	Receiver Power	2	3.3V ± 5%, Note 7
16	VccT	Transmitter Power	2	3.3V ± 5%, Note 7
17	VeeT	Transmitter Ground	1	Note 5
18	TD+	Transmit Data In	3	Note 8
19	TD-	Inv. Transmit Data In	3	Note 8
20	VeeT	Transmitter Ground	1	Note 5

**Notes:**

1) TX Fault is an open collector/drain output, which should be pulled up with a 4.7K – 10KΩ resistor on the host board. Pull up voltage between 2.0V and VccT/R+0.3V. When high, output indicates a laser fault of some kind. Low indicates normal operation. In the low state, the output will be pulled to < 0.8V.

2) TX disable is an input that is used to shut down the transmitter optical output. It is pulled up within the module with a 4.7K~10 K Ω resistor. Its states are:

Low (0 – 0.8V): Transmitter on

(>0.8, < 2.0V): Undefined

High (2.0 – 3.465V): Transmitter Disabled

Open: Transmitter Disabled

3) Module Absent, connected to VeeT or VeeR in the module.

- 4) LOS (Loss of Signal) is an open collector/drain output, which should be pulled up with a 4.7K – 10K $\Omega$  resistor. Pull up voltage between 2.0V and  $V_{ccT/R}+0.3V$ . When high, this output indicates the received optical power is below the worst-case receiver sensitivity (as defined by the standard in use). Low indicates normal operation. In the low state, the output will be pulled to < 0.8V.
- 5) The module signal ground contacts, VeeR and VeeT, should be isolated from the module case.
- 6) RD-/+ : These are the differential receiver outputs. They are AC coupled 100 $\Omega$  differential lines which should be terminated with 100 $\Omega$  (differential) at the user SERDES. The AC coupling is done inside the module and is thus not required on the host board. The voltage swing on these lines will be between 370 and 700 mV differential (185 –350 mV single ended) when properly terminated.
- 7) VccR and VccT are the receiver and transmitter power supplies. They are defined as 3.3V  $\pm$ 5% at the SFP+ connector pin. Maximum supply current is 300mA. Inductors with DC resistance of less than 1 ohm should be used in order to maintain the required voltage at the SFP+ input pin with 3.3V supply voltage. When the recommended supply-filtering network is used, hot plugging of the SFP+ transceiver module will result in an inrush current of no more than 30mA greater than the steady state value. VccR and VccT may be internally connected within the SFP+ transceiver module.
- 8) TD-/+ : These are the differential transmitter inputs. They are AC-coupled, differential lines with 100 $\Omega$  differential termination inside the module. The AC coupling is done inside the module and is thus not required on the host board. The inputs will accept differential swings of 150 – 1200 mV (75 – 600mV single-ended), though it is recommended that values between 150 and 1200 mV differential (75 – 600mV single-ended) be used for best EMI performance.

### EEPROM

The serial interface uses the 2-wire serial CMOS EEPROM protocol. When the serial protocol is activated, the host generates the serial clock signal (SCL). The positive edge clocks data into those segments of the EEPROM that are not writing protected within the SFP+ transceiver. The negative edge clocks data from the SFP+ transceiver. The serial data signal (SDA) is bi-directional for serial data transfer. The host uses SDA in conjunction with SCL to mark the start and end of serial protocol activation. The memories are organized as a series of 8-bit data words that can be addressed individually or sequentially.

The Module provides diagnostic information about the present operating conditions. The transceiver generates this diagnostic data by digitization of internal analog signals. Calibration and alarm/warning threshold data is written during device manufacture. Received power monitoring, transmitted power monitoring, bias current monitoring, supply voltage monitoring and temperature monitoring all are implemented. If the module is defined as external calibrated, the diagnostic data are raw A/D values and must be converted to real world units using calibration constants stored in EEPROM locations 56 – 95 at wire serial bus address A2H. The digital diagnostic memory map specific data field define as following. For detail EEPROM information, please refer to the related document of SFF 8472 Rev 10.2.

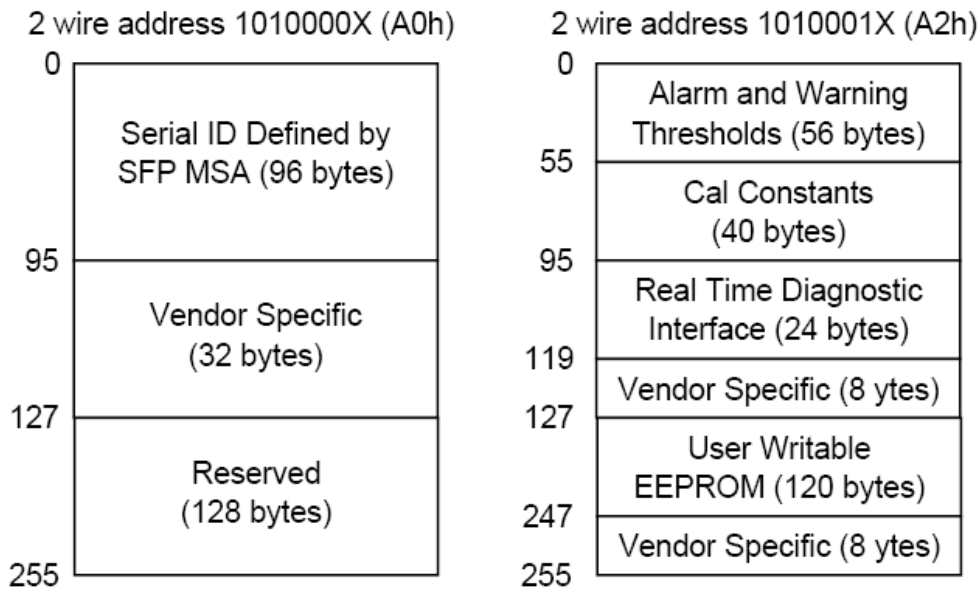

Data Addr	Field Size (Byte)	Name Of field	Description of field	Coded value	Hex
<b>BASE ID FIELDS</b>					
0	1	Identifier	Type of serial transceiver	SFP+	03
1	1	Ext.Identifier	Extended identifier of Type of serial transceiver	MOD_DEF 4	04
2	1	Connector	Code for connector type	LC	07
3	8	Transceiver	10G Ethernet Compliance Codes & Infiniband Compliance Codes	10G Base-SR	10
4			Part of SONET Compliance Codes		00
5			SONET Compliance Codes		00
6			Ethernet Compliance Codes		00
7			Fiber Channel link length & part of Fibre Channel technology		00
8			Part of Fiber Channel transmitter technology		00
9			Fiber Channel Transmission media		00
10			Fiber Channel speed		00
11	1	Encoding	Code for high speed serial encoding algorithm	64B/66B	06
12	1	BR, Nominal	Nominal signalling rate, units of 100MBd.	10.3Gbps	67
13	1	Rate Identifier	Type of rate select functionality		00

14	1	Length(SMF,km)	Link length supported for single mode fiber, units of km		00
15	1	Length (SMF)	Link length supported for single mode fiber, units of 100 m		00
16	1	Length (50um)	Link length supported for 50 um OM2 fiber, units of 10 m	80(m)	08
17	1	Length (62.5um)	Link length supported for 62.5 um OM1 fiber, units of 10 m	30(m)	03
18	1	Length (Copper)	Link length supported for copper, units of meters		00
19	1	Length (OM3)	Link length supported for 50 um OM3 fiber, units of 10 m	300(m)	1E
20	16	Vendor name	Vendor name (ASCII)	E	45
21				o	6F
22				p	70
23				t	74
24				o	6F
25				l	6C
26				i	69
27				n	6E
28				k	6B
29				<space>	20
30				<space>	20
31				<space>	20
32				<space>	20
33				<space>	20
34				<space>	20
35				<space>	20
36	1	Reserved			00
37	3	Vendor OUI	SFP vendor IEEE company ID		00
38					00
39					00
40	16	Vendor PN	Part number provided by vendor (ASCII)	E	45
41				O	4F
42				L	4C
43				P	50
44				-	2D
45				8	38
46				5	35
47				9	39
48				6	36
49				-	2D



50				0	30
51				2	32
52				-	2D
53				l/<space>	49/20
54				<space>	20
55				<space>	20
56	4	Vendor rev	Revision level for part number provided by vendor (ASCII)	1	31
57				.	2E
58				0	30
59				<space>	20
60	2	Wavelength	Laser Wavelength	850nm	05
61					32
62	1	Reserved			00
63	1	CC_BASE	Check code for Base ID Fields (addresses 0 to 62)	Note5	xx
64	2	Options	Indicates which optional transceiver signals are implemented	TX_DISABLE, TX_FAULT signal, Rx_LOS	00
65					1A
66	1	BR, max	Upper bit rate margin, units of %		00
67	1	BR, min	Lower bit rate margin, units of %		00
68	16	Vendor SN	Serial number provided by vendor (ASCII)	x	xx
69				x	xx
70				x	xx
71				x	xx
72				x	xx
73				x	xx
74				x	xx
75				x	xx
76				x	xx
77				x	xx
78				<space>	20
79				<space>	20
80				<space>	20
81				<space>	20
82				<space>	20
83				<space>	20
84	8	Date code	Vendor's manufacturing date code	Year	xx
85				Year	xx
86				Month	xx
87				Month	xx

88				Day	xx
89				Day	xx
90				<Space>	20
91				<Space>	20
92	1	Diagnostic Monitoring Type	Type of diagnostic monitoring is implemented	DD Implemented; Internally Calibrated; Average Power	68
93	1	Enhanced Options	Optional enhanced features are implemented	Optional Alarm/warning Flags Implemented, Optional soft TX_FAULT monitoring, Optional soft RX_LOS monitoring	B0
94	1	SFF-8472 Compliance	Revision of SFF-8472 the transceiver complies with	Rev 10.2 of SFF-8472.	03
95	1	CC_EXT	Check code for the Extended ID Fields (addresses 64 to 94)	Note6	
<p><b>Note5:</b> The check code shall be the low order 8 bits of the sum of the contents of all the bytes from byte 0 to byte 62, inclusive.</p>					
<p><b>Note6:</b> The check code shall be the low order 8 bits of the sum of the contents of all the bytes from byte 64 to byte 94, inclusive.</p>					

### Recommend Circuit Schematic

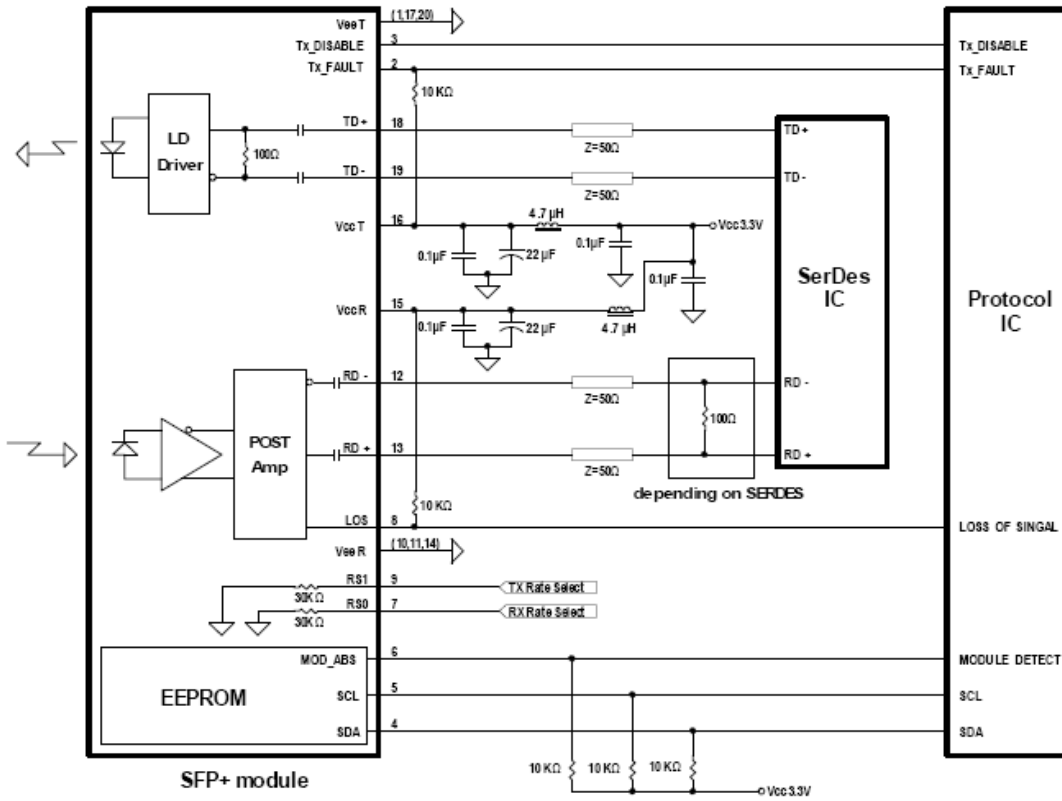

### Mechanical Specifications

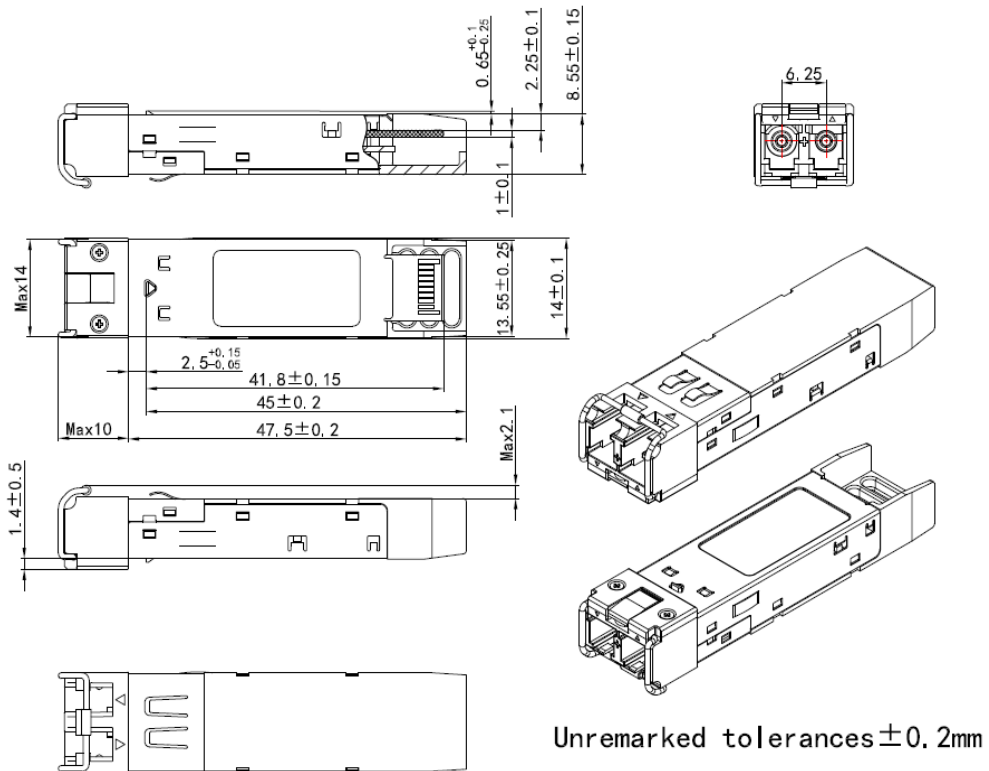

\*This 2D drawing only for reference, please check with Eoptolink before ordering

## Eye Safety

This single-mode transceiver is a Class 1 laser product. It complies with IEC-60825 and FDA 21 CFR 1040.10 and 1040.11. The transceiver must be operated within the specified temperature and voltage limits. The optical ports of the module shall be terminated with an optical connector or with a dust plug.

## Obtaining Document

You can visit our website:

<http://www.eoptolink.com>

Or contact Eoptolink Technology Inc., Ltd. Listed at the end of the documentation to get the latest documents.

## Revision History

Revision	Initiate	Review	Approve	Revision History	Release Date
V1.a	Tim	Kelly		Released	2008-9-13
V1.b	Phlio	Kelly		Adding the suitable applications.	2009-7-17
V1.c	Kelly			Change the logo.	2010-1-4
V1.d	Cathy			Update the low operating case temperature.	2010-7-15
V1.e	Cathy			Updated receiver sensitivity.	2011-4-8
V1.f	Kelly			Updating the extended type.	2011-5-13
V2.0	Alex/ Twonie	Kelly		Update part name	Aug 10, 2011
V2.a	Townie	Kelly		Add power dissipation.	Aug 23, 2011
V2.b	Kelly			Add dispersion tolerance.	Sep 6, 2011
V2.c	Kelly			Update SR/SW rate.	July 11, 2012
V2.d	Angela	Kelly		Update the part number for extended range.	July 19, 2012]
V2.e	Angela,	Kelly		Update pin definition notes	Jan 30, 2013
V2.f	Angela	Kelly		Add CPRI&OBSAI application	June 18, 2013
V2.g	Angela	Vina/Fing/ Jp/Eason/ Jason		Add industrial temperature range. Update max data rate, regulatory compliance and the tolerances of 2D drawing.	April 21,2015
V2.h	Angela			Update a slip of the pen.	July 8,2015
V2.i	Angela	Kelly		Update the regulatory compliance and corrected some slip of the pen.	April 14,2016
V2.j	Angela	Kelly/Vina		Update the CPRI data rates	July 17, 2017

		/Dean/ Chao.Wang		and 2D drawing.	
V2.k	Angela/ Yi.Wan	Young		Add the EEPROM contents of A0h.	August 11, 2017
V2.l	Elaine	Kelly/Marvin/ Fing		Add the extended temperature and update the contact.	Jan 23, 2018
V2.m	Angela	Kelly/Fing/ JP/Eason/ William/ Chao.Wang	Phlio	Update the RS0/RS1 Pin function definition notes. Update the picture and 2D drawing.	March 23, 2018
V2.n	Angela	Kelly		Updated the regulatory compliance.	August 27, 2018
V2.o	Nico	Marvin/Kelly/ Angela/Yi Wan		Add the parameter of stressed receiver sensitivity(OMA). Changed the “receiver sensitivity” to “receiver sensitivity(OMA)” . Updated the regulatory compliance.	Jul 18, 2019

**Notice:**

Eoptolink reserves the right to make changes to or discontinue any optical link product or service identified in this publication, without notice, in order to improve design and/or performance. Applications that are described herein for any of the optical link products are for illustrative purposes only. Eoptolink makes no representation or warranty that such applications will be suitable for the specified use without further testing or modification.

**Contact:**

Add: No.127 West Wulian Street, Gongxing Town, Shuangliu district, Chengdu City, Sichuan, China.

Tel: (+86) 028-67087999

Fax: (+86) 28-67087979-8010

Postal: 610213

E-mail: sales@eoptolink.com

<http://www.eoptolink.com>