

EOLP-BI1696-9ADL & EOLP-BI1696-9DAL Series

Tx: 1270nm/Rx: 1330nm BIDI SFP+ Transceiver for 10GbE

Tx: 1330nm/Rx: 1270nm BIDI SFP+ Transceiver for 10GbE

RoHS Compliant

Features

- ◆ Operating data rate up to 11.3Gbps
- ◆ Two types:
 - A: 1270nm DFB Transmitter/ 1330nm Receiver
 - B: 1330nm DFB Transmitter/ 1270nm Receiver
- ◆ Power budget 9dB at least
- ◆ Single 3.3V Power supply and TTL Logic Interface
- ◆ LC Connector Interface
- ◆ Hot Pluggable
- ◆ Power Dissipation < 1.5W
- ◆ Operating Case Temperature
 - Standard: 0~+70°C
 - Industrial: -40~+85°C
- ◆ Compliant with SFP+ MSA Specification SFF-8431
- ◆ Compliant with IEEE 802.3ae 10GBASE-LR
- ◆ Compliant with IEEE 802.3ae 10GBASE-LW
- ◆ Compliant with SFF-8472
- ◆ Safety Certification: TUV/UL/FDA*^{Note1}
- ◆ RoHS Compliant



Applications

- ◆ 10GBASE-LR at 10.3125Gbps
- ◆ 10GBASE-LW at 9.953Gbps
- ◆ OBSAI rates 6.144 Gb/s, 3.072 Gb/s, 1.536 Gb/s, 0.768Gb/s
- ◆ CPRI rates 10.138Gb/s , 9.830 Gb/s, 7.373Gb/s, 6.144 Gb/s, 4.915 Gb/s, 2.458 Gb/s, 1.229 Gb/s, 0.614Gb/s
- ◆ Other Optical Links

Ordering information

Part No.	Data Rate	Laser	Temp.	Power budget	Optical Interface	DDMI
EOLP-BI1696-9ADL* <small>Note2</small>	Up to 11.3Gbps	1270nm DFB	Standard	9dB	LC	YES
EOLP-BI1696-9DAL* <small>Note2</small>	Up to 11.3Gbps	1330nm DFB	Standard	9dB	LC	YES
EOLP-BI1696-9ADIL	Up to 11.3Gbps	1270nm	Industrial	9dB	LC	YES

		DFB				
EOLP-BI1696-9DAIL	Up to 11.3Gbps	1330nm DFB	Industrial	9dB	LC	YES

Note1: For the latest certification information, please check with Eoptolink.

Note2: Standard version

*The product image only for reference purpose.

Product Description

The EOLP-BI1696-9XXX series single mode transceiver is small form factor pluggable module for duplex optical data communications such as 10GBASE-LR/LW defined by IEEE 802.3ae. It is with the SFP+ 20-pin connector to allow hot plug capability.

The EOLP-BI1696-9ADL module is designed for single mode fiber and operates at a nominal wavelength of 1270nm; EOLP-BI1696-9DAL module is designed for single mode fiber and operates at a nominal wavelength of 1330nm. The transmitter section uses a multiple quantum well DFB, which is class 1 laser compliant according to International Safety Standard IEC-60825.

The receiver section uses an integrated InGaAs detector preamplifier (IDP) mounted in an optical header and a limiting post-amplifier IC.

Absolute Maximum Ratings* Note3

Parameter	Symbol	Min.	Max.	Unit
Storage Temperature	T _s	-40	+85	°C
Supply Voltage	V _{cc}	-0.5	3.6	V

*Note3: Exceeding any one of these values may destroy the device permanently.

Recommended Operating Conditions

Parameter	Symbol	Min.	Typical	Max.	Unit
Power Supply Voltage	V _{cc}	3.15	3.3	3.45	V
Power Supply Current	I _{cc}			430	mA
Surge Current	I _{surge}			+30	mA
Operating Case Temperature	T _c	EOLP-BI1696-9XXL	0	70	°C
		EOLP-BI1696-9XXIL	-40	85	°C
Baud Rate		0.6	10.3125	11.3	Gbaud

Performance Specifications – Electrical

Parameter	Symbol	Min.	Typ.	Max	Unit	Notes
Transmitter						
CML Inputs(Differential)	V _{in}	150		1200	mVpp	AC coupled inputs
Input Impedance	Z _{in}	85	100	115	ohms	R _{in} > 100 kohms

(Differential)						@ DC
Tx_DISABLE Input Voltage – High		2		V _{cc} +0.3	V	
Tx_DISABLE Input Voltage – Low		0		0.8	V	
Tx_FAULT Output Voltage – High		2		V _{cc} +0.3	V	I _o = 400μA; Host V _{cc}
Tx_FAULT Output Voltage – Low		0		0.5	V	I _o = -4.0Ma
Receiver						
CML Outputs (Differential)	V _{out}	350		700	mVpp	AC coupled outputs
Output Impedance (Differential)	Z _{out}	85	100	115	ohms	
Rx_LOS Output Voltage – High		2		V _{cc} +0.3	V	I _o = 400μA; Host V _{cc}
Rx_LOS Output Voltage – Low		0		0.8	V	I _o = -4.0Ma
MOD_DEF (2:0)	VoH	2.5			V	With Serial ID
	VoL	0		0.5	V	

Optical Characteristics

(EOLP-BI1696-9ADL, 1270nm DFB & PIN/TIA)

Parameter	Symbol	Min.	Typical	Max.	Unit
Power Budget		9			dB
Data Rate		0.6	10.3125	11.3	Gbps
Transmitter					
Center Wavelength	λ_c	1260	1270	1280	nm
Spectral Width (-20Db)	$\Delta\lambda$			1	nm
Side Mode Suppression Ratio	SMSR	30			dB
Average Output Power*note4	P _{out, AVG}	-5		0	dBm
Extinction Ratio	ER	3.5			dB
Average Power of OFF Transmitter				-30	dBm
Relative Intensity Noise	RIN			-128	dB/Hz
TX Disable Assert Time	t _{off}			10	us
Receiver					
Center Wavelength	λ_c	1320		1340	nm
Sensitivity*note5	P _{IN}			-14	dBm
Receiver Overload	P _{MAX}	0.5			dBm
LOS De-Assert	LOS _D			-18	dBm
LOS Assert	LOS _A	-30			dBm

(EOLP-BI1696-9DAL, 1330nm DFB & PIN/TIA)

Parameter	Symbol	Min.	Typical	Max.	Unit
Power Budget		9			dB
Data Rate		0.6	10.3125	11.3	Gbps
Transmitter					
Center Wavelength	λ_c	1320	1330	1340	nm
Spectral Width (-20Db)	$\Delta\lambda$			1	nm
Side Mode Suppression Ratio	SMSR	30			dB
Average Output Power*note4	$P_{out, AVG}$	-5		0	dBm
Extinction Ratio	ER	3.5			dB
Average Power of OFF Transmitter				-30	dBm
Relative Intensity Noise	RIN			-128	dB/Hz
TX Disable Assert Time	t_{off}			10	us
Receiver					
Center Wavelength	λ_c	1260		1280	nm
Sensitivity*note5	P_{IN}			-14	dBm
Receiver Overload	P_{MAX}	0.5			dBm
LOS De-Assert	LOS_D			-18	dBm
LOS Assert	LOS_A	-30			dBm

*Note4: Output is coupled into a 9/125um SMF.

*Note5: Measured with worst ER, BER less than 1E-12 and PRBS 2³¹-1 at 10.3125Gbps.

SFP+ Transceiver Electrical Pad Layout

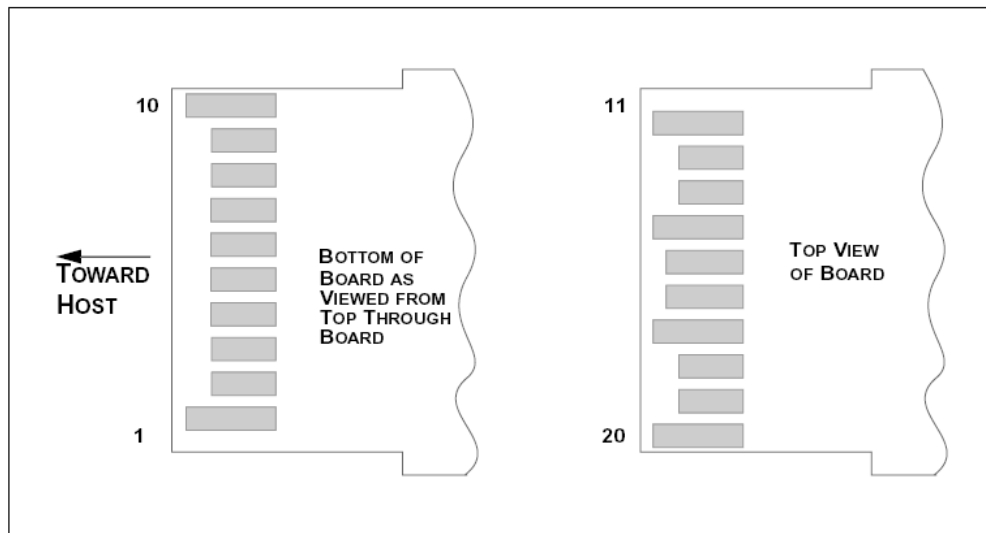

Pin Function Definitions

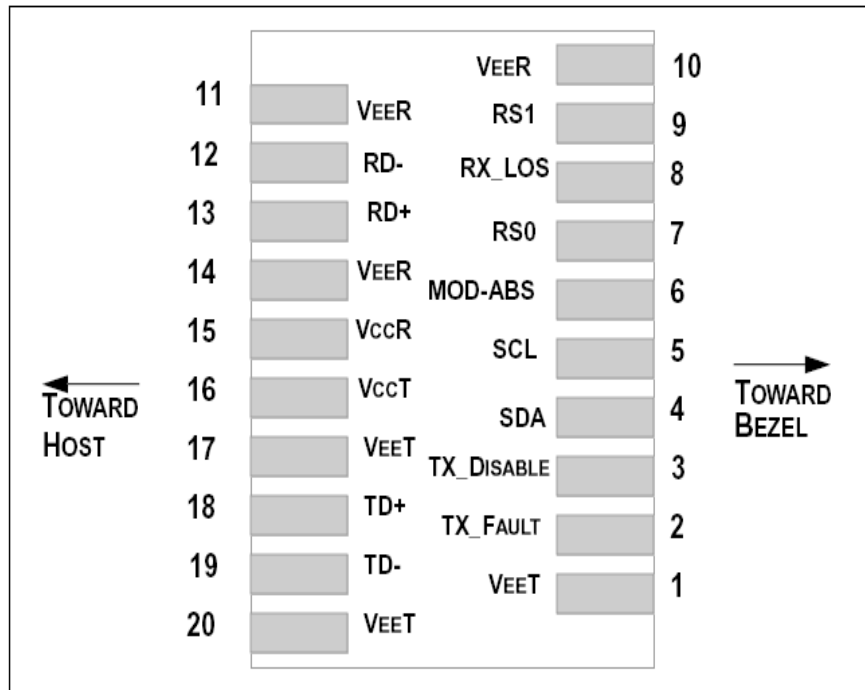

Pin Num.	Name	FUNCTION	Plug Seq.	Notes
1	VeeT	Transmitter Ground	1	Note 5
2	TX Fault	Transmitter Fault Indication	3	Note 1
3	TX Disable	Transmitter Disable	3	Note 2, Module disables on high or open
4	SDA	Module Definition 2	3	2-wire Serial Interface Data Line.
5	SCL	Module Definition 1	3	2-wire Serial Interface Clock.
6	MOD_ABS	Module Definition 0	3	Note 3
7	RS0	RX Rate Select (LVTTL).	3	No Function Implement.
8	LOS	Loss of Signal	3	Note 4
9	RS1	TX Rate Select (LVTTL).	1	No Function Implement.
10	VeeR	Receiver Ground	1	Note 5
11	VeeR	Receiver Ground	1	Note 5
12	RD-	Inv. Received Data Out	3	Note 6
13	RD+	Received Data Out	3	Note 6
14	VeeR	Receiver Ground	1	Note 5
15	VccR	Receiver Power	2	3.3V ± 5%, Note 7
16	VccT	Transmitter Power	2	3.3V ± 5%, Note 7
17	VeeT	Transmitter Ground	1	Note 5

18	TD+	Transmit Data In	3	Note 8
19	TD-	Inv. Transmit Data In	3	Note 8
20	VeeT	Transmitter Ground	1	Note 5

Notes:

1) TX Fault is an open collector/drain output, which should be pulled up with a 4.7K – 10KΩ resistor on the host board. Pull up voltage between 2.0V and $V_{ccT/R}+0.3V$. When high, output indicates a laser fault of some kind. Low indicates normal operation. In the low state, the output will be pulled to $< 0.8V$.

2) TX disable is an input that is used to shut down the transmitter optical output. It is pulled up within the module with a 4.7K – 10 KΩ resistor. Its states are:

Low (0 – 0.8V): Transmitter on

(>0.8, < 2.0V): Undefined

High (2.0 – 3.465V): Transmitter Disabled

Open: Transmitter Disabled

3) Module Absent, connected to VeeT or VeeR in the module.

4) LOS (Loss of Signal) is an open collector/drain output, which should be pulled up with a 4.7K – 10KΩ resistor. Pull up voltage between 2.0V and $V_{ccT/R}+0.3V$. When high, this output indicates the received optical power is below the worst-case receiver sensitivity (as defined by the standard in use). Low indicates normal operation. In the low state, the output will be pulled to $< 0.8V$.

5) The module signal ground contacts, VeeR and VeeT, should be isolated from the module case.

6) RD-/+ : These are the differential receiver outputs. They are AC coupled 100Ω differential lines which should be terminated with 100Ω (differential) at the user SERDES. The AC coupling is done inside the module and is thus not required on the host board. The voltage swing on these lines will be between 350 and 700 Mv differential (175 –350 Mv single ended) when properly terminated.

7) VccR and VccT are the receiver and transmitter power supplies. They are defined as 3.3V $\pm 5\%$ at the SFP+ connector pin. Maximum supply current is 430mA. Recommended host board power supply filtering is shown below. Inductors with DC resistance of less than 1 ohm should be used in order to maintain the required voltage at the SFP+ input pin with 3.3V supply voltage. When the recommended supply-filtering network is used, hot plugging of the SFP+ transceiver module will result in an inrush current of no more than 30Ma greater than the steady state value. VccR and VccT may be internally connected within the SFP+ transceiver module.

8) TD-/+ : These are the differential transmitter inputs. They are AC-coupled, differential lines with 100Ω differential termination inside the module. The AC coupling is done inside the module and is thus not required on the host board. The inputs will accept differential swings of 150 – 1200 Mv (75 – 600Mv single-ended).

EEPROM

The serial interface uses the 2-wire serial CMOS EEPROM protocol defined for the ATMEL AT24C02/04 family of components. When the serial protocol is activated, the host generates the serial clock signal (SCL). The positive edge clocks data into those segments of the EEPROM that are not writing protected within the SFP+ transceiver. The negative edge clocks data from the SFP+ transceiver. The serial data signal (SDA) is bi-directional for serial data transfer. The host uses SDA in conjunction with SCL to mark the start and end of serial protocol activation. The memories are organized as a series of 8-bit data words that can be addressed individually or sequentially.

The Module provides diagnostic information about the present operating conditions. The transceiver generates this diagnostic data by digitization of internal analog signals. Calibration and alarm/warning threshold data is written during device manufacture. Received power monitoring, transmitted power monitoring, bias current monitoring, supply voltage monitoring and temperature monitoring all are implemented. If the module is defined as external calibrated, the diagnostic data are raw A/D values and must be converted to real world units using calibration constants stored in EEPROM locations 56 – 95 at wire serial bus address A2h. The digital diagnostic memory map specific data field define as following .For detail EEPROM information, please refer to the related document of SFF 8472 Rev 10.2.

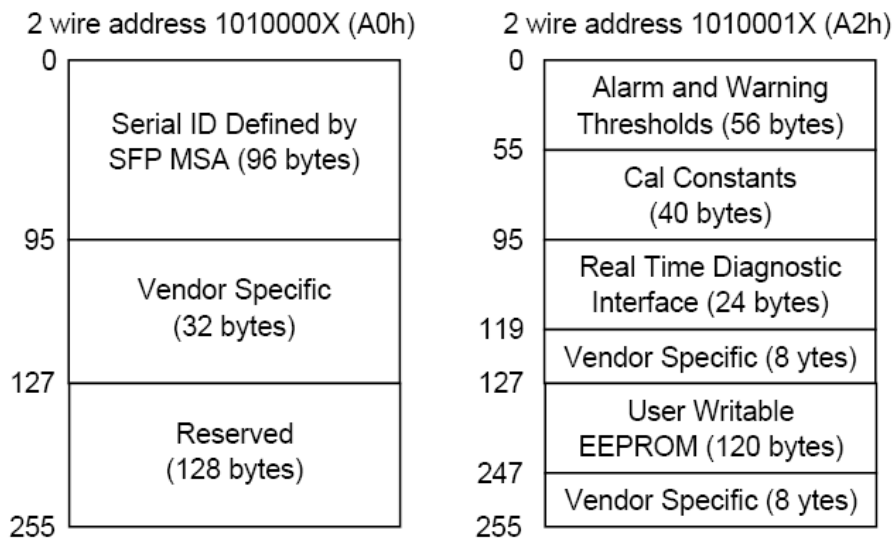

Recommend Circuit Schematic

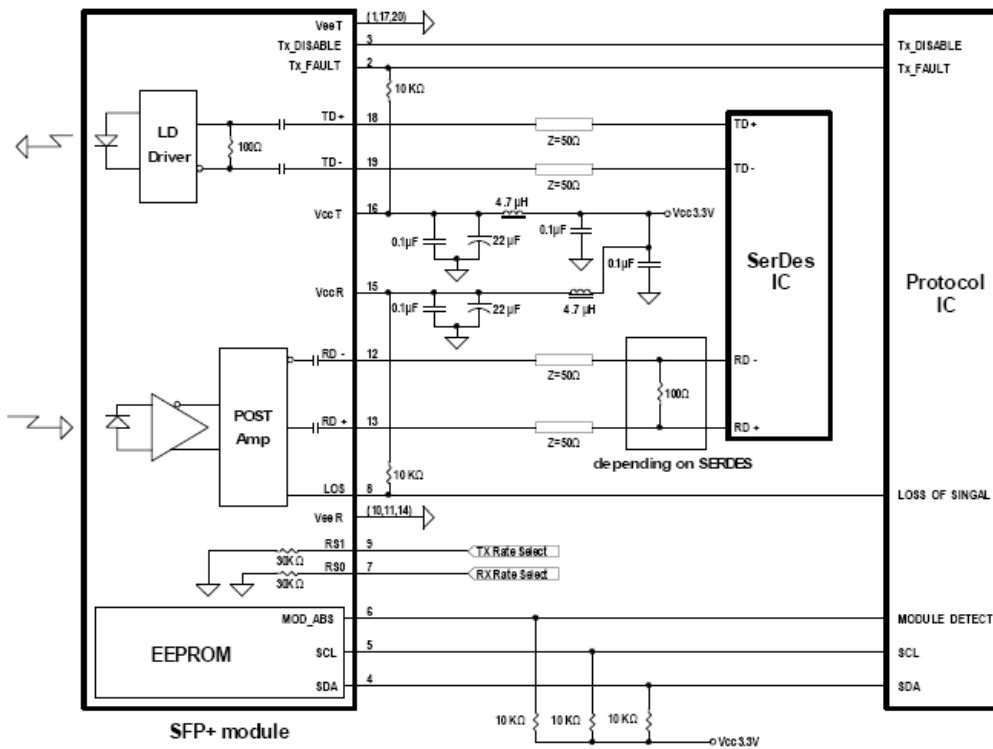

Mechanical Specifications

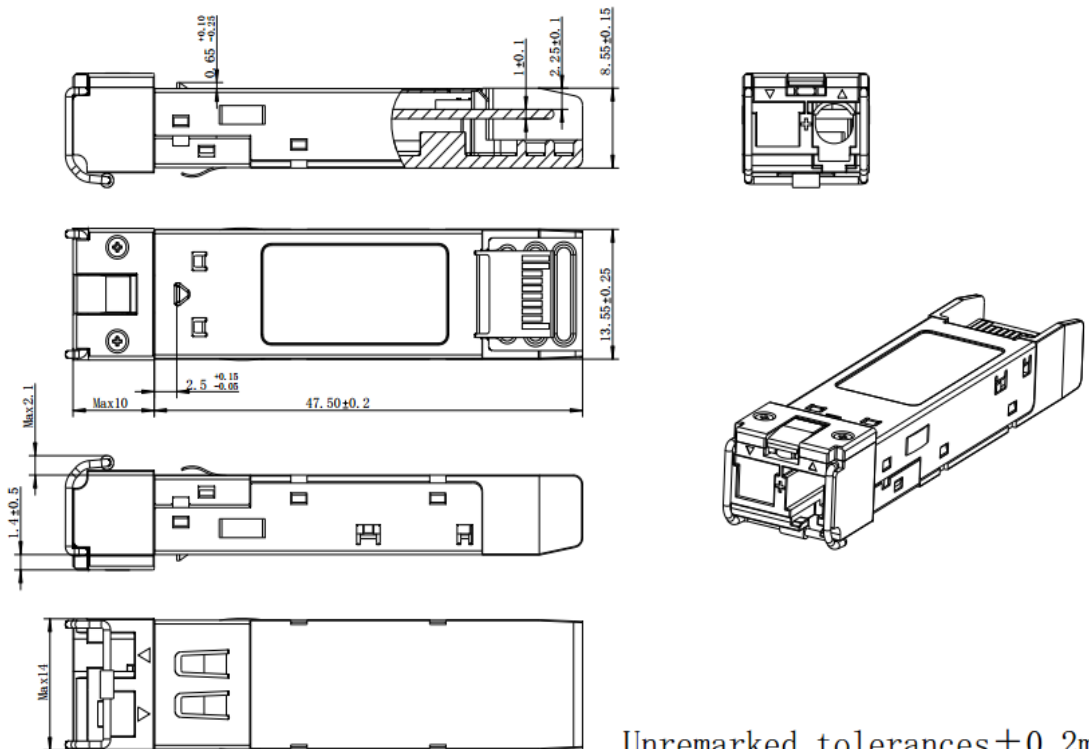

Unremarked tolerances ±0.2mm

*This 2D drawing only for reference, please check with Eoptolink before ordering.

Eye Safety

This single-mode transceiver is a Class 1 laser product. It complies with IEC-60825 and FDA 21 CFR 1040.10 and 1040.11. The transceiver must be operated within the specified temperature and voltage limits. The optical ports of the module shall be terminated with an optical connector or with a dust plug.

Obtaining Document

You can visit our website: <http://www.eoptolink.com>

Or contact Eoptolink Technology Inc., Ltd. Listed at the end of the documentation to get the latest document.

Revision History

Revision	Initiated	Reviewed	Approved	DCN	Release Date
V1.a	Kelly			Released.	Dec 3, 2009
V1.b	Kelly			Update PN & Logo.	May 16, 2011
V1.c	Kelly			Add LC info. In PN.	June 8, 2011
V2.0	Alex/Townie	Kelly		Update part name	Aug 10, 2011
V2.a	Townie	Kelly		Add power dissipation.	Aug 23, 2011
V2.b	Kelly			Update power dissipation.	Sep 6, 2011
V2.c	Angela	Kelly		Update pin definition notes	Jan 31, 2013
V2.d	Angela	Fing/Kelly		Update the data rate range, regulatory compliance and temperature ruange.	Jan 27,2015
V2.e	Angela	Vina		Update the mechanical spec. and picture.	Feb 03,2015
V2.f	Angela	Fing/Kelly/ Vina		Delete the TDP and update the tolerances of 2D drawing.	April 14,2015
V2.g	Elaine	Kelly/Angela/ Marvin/ Torres/ Sky/William/ Chao.Wang		Update the CPRI data rate, RS0/RS1 Pin function definition notes, the regulatory compliance, the picture, 2D drawing and the contact.	Mar 28, 2018
V2.h	Angela	Kelly/ Yiwei.Cheng		Updated the regulatory compliance information.	Dec 18, 2018

Notice:

Eoptolink reserves the right to make changes to or discontinue any optical link product or service identified in this publication, without notice, in order to improve design and/or performance. Applications that are described herein for any of the optical link products are for illustrative purposes only. Eoptolink makes no representation or warranty that such applications will be suitable for the specified use without further testing or modification.

Contact:

Add: No.127 West Wulian Street, Gongxing Town, Shuangliu district, Chengdu City, Sichuan, China.

Tel: (+86) 028-67087999

Fax: (+86) 28-67087979-8010

Postal: 610213

E-mail: sales@eoptolink.com

<http://www.eoptolink.com>

E-O-P-T-O-L-I-N-K