

## EOLX-1596-A

**1550nm XFP Single-Mode for 10GbE/FC/SDH/SONET  
Duplex XFP Transceiver  
RoHS6 Compliant**

### Features

- ◆ Supports 9.95Gb/s to 11.3Gb/s Bit Rates
- ◆ Hot-pluggable XFP Footprint
- ◆ Maximum Link Length up to 100km
- ◆ Temperature-Stabilized EML transmitter
- ◆ Duplex LC Connector
- ◆ Built-in Digital Diagnostic Functions
- ◆ Case Operating Temperature:  
Standard: 0°C to 70°C
- ◆ No external clock required



### Applications

- ◆ OC192/ STM 64
- ◆ 10GBASE-ZR/ZW 10G Ethernet
- ◆ Fiber Channel
- ◆ P1L1-2D2
- ◆ ITU-T G.709

### Ordering Information

Part No.	Data Rate	Laser	Fiber Type	Distance	Optical Interface	Case Temp.
EOLX-1596-A	Up to 11.3Gbps	EML	SMF	100km	LC	0°C~70°C

\*The product image only for reference purpose.

## Regulatory Compliance\*

Product Certificate	Certificate Number	Applicable Standard
TUV	R50135086	EN 60950-1:2006+A11+A1+A12+A2
		EN 60825-1:2014
		EN 60825-2:2004+A1+A2
UL	E317337	UL 60950-1
		CSA C22.2 No. 60950-1-07
EMC CE	AE 50384190 0001	EN 55032:2012
		EN 55032:2015
		EN 55024:2010
		EN 55024:2010+A1
'FCC	WTF14F0514417E	47 CFR PART 15 OCT., 2013
FDA	/	CDRH 1040.10
ROHS	/	2011/65/EU

\*: The above certificate number updated to June 2018, because some certificate will be updated every year, such as FDA and ROHS. For the latest certification information, please check with Eoptolink.

## Product Description

The EOLX-1596-A single mode transceiver is small form factor pluggable module for duplex optical data communications such as 10GBASE-ZR/ZW defined by IEEE 802.3ae. It is with the XFP 30-pin connector to allow hot plug capability.

This module is designed for single mode fiber and operates at a nominal wavelength of 1550 nm. The transmitter section uses a 1550nm EML, which is class 1 laser compliant according to International Safety Standard IEC-60825.

The receiver section uses an integrated InGaAs detector preamplifier (IDP) mounted in an optical header and a limiting post-amplifier IC.

## Absolute Maximum Ratings<sup>\*(note1)</sup>

Parameter	Symbol	Min	Typ	Max	Unit
Maximum Supply Voltage 1	Vcc3	-0.5	-	4.0	V
Maximum Supply Voltage 2	Vcc5	-0.5	-	6.0	V
Storage Temperature	T <sub>s</sub>	-40	-	85	°C

Note1: Exceeding any one of these values may destroy the device permanently.

## Recommended Operating Condition

Parameter	Symbol	Min	Typ	Max	Units
Supply Voltage 1	Vcc3	3.13	3.3	3.45	V
Supply Voltage 2	Vcc5	4.75	5	5.25	V
Case Operating Temperature	T <sub>c</sub> EOLX-1596-A	0	-	70	°C

## Electrical Characteristics

Parameter	Symbol	Min	Typ	Max	Unit
Main Supply Voltage	Vcc5	4.75	-	5.25	V
Supply Voltage #2	Vcc3	3.13	-	3.45	V
Supply Current – Vcc5 supply	Icc5	-	-	370	mA
Supply Current – Vcc3 supply	Icc3	-	-	500	mA
Module Total Power	P	-	-	3.5	W
<b>Transmitter</b>					
Input Differential Impedance*(note2)	Rin	-	100	-	Ω
Differential Data Input Swing	Vin,pp	120	-	820	mV
Transmit Disable Voltage	V <sub>D</sub>	2.0	-	Vcc	V
Transmit Enable Voltage	V <sub>EN</sub>	GND	-	GND+ 0.8	V
Transmit Disable Assert Time		-	-	10	us
<b>Receiver</b>					
Differential Data Output Swing*(note2)	Vout,pp	340	650	850	mV
Rise Time (20 – 80%)	tr	-	-	38	ps
Fall Time (20 – 80%)	tf	-	-	38	ps
LOS Fault*(note3)	V <sub>LOS fault</sub>	Vcc – 0.5	-	VccHOST	V
LOS Normal*(note3)	V <sub>LOS norm</sub>	GND	-	GND+0.5	V

Note2: After internal AC coupling

Note3: Loss of signal is open collector. Logic 0 indicates normal operation; logic 1 indicates no signal detected.

## Optical Characteristics

Parameter	Symbol	Min	Typ	Max	Unit
<b>Transmitter</b>					
Output Power @ 9/125 SMF	P <sub>out</sub>	0	-	+5	dBm
Optical Wavelength	λ <sub>c</sub>	1530	-	1565	nm
Spectral Width (-20dB)	Δλ	-	-	1	nm
Optical Extinction Ratio@10.3Gb/s	ER	9	-	-	dB
Average Launch Power of OFF Transmitter	P <sub>OFF</sub>	-	-	-30	dBm
TX Jitter Generation (Peak-to-Peak)	T <sub>Xj</sub>	-	-	0.1	UI
TX Jitter Generation (RMS)	T <sub>XjRMS</sub>	-	-	0.01	UI
Relative Intensity Noise	RIN	-	-	-130	dB/Hz
Eye Mask		Compliant with ITU-T G.691			
<b>Receiver</b>					
Receiver Sensitivity@ 9.95Gb/s*(note4)	P <sub>min</sub>	-	-	-25	dBm
Receiver Sensitivity @ 10.3Gb/s*(note4)	P <sub>min</sub>	-	-	-25	dBm
Overload Power	P <sub>max</sub>	-7	-	-	dBm
Optical Center Wavelength	λ <sub>c</sub>	1270	1550	1600	nm
Receiver Reflectance	R <sub>f</sub>	-	-	-27	dB
LOS De-Assert	LOS <sub>DEASS</sub>	-	-	-26	dBm

LOS Assert	LOS <sub>ASS</sub>	-38	-	-	dBm
LOS Hysteresis		0.5	-	-	dB

Note4: Back to back, measured with a PRBS  $2^{31}-1$  test pattern and ER=9dB, BER  $1 \times 10^{-12}$ .

## Pin Descriptions

Pin	Symbol	Name/Description
1	GND	Module Ground
2	VEE5	Optional -5.2 Power Supply – Not required
3	Mod-Desel	Module De-select: When held low allows the module to respond to 2-wire serial interface commands
4	Interrupt	Interrupt (bar): Indicates presence of an important condition which can be read over the serial 2-wire interface
5	TX_DIS	Transmitter Disable: Transmitter laser source turned off
6	VCC5	+5 Power Supply
7	GND	Module Ground
8	VCC3	+3.3V Power Supply
9	VCC3	+3.3V Power Supply
10	SCL	Serial 2-wire interface clock line
11	SDA	Serial 2-wire interface data line
12	Mod_Abs	Module Absent: Indicates module is not present. Grounded in the module.
13	Mod_NR	Module Not Ready;
14	RX_LOS	Receiver Loss of Signal indicator
15	GND	Module Ground
16	GND	Module Ground
17	RD-	Receiver inverted data output
18	RD+	Receiver non-inverted data output
19	GND	Module Ground
20	VCC2	+1.8V Power Supply – Not required
21	P_Down/RST	Power Down: When high, places the module in the low power stand-by mode and on the falling edge of P_Down initiates a module reset
		Reset: The falling edge initiates a complete reset of the module including the 2-wire serial interface, equivalent to a power cycle.
22	VCC2	+1.8V Power Supply – Not required
23	GND	Module Ground
24	RefCLK+	Reference Clock non-inverted input, AC coupled on the host board – Not required
25	RefCLK-	Reference Clock inverted input, AC coupled on the host board – Not required
26	GND	Module Ground
27	GND	Module Ground
28	TD-	Transmitter inverted data input

29	TD+	Transmitter non-inverted data input
30	GND	Module Ground

## Pin arrangement

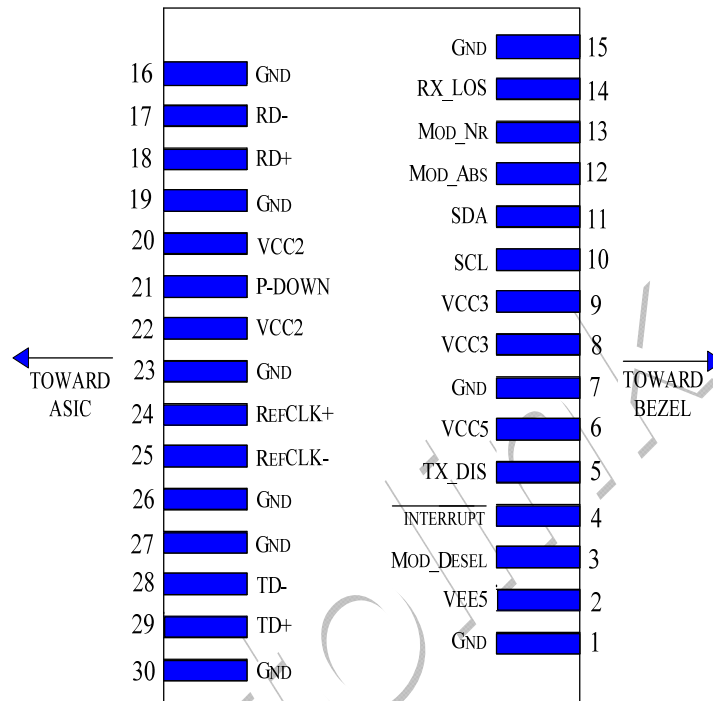

**Pin Numbers and Name**

## Digital Diagnostic Functions

Eoptolink's EOLX-1596-A Small Form Factor 10Gbps (XFP) transceiver is compliant with the current XFP Multi-Source Agreement (MSA) Specification Rev 4.5.

As defined by the XFP MSA, Eoptolink XFP transceivers provide digital diagnostic functions via a 2-wire serial interface, which allows real-time access to the following operating parameters:

- ◆ Transceiver temperature
- ◆ Laser bias current
- ◆ Transmitted optical power
- ◆ Received optical power
- ◆ Transceiver supply voltage

It also provides a sophisticated system of alarm and warning flags, which may be used to alert end-users when particular operating parameters are outside of a factory-set normal range.

The operating and diagnostics information is monitored and reported by a Digital Diagnostics Transceiver Controller inside the transceiver, which is accessed through the 2-wire serial interface. When the serial protocol is activated, the serial clock signal (SCL pin) is generated by the host. The positive edge clocks data into the XFP transceiver into those segments of its memory map that are not write-protected. The negative edge clocks data from the XFP transceiver. The serial data signal (SDA pin) is bi-directional for serial data transfer. The host uses SDA in conjunction with SCL to mark the start and end of serial protocol activation. The

memories are organized as a series of 8-bit data words that can be addressed individually or sequentially. The 2-wire serial interface provides sequential or random access to the 8 bit parameters, addressed from 000h to the maximum address of the memory.

## Recommended Host Board Power Supply Circuit

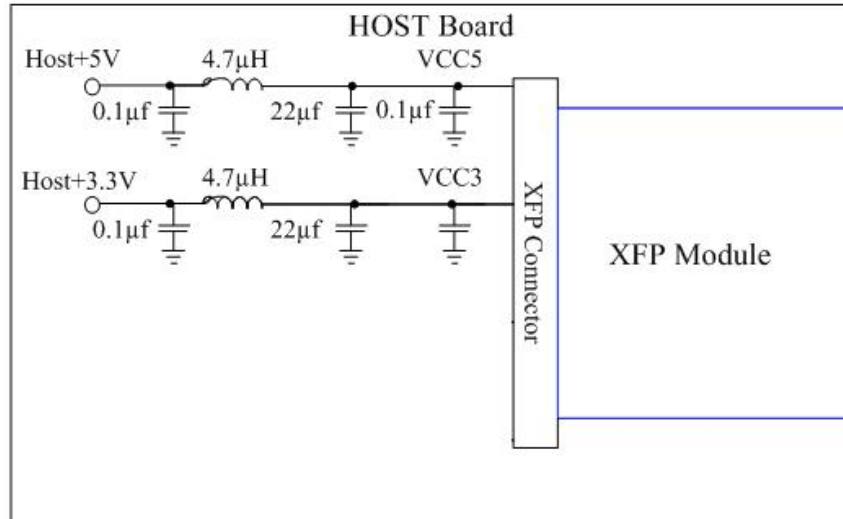

## Recommended High-Speed Interface Circuit

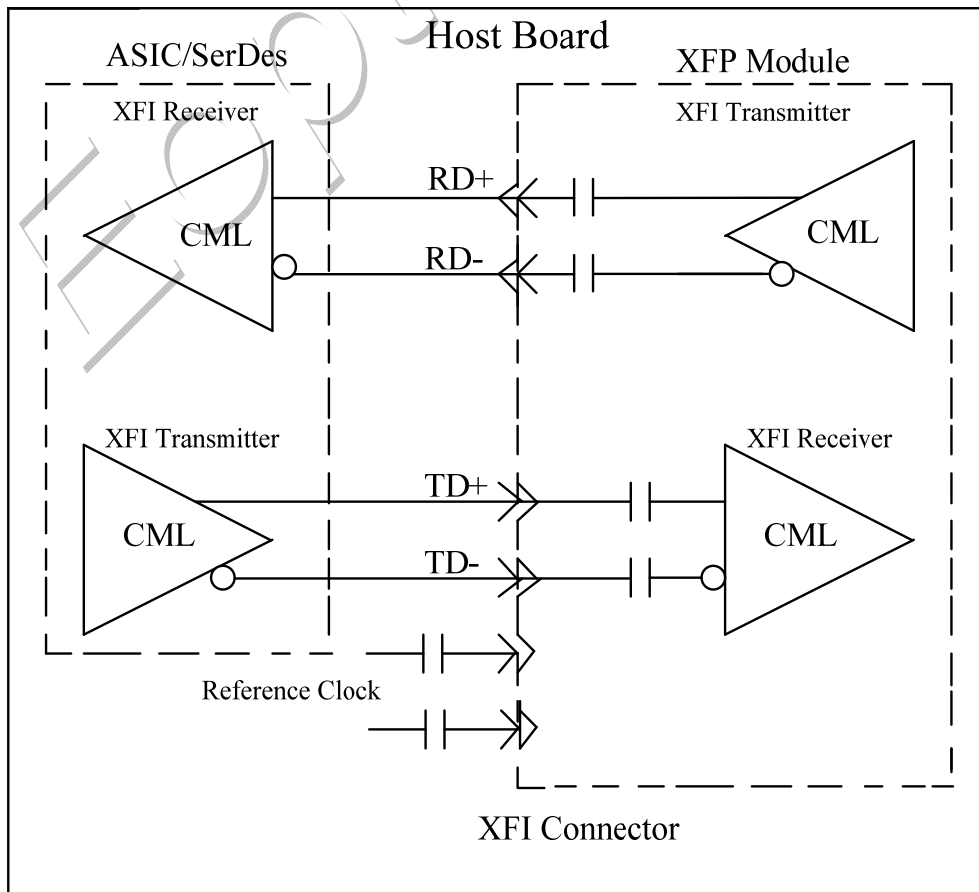

## Mechanical Specifications

Eoptolink's XFP transceivers are compliant with the dimensions defined by the XFP Multi-Sourcing Agreement (MSA).

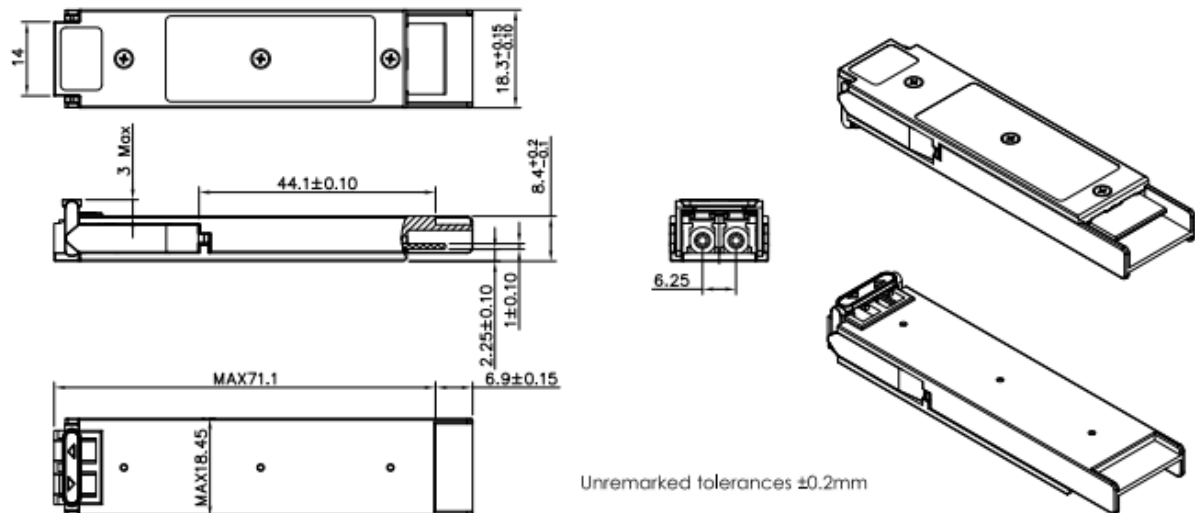

\*This 2D drawing only for reference, please check with Eoptolink before ordering.

## Eye Safety

This single-mode transceiver is a Class 1 laser product. It complies with IEC-60825 and FDA 21 CFR 1040.10 and 1040.11. The transceiver must be operated within the specified temperature and voltage limits. The optical ports of the module shall be terminated with an optical connector or with a dust plug.

## Obtaining Document

You can visit our website: <http://www.eoptolink.com>

Or contact Eoptolink Technology Inc., Ltd. listed at the end of the documentation to get the latest documents.

## Revision History

Revision	Initiated	Reviewed	Approved	Revision History	Release Date
V1.a	Angela	Kelly/Fing/Eason/ Chao.Wang		Standard version released.	September 21, 2018

**Notice:**

Eoptolink reserves the right to make changes to or discontinue any optical link product or service identified in this publication, without notice, in order to improve design and/or performance. Applications that are described herein for any of the optical link products are for illustrative purposes only. Eoptolink makes no representation or warranty that such applications will be suitable for the specified use without further testing or modification.

**Contact:**

Add: No.127 West Wulian Street, Gongxing Town, Shuangliu district, Chengdu City, Sichuan,  
China.

Tel: (+86) 028-67087999

Fax: (+86) 28-67087979-8010

Postal: 610213

E-mail: [sales@eoptolink.com](mailto:sales@eoptolink.com)

<http://www.eoptolink.com>