

EOLX-1696-14X

**CWDM XFP Single-Mode for 10GbE/10GFC/SDH/SONET
Duplex XFP Transceiver
RoHS6 Compliant**

Features

- ◆ Supports 9.95Gb/s to 11.1Gb/s Bit Rates
- ◆ Hot-Pluggable XFP Footprint
- ◆ Compliant with XFP MSA
- ◆ 8-Wavelengths CWDM EML Transmitter
from 1470nm to 1610nm, with Step 20nm
- ◆ 14dB power budget at least
- ◆ Duplex LC Connector
- ◆ Power Dissipation < 3.5W
- ◆ Case Operation Temperature
Standard: 0°C to 70°C
Industrial: -40°C to 85°C
- ◆ 2-Wire Interface for Integrated Digital
Diagnostic Monitoring



Applications

- ◆ SONET / SDH
- ◆ 10GBASE-ER/EW 10G Ethernet
- ◆ 1200-SM-LL-L 10G Fiber Channel
- ◆ 10GE over G.709 at 11.09Gbps
- ◆ OC192 over FEC at 10.709Gbps

Ordering Information

Part No.	Data Rate	Laser	Fiber	Distance	Interface	Temp
EOLX-1696-14X ^{*(note1)}	10G	CWDM EML	SMF	14dB power budget	LC	Standard
EOLX-1696-14XI	10G	CWDM EML	SMF	14dB power budget	LC	Industrial

Note1: X refers to CWDM Wavelength, from 1470nm to 1610nm, X=K, L, ... and R;

*The product image only for reference purpose.

CWDM* Wavelength (0~70°C)

Band	Nomenclature	Wavelength(nm)		
		Min.	Typ.	Max.
S-band Short Wavelength	K	1464	1470	1477.5
	L	1484	1490	1497.5
	M	1504	1510	1517.5
	N	1524	1530	1537.5
C-band Conventional	O	1544	1550	1557.5
L-band Long Wavelength	P	1564	1570	1577.5
	Q	1584	1590	1597.5
	R	1604	1610	1617.5

CWDM*: 8 Wavelengths from 1470nm to 1610nm, each step 20nm.

Regulatory Compliance*

Product Certificate	Certificate Number	Applicable Standard
TUV	R50135086	EN 60950-1:2006+A11+A1+A12+A2
		EN 60825-1:2014
		EN 60825-2:2004+A1+A2
UL	E317337	UL 60950-1
		CSA C22.2 No. 60950-1-07
EMC CE	AE 50384190 0001	EN 55032:2012
		EN 55032:2015
		EN 55024:2010
		EN 55024:2010+A1
FCC	WTF14F0514417E	47 CFR PART 15 OCT., 2013
FDA	/	CDRH 1040.10
ROHS	/	2011/65/EU

*: The above certificate number updated to June 2018, because some certificate will be updated every year, such as FDA and ROHS. For the latest certification information, please check with Eoptolink.

Product Description

The EOLX-1696-14X series optical transceiver is designed for fiber communications application such as 10G Ethernet (10GBASE-ER/EW) and 10G Fiber Channel (1200-SM-LL-L), which fully compliant with the specification of XFP MSA Rev 4.5.

This module is designed for single mode fiber and operates at a nominal wavelength of CWDM wavelength. There are eight center wavelengths available from 1470nm to 1610nm, with each step 20nm. A guaranteed optical link budget of 14dB is offered.

The module is with the XFP 30-pin connector to allow hot plug capability. Only single 3.3V power

supply is needed. The optical output can be disabled by LVTTTL logic high-level input of TX_DIS. Loss of signal (RX_LOS) output is provided to indicate the loss of an input optical signal of receiver. This module provides digital diagnostic functions via a 2-wire serial interface as defined by the XFP MSA Rev 4.5.

Absolute Maximum Ratings

Parameter	Symbol	Min	Max	Unit	
Maximum Supply Voltage	V _{cc}	-0.5	4.0	V	
Storage Temperature	T _s	-40	85	°C	
Case Operating Temperature	T _c	EOLX-1696-14X	0	70	°C
		EOLX-1696-14XI	-40	85	°C

Recommend Operating Condition

Parameter	Symbol	Min	Typical	Max	Units
Operating Temperature	T _c	EOLX-1696-14X	0	70	°C
		EOLX-1696-14XI	-40	85	°C
Supply Voltage 1	V _{cc3}	3.13	3.3	3.45	V
Supply Voltage 2	V _{cc5}	4.75	5	5.25	V
Supply Current-V _{cc3} supply	I _{cc3}			300	mA
Supply Current-V _{cc5} supply	I _{cc5}			750	mA
Module Total Power	P			3.5	W

Electrical Characteristics

Parameter	Symbol	Min	Typical	Max	Unit	Note
Transmitter						
Input Differential Impedance	R _{in}		100		Ω	1
Differential Data Input Swing	V _{in} , pp	180		820	mV	
Transmit Disable Voltage	V _{DIS}	2.0		V _{cc}	V	
Transmit Enable Voltage	V _{EN}	GND		GND+ 0.8	V	
Transmit Disable Assert Time				10	us	
Receiver						
Differential Data Output Swing	V _{out} , pp	340	650	850	mV	
Data Output Rise Time	t _r			38	ps	2
Data Output Fall Time	t _f			38	ps	2
LOS Fault	V _{LOS fault}	V _{cc} - 0.5		V _{cc} HOST	V	3
LOS Normal	V _{LOS norm}	GND		GND+0.5	V	3
Power Supply Rejection	PSR		See Note 4 below			4

Notes:

1. After internal AC coupling.
2. 20 – 80 %.
3. Loss of Signal is open collector to be pulled up with a 4.7k – 10kohm resistor to 3.15 – 3.6V.

Logic 0 indicates normal operation; logic 1 indicates no signal detected.

4. Reference the Section 2.7 of the XFP MSA Rev 4.5.

Optical Characteristics

Parameter	Symbol	Min	Typical	Max	Unit	Note
Transmitter						
Optical Modulation Amplitude	P _{OMA}	-1		+4.4	dBm	1
Output Opt. Pwr: 9/125 SMF	P _{out}	-0.9		+4.0	dBm	
Optical Extinction Ratio	ER	8.2			dB	
Optical Wavelength	λ	$\lambda_c - 6$	λ_c	$\lambda_c + 7.5$	nm	2
-20dB Spectrum Width	$\Delta\lambda$			1	nm	
Side Mode Suppression Ratio	SMSR	30			dB	
Path Penalty	P _p			2.5	dB	
Average Launch Power of OFF Transmitter	P _{OFF}			-30	dBm	
TX Jitter	TX _j	Per 802.3ae requirements				
Relative Intensity Noise	RIN			-128	dB/Hz	
Receiver						
Receiver Sensitivity @ 10.3125Gb/s	P _{min}			-15	dBm	3
Maximum Input Power	P _{max}	+0.5			dBm	
Optical Center Wavelength	λ	1260		1620	nm	
Receiver Reflectance	R _{rf}			-12	dB	
LOS De-Assert	LOS _D			-17	dBm	
LOS Assert	LOS _A	-29			dBm	
LOS Hysteresis		1			dB	

Notes:

1. Output is coupled into a 9/125 μ m SMF.
2. ITU-T G.694.2 CWDM wavelength from 1470nm to 1610nm, each step 20nm.
3. Average received power; BER less than 1E-12 and PRBS 2³¹-1 test pattern.

Pin Descriptions

Pin	Logic	Symbol	Name/Description	Notes
1		GND	Module Ground	1
2		VEE5	Optional -5.2 Power Supply – Not Required	
3	LVTTL-I	Mod-Desel	Module De-select; When held low allows the module to respond to 2-wire serial interface commands	
4	LVTTL-O	/Interrupt	/Interrupt; Indicates presence of an important condition which can be read over the serial 2-wire interface	2

5	LVTTTL-I	TX_DIS	Transmitter Disable; Transmitter laser source turned off	
6		VCC5	+5 Power Supply	
7		GND	Module Ground	1
8		VCC3	+3.3V Power Supply	
9		VCC3	+3.3V Power Supply	
10	LVTTTL-I	SCL	Serial 2-wire interface clock line	2
11	LVTTTL-I/O	SDA	Serial 2-wire interface data line	2
12	LVTTTL-O	Mod_Abs	Module Absent; Indicates module is not present. Grounded in the module.	2
13	LVTTTL-O	Mod_NR	Module Not Ready;	2
14	LVTTTL-O	RX_LOS	Receiver Loss of Signal indicator	2
15		GND	Module Ground	1
16		GND	Module Ground	1
17	CML-O	RD-	Receiver inverted data output	
18	CML-O	RD+	Receiver non-inverted data output	
19		GND	Module Ground	1
20		VCC2	+1.8V Power Supply – Not required	
21	LVTTTL-I	P_Down/RESET	Power Down; When high, places the module in the low power stand-by mode and on the falling edge of P_Down initiates a module reset	
			Reset; The falling edge initiates a complete reset of the module including the 2-wire serial interface, equivalent to a power cycle.	
22		VCC2	+1.8V Power Supply – Not required	
23		GND	Module Ground	1
24	PECL-I	RefCLK+	Reference Clock non-inverted input, AC coupled on the host board – Not required	3
25	PECL-I	RefCLK-	Reference Clock inverted input, AC coupled on the host board – Not required	3
26		GND	Module Ground	1
27		GND	Module Ground	1
28	CML-I	TD-	Transmitter inverted data input	
29	CML-I	TD+	Transmitter non-inverted data input	
30		GND	Module Ground	1

Notes:

1. Module circuit ground is isolated from module chassis ground within the module.
2. Open connect should be pulled up with 4.7k – 10k ohm on host board to a voltage between 3.15V and 3.6V.
3. A Reference Clock input is not required.

Host Board Connector Pin Out

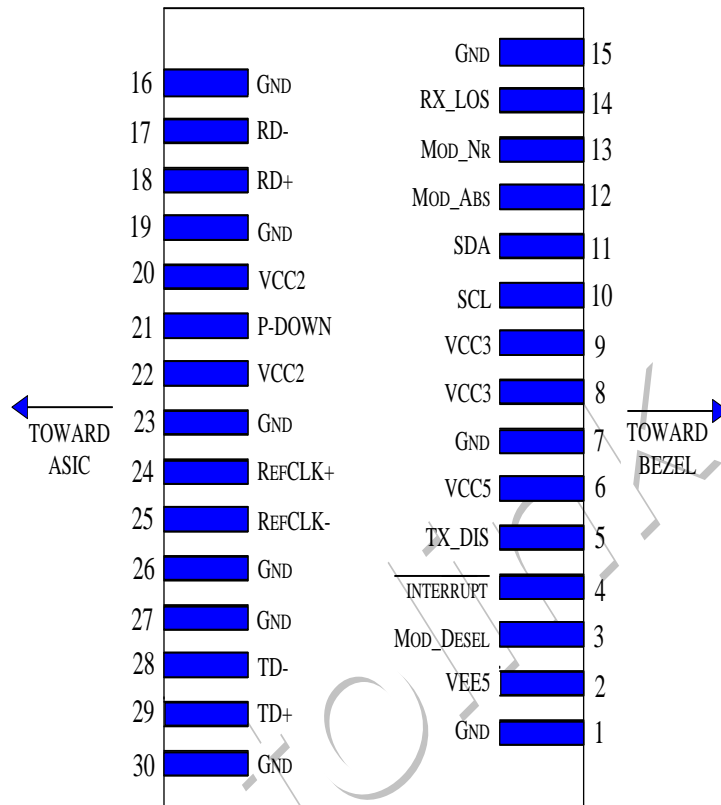

Diagram of Host Board Connector Block Pin Numbers and Name

General Specifications

Parameter	Symbol	Min	Typical	Max	Units	Note
Bit Rate	BR	9.95		11.1	Gb/s	
Bit Error Ratio	BER			10 ⁻¹²		1

Notes:

1. Tested 9.95G with 2³¹ – 1 PRBS pattern.

Digital Diagnostic Functions

Eoptolink's Small Form Factor 10Gbps (XFP) transceiver is compliant with the current XFP Multi-Source Agreement (MSA) Specification Rev 4.5.

As defined by the XFP MSA, Eoptolink XFP transceivers provide digital diagnostic functions via a 2-wire serial interface, which allows real-time access to the following operating parameters:

- ◆ Transceiver temperature
- ◆ Laser bias current
- ◆ Transmitted optical power
- ◆ Received optical power
- ◆ Aux Monitoring

It also provides a sophisticated system of alarm and warning flags, which may be used to alert end-users when particular operating parameters are outside of a factory-set normal range. The operating and diagnostics information is monitored and reported by a Digital Diagnostics Transceiver Controller inside the transceiver, which is accessed through the 2-wire serial interface. The serial data signal (SDA pin) is bi-directional for serial data transfer. The host uses SDA in conjunction with SCL to mark the start and end of serial protocol activation. The memories are organized as a series of 8-bit data words that can be addressed individually or sequentially. The 2-wire serial interface provides sequential or random access to the 8 bit parameters, addressed from 00h to the maximum address of the memory.

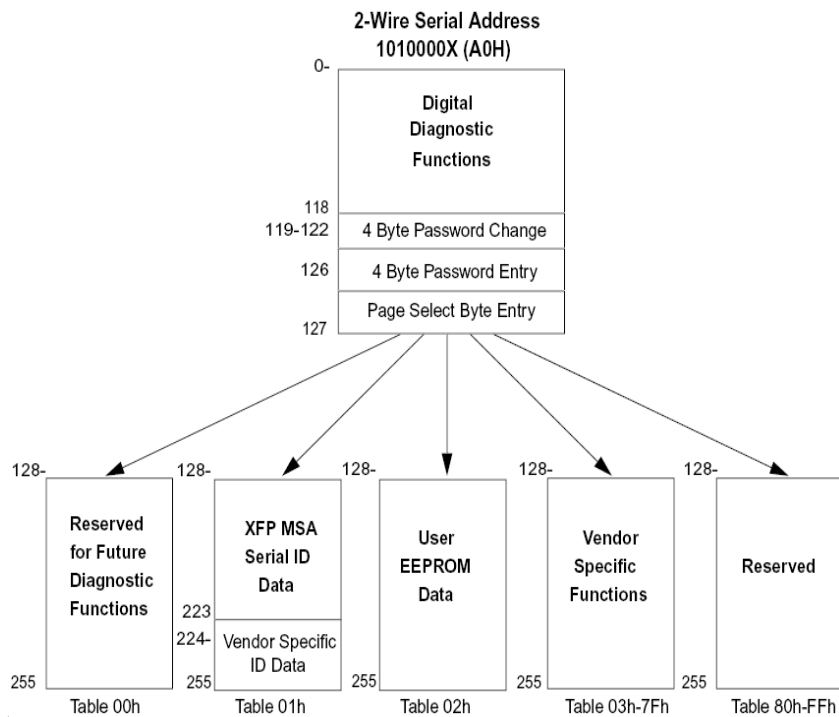

Recommended Host Board Power Supply Circuit

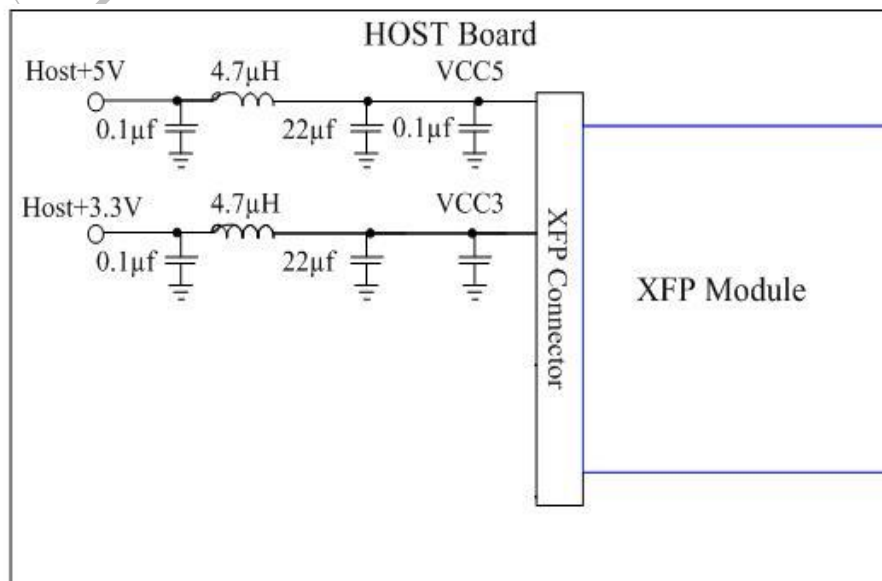

Recommended High-Speed Interface Circuit

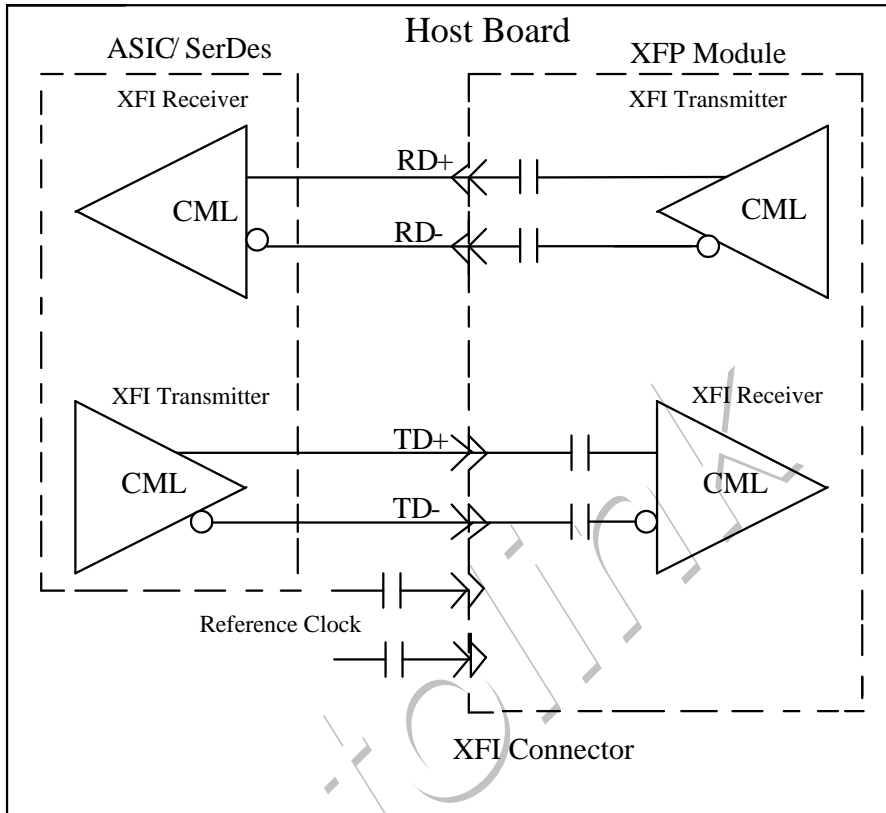

Mechanical Specifications

Eoptolink's XFP transceivers are compliant with the dimensions defined by the XFP Multi-Sourcing Agreement (MSA).

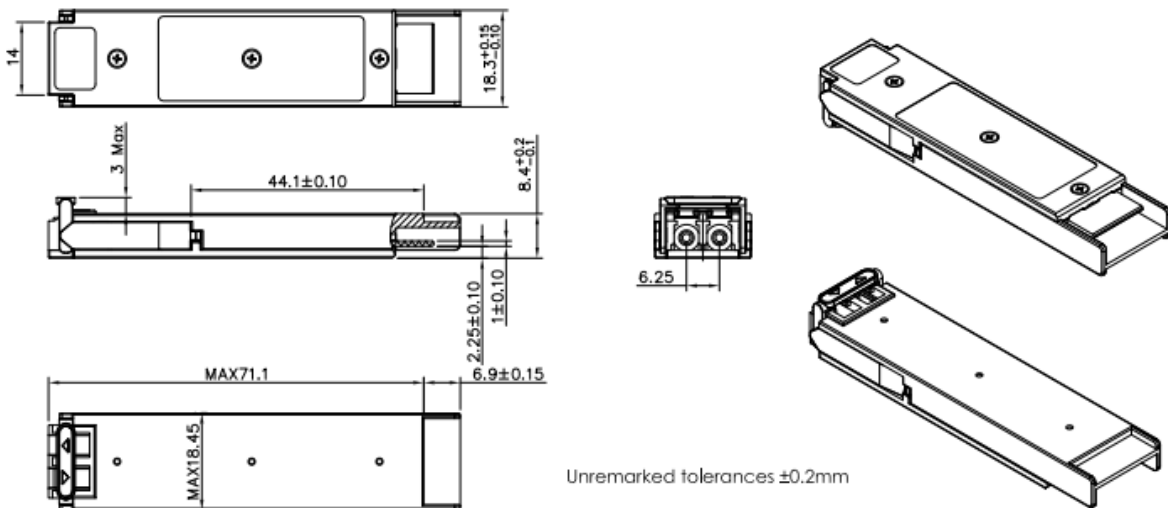

*This 2D drawing only for reference, please check with Eoptolink before ordering.

Eye Safety

This single-mode transceiver is a Class 1 laser product. It complies with IEC-60825 and FDA 21 CFR 1040.10 and 1040.11. The transceiver must be operated within the specified temperature and voltage limits. The optical ports of the module shall be terminated with an optical connector or with a dust plug.

Obtaining Document

You can visit our website: <http://www.eoptolink.com>

Or contact Eoptolink Technology Inc., Ltd. Listed at the end of the documentation to get the latest documents.

Revision History

Revision	Initiated	Reviewed	Approved	Revision History	Release Date
V1.a	Kelly.Cao	Florence.Dai		Released.	Jan 12, 2009
V1.b	Kelly.Cao			Adding the complete CWDM wavelength.	June 24, 2009
V1.c	Kelly.Cao			Revise the component and CWDM wavelength information.	Oct 10, 2009
V1.d	Kelly.Cao			Add the application description.	Nov 6, 2009
V1.e	Kelly.Cao			Correct sensitivity description.	Dec 30, 2009
V1.f	Kelly.Cao			Updating the mechanical graph.	Apr 15, 2010
V1.g	Kelly.Cao			Update LOGO&PN, add EEPROM map.	July 22, 2011
V2.0	Alex/Townie	Kelly.Cao		Update photo and power supply schematic	Aug 10, 2011
V2.a	Kelly			Update Er & supply circuit.	Sep 19, 2011
V2.b	Kelly			Correct Rx max. Wavelength.	Nov 8, 2011

V2.c	Angela	Abby		Update LOS Deassert/Assert.	Sep 17, 2012
V2.d	Abby	Kelly		Update Path Penalty from 2dB to 2.5dB	Dec 18, 2013
V2.e	Elaine	Torres/Fing/ Eason/Chao.Wang/ Kelly/Angela		Add the industrial temperature, update the regulatory compliance and the mechanical specifications.	Aug 14, 2018

Notice:

Eoptolink reserves the right to make changes to or discontinue any optical link product or service identified in this publication, without notice, in order to improve design and/or performance. Applications that are described herein for any of the optical link products are for illustrative purposes only. Eoptolink makes no representation or warranty that such applications will be suitable for the specified use without further testing or modification.

Contact:

Add: No.127 West Wulian Street, Gongxing Town, Shuangliu district, Chengdu City, Sichuan, China.

Tel: (+86) 028-67087999

Fax: (+86) 28-67087979-8010

Postal: 610213

E-mail:sales@eoptolink.com

<http://www.eoptolink.com>