

## EOLX-1696-23XX Series

**XFP DWDM Single-Mode for 10GbE/10GFC/SDH/SONET  
Duplex XFP Transceiver  
RoHS6 Compliant**



### Features

- ◆ Available in all C-Band Wavelength on the 100GHz ITU-T Grid
- ◆ Supports 9.95Gb/s to 11.1Gb/s Bit Rates
- ◆ Hot-pluggable XFP footprint
- ◆ Power Budget 23dB
- ◆ Temperature-Stabilized DWDM Rated EML Transmitter
- ◆ Duplex LC connector
- ◆ Built-in Digital Diagnostic Functions
- ◆ Support Line Side Loopback
- ◆ Support XFI Loopback
- ◆ Auxiliary 1 Monitoring Laser Temperature
- ◆ Auxiliary 2 Monitoring 5V Supply
- ◆ Operating Case Temperature  
Standard: 0°C to 70°C  
Extended: -20°C to 75°C

### Applications

- ◆ 10GBASE-ZR/ZW
- ◆ 1200-SM-LL-L 10G Fiber Channel
- ◆ SONET OC-192
- ◆ SDH STM S-64
- ◆ P1L1-2D2
- ◆ ITU-T G.709

### Ordering Information

Part No.	Data Rate	Laser	Fiber Type	Power Budget	Temp.	Optical Interface
EOLX-1696-23XX*	10G	EML EA	SMF	23dB	Standard	LC
EOLX-1696-23XXE	10G	EML EA	SMF	23dB	Extended	LC

Note1: X refers to page 2-DWDM Wavelength List

\*The product image only for reference purpose.

### DWDM Wavelength List:

Channel	Part NO.	Frequency (THz)	Center Wavelength (nm)
13	EOLX-1696-2313	191.3	1567.13
14	EOLX-1696-2314	191.4	1566.31
15	EOLX-1696-2315	191.5	1565.50
16	EOLX-1696-2326	191.6	1564.68
17	EOLX-1696-2317	191.7	1563.86
18	EOLX-1696-2318	191.8	1563.05
19	EOLX-1696-2319	191.9	1562.23
20	EOLX-1696-2320	192.0	1561.42
21	EOLX-1696-2321	192.1	1560.61
22	EOLX-1696-2322	192.2	1559.79
23	EOLX-1696-2323	192.3	1558.98
24	EOLX-1696-2324	192.4	1558.17
25	EOLX-1696-2325	192.5	1557.36
26	EOLX-1696-2326	192.6	1556.55
27	EOLX-1696-2327	192.7	1555.75
28	EOLX-1696-2328	192.8	1554.94
29	EOLX-1696-2329	192.9	1554.13
30	EOLX-1696-2330	193.0	1553.33
31	EOLX-1696-2331	193.1	1552.52
32	EOLX-1696-2332	193.2	1551.72
33	EOLX-1696-2333	193.3	1550.92
34	EOLX-1696-2334	193.4	1550.12
35	EOLX-1696-2335	193.5	1549.32
36	EOLX-1696-2336	193.6	1548.51
37	EOLX-1696-2337	193.7	1547.72
38	EOLX-1696-2338	193.8	1546.92
39	EOLX-1696-2339	193.9	1546.12
40	EOLX-1696-2340	194.0	1545.32
41	EOLX-1696-2341	194.1	1544.53
42	EOLX-1696-2342	194.2	1543.73
43	EOLX-1696-2343	194.3	1542.94
44	EOLX-1696-2344	194.4	1542.14
45	EOLX-1696-2345	194.5	1541.35
46	EOLX-1696-23-46	194.6	1540.56
47	EOLX-1696-2347	194.7	1539.77
48	EOLX-1696-2348	194.8	1538.98
49	EOLX-1696-2349	194.9	1538.19
50	EOLX-1696-2350	195.0	1537.40

51	EOLX-1696-2351	195.1	1536.61
52	EOLX-1696-2352	195.2	1535.82
53	EOLX-1696-2353	195.3	1535.04
54	EOLX-1696-2354	195.4	1534.25
55	EOLX-1696-2355	195.5	1533.47
56	EOLX-1696-2356	195.6	1532.68
57	EOLX-1696-2357	195.7	1531.90
58	EOLX-1696-2358	195.8	1531.12
59	EOLX-1696-2359	195.9	1530.33
60	EOLX-1696-2360	196.0	1529.55
61	EOLX-1696-2361	196.1	1528.77
62	EOLX-1696-2362	196.2	1527.99

\*Contact EOPTOLINK for the wavelength availability.

## Regulatory Compliance <sup>\*Note2</sup>

Product Certificate	Certificate Number	Applicable Standard
TUV	R50135086	EN 60950-1:2006+A11+A1+A12+A2
		EN 60825-1:2014
		EN 60825-2:2004+A1+A2
UL	E317337	UL 60950-1
		CSA C22.2 No. 60950-1-07
EMC CE	AE 50285865 0001	EN 55022:2010
		EN 55024:2010
FCC	WTF14F0514417E	47 CFR PART 15 OCT., 2013
FDA	/	CDRH 1040.10
ROHS	/	2011/65/EU

Note2: The above certificate number updated to June 2014, because some certificate will be updated every year, such as FCC, FDA and ROHS. For the latest certification information, please check with Eoptolink.

## Absolute Maximum Ratings

Parameter	Symbol	Min	Typ	Max	Unit
Maximum Supply Voltage 1	Vcc3	-0.5		4.0	V
Maximum Supply Voltage 2	Vcc5	-0.5		6.0	V
Storage Temperature	T <sub>s</sub>	-40		85	°C
Case Operating Temperature	T <sub>c</sub>	-20		75	°C
Maximum Input Power	Pm			-8	dBm

## Recommend operating condition

Parameter	Symbol	Min	Typ	Max	Units
Operating Case Temperature	T <sub>c</sub>	-5		70	°C
		-20		75	°C
Supply Voltage 1	Vcc3	3.13	3.3	3.45	V

Supply Voltage 2	Vcc5	4.75	5	5.25	V
------------------	------	------	---	------	---

## Electrical Characteristics

Parameter	Symbol	Min	Typ	Max	Unit
Main Supply Voltage	Vcc5	4.75		5.25	V
Supply Voltage #2	Vcc3	3.13		3.45	V
Supply Current – Vcc5 supply	Icc5			400	mA
Supply Current – Vcc3 supply	Icc3			700	mA
Module Total Power	P		3.5		W
<b>Transmitter</b>					
Input Differential Impedance	Rin		100		Ω
Differential Data Input Swing <sup>*3</sup>	Vin, pp	120		820	mV
Transmit Disable Voltage	VD	2.0		Vcc	V
Transmit Enable Voltage	VEN	GND		GND+ 0.8	V
Transmit Disable Assert Time				10	us
<b>Receiver</b>					
Differential Data Output Swing <sup>*3</sup>	Vout, pp	340	650	850	mV
Rise Time (20~80%)	tr			38	ps
Fall Time (20~80%)	tf			39	ps
LOS Fault <sup>*4</sup>	VLOS fault	Vcc – 0.5		VccHOST	V
LOS Normal <sup>*4</sup>	VLOS norm	GND		GND+0.5	V

Note3. After internal AC coupling.

Note4. Loss of signal is open collector output. Logic 0 indicates normal operation; logic 1 indicates no signal detected.

## Optical Characteristics

Parameter	Symbol	Min	Typ	Max	Unit
<b>Transmitter</b>					
Output Opt. Pwr: 9/125 SMF	Pout	0		+4	dBm
Frequency Range	-	191.3		196.2	THz
Center Wavelength Spacing	λc		100		GHz
Center Frequency Spacing	fc		0.8		nm
Transmitter Center Wavelength End Of Life	λ	X-100	X	X+100	pm
Transmitter Center Wavelength Beginning Of Life	λ	X-25	X	X+25	pm
Optical Extinction Ratio	ER	8.2	9		dB
Dispersion Tolerance	DT			1600	ps/nm
Average Launch Power of OFF transmitter	POFF			-30	dBm

TX Jitter Generation (Peak-to-Peak)	T <sub>xj</sub>			0.1	UI
TX Jitter Generation (RMS)	T <sub>xj</sub> RMS			0.01	UI
<b>Receiver</b>					
Optical Center Wavelength	$\lambda_c$	1520		1600	nm
Receive Sensitivity @ 10.7Gbps	Pin			-23	dBm
Receive Overload @ 10.7Gbps	Pin	-10			dBm
Receiver Reflectance	R <sub>rx</sub>			-27	dB
Dispersion Penalty				2	dB
LOS De-Assert	LOSD			-26	dBm
LOS Assert	LOSA	-38			dBm
LOS Hysteresis		0.5			Db

## Pin Descriptions

Pin	Symbol	Name/Description	Note
1	GND	Module Ground	5
2	VEE5	Optional -5.2 Power Supply – Not required	
3	Mod-Desel	Module De-select; When held low allows the module to respond to 2-wire serial interface commands	
4	Interrupt	Interrupt (bar); Indicates presence of an important condition which can be read over the serial 2-wire interface	6
5	TX_DIS	Transmitter Disable; Transmitter laser source turned off	
6	VCC5	+5 Power Supply	
7	GND	Module Ground	5
8	VCC3	+3.3V Power Supply	
9	VCC3	+3.3V Power Supply	
10	SCL	Serial 2-wire interface clock	6
11	SDA	Serial 2-wire interface data line	6
12	Mod_Abs	Module Absent; Indicates module is not present. Grounded in the module.	6
13	Mod_NR	Module Not Ready;	6
14	RX_LOS	Receiver Loss of Signal indicator	6
15	GND	Module Ground	5
16	GND	Module Ground	5
17	RD-	Receiver inverted data output	
18	RD+	Receiver non-inverted data output	
19	GND	Module Ground	5
20	VCC2	+1.8V Power Supply – Not required	
21	P_Down/RST	Power Down; When high, places the module in the low power stand-by mode and on the falling edge of P_Down initiates a module reset	

		Reset; The falling edge initiates a complete reset of the module including the 2-wire serial interface, equivalent to a power cycle.	
22	VCC2	+1.8V Power Supply – Not required	
23	GND	Module Ground	5
24	RefCLK+	Reference Clock non-inverted input, AC coupled on the host board – Not required	7
25	RefCLK-	Reference Clock inverted input, AC coupled on the host board – Not required	7
26	GND	Module Ground	5
27	GND	Module Ground	5
28	TD-	Transmitter inverted data input	
29	TD+	Transmitter non-inverted data input	
30	GND	Module Ground	5

Note5. Module circuit ground is isolated from module chassis ground within the module.

Note6. Open collector; should be pulled up with 4.7k – 10k ohm on host board to a voltage between 3.15V and 3.6V.

Note7. A Reference Clock input is not required.

## Pin arrangement

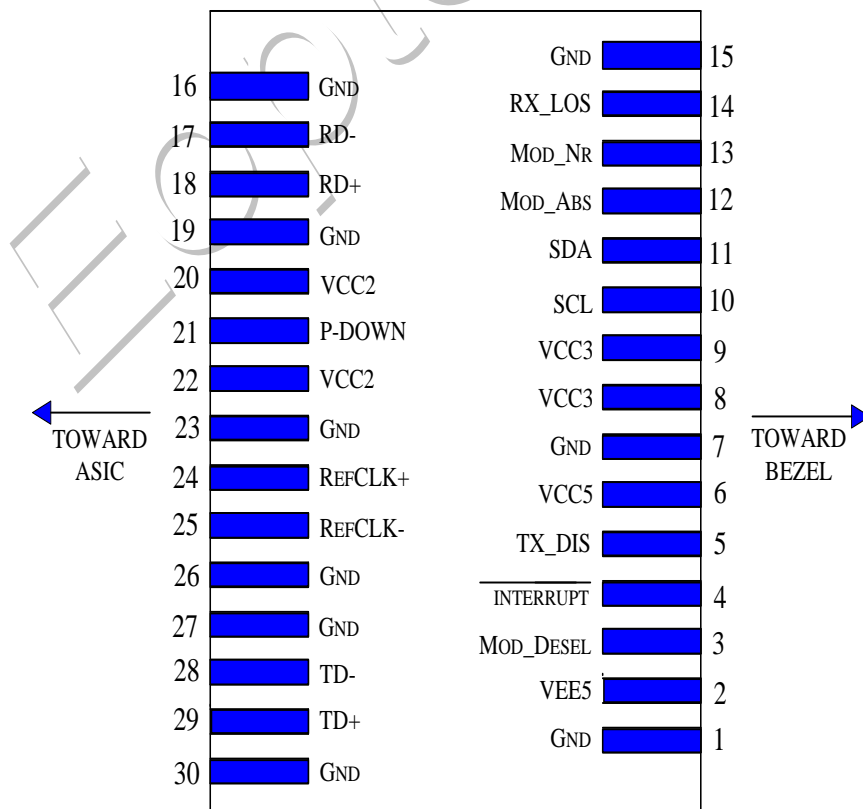

## Pin Numbers and Name

## General Specifications

Parameter	Symbol	Min	Typ	Max	Units	Note
Bit Rate	BR	9.95		11.1	Gb/s	8
Bit Error Ratio	BER			10 <sup>-12</sup>		9

Note8. SONET OC-192 IR-2, OC-192 IR-3, ITU-T G.709, 10GBASE-ZR/ZW + FEC, 10G Fiber Channel

Note9. Tested with a 2<sup>31</sup> – 1 PRBS

## Digital Diagnostic Functions

Eoptolink's EOLX-1696-23XX Small Form Factor 10Gbps (XFP) transceivers are compliant with the current XFP Multi-Source Agreement (MSA) Specification Rev 4.5.

As defined by the XFP MSA, Eoptolink XFP transceivers provide digital diagnostic functions via a 2-wire serial interface, which allows real-time access to the following operating parameters:

- ◆ Transceiver temperature
- ◆ Laser bias current
- ◆ Transmitted optical power
- ◆ Received optical power
- ◆ Transceiver supply voltage
- ◆ Laser temperature

It also provides a sophisticated system of alarm and warning flags, which may be used to alert end-users when particular operating parameters are outside of a factory-set normal range.

The operating and diagnostics information is monitored and reported by a Digital Diagnostics Transceiver Controller inside the transceiver, which is accessed through the 2-wire serial interface. When the serial protocol is activated, the serial clock signal (SCL pin) is generated by the host. The positive edge clocks data into the XFP transceiver into those segments of its memory map that are not write-protected. The negative edge clocks data from the XFP transceiver. The serial data signal (SDA pin) is bi-directional for serial data transfer. The host uses SDA in conjunction with SCL to mark the start and end of serial protocol activation. The memories are organized as a series of 8-bit data words that can be addressed individually or sequentially. The 2-wire serial interface provides sequential or random access to the 8 bit parameters, addressed from 000h to the maximum address of the memory.

**Table 1 Serial ID Memory Contents (Table 01h)**

Addr.	Size (Bytes)	Name of Field	Hex	Description
128	1	Identifier	06	XFP
129	1	Ext. Identifier	90	power consumption < 3.5W, no Ref Colck required
130	1	Connector	07	LC Connector
131~138	8	Transceiver	00 00 00 00 00 00 04 00	Transmitter Code
139	1	Encoding	F0	64B/66B, 8B/10B,SONET Scrambled, NRZ
140	1	BR-Min	63	9.95Gbps
141	1	BR-Max	6F	11.1Gbps
142	1	Length (SMF)km	50	Transceiver transmits 80km.
143	1	Length (E-50µm)	00	
144	1	Length (50µm)	00	
145	1	Length(62.5µm)	00	
146	1	Length (Copper)	00	Not compliant
147	1	Device Tech	76	1550 EML, APD detector
148~163	16	Vendor name	XX XX XX XX XX XX XX XX XX XX XX XX XX XX XX XX XX XX (note)	Vendor name (ASCII)
164	1	CDR Support	FF	FF with 10G CDR
165~167	3	Vendor OUI	00 00 00	
168~183	16	Vendor PN	XX XX XX XX XX XX XX XX XX XX XX XX XX XX XX XX XX XX (note)	
184~185	2	Vendor rev	XX XX XX XX(note)	
186~187	2	Wavelength Tolerance	XX XX(note)	Centre Wavelength
188~189	2	Wavelength Tolerance	00 14	+/- 0.1 nm
190	1	Max Case Temp	46	70deg
191	1	CC_BASE	XX(note)	Check sum of Byte 128 – 190
192~195	4	Power Supply	AF 96 98 00	Max current required by +5V Supply(Ma): 450 , Max current required by +3.3V Supply(Ma): 800
196~211	16	Vendor SN	XX XX XX XX XX XX XX XX XX XX XX XX XX XX XX XX XX XX(note)	
212~219	8	Date Code	XX XX XX XX XX XX XX XX XX(note)	
220	1	Diagnostic	08	No BER Support, Average Power



		Monitoring Type		
221	1	Enhanced Options	60	Optional Soft TX_DISABLE implemented, Optional Soft P_down implemented
222	1	Aux Monitoring	60	Aux A/D input 1: Laser Temperature, Aux A/D input 2: +5V Supply Voltage
223	1	CC_EXT	XX <sup>(note)</sup>	
224~255	32	Vendor Specific	Reserved	Check sum for Extended ID Field.

NOTE: "XX" is referred to be variable.

## Recommended Host Board Power Supply Circuit

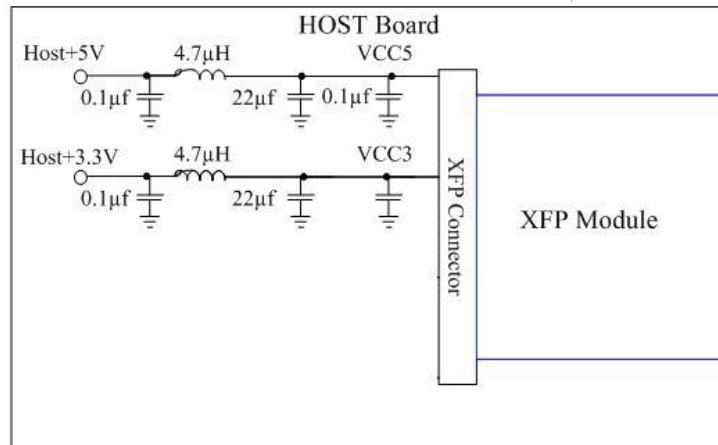

## Recommended High-Speed Interface Circuit

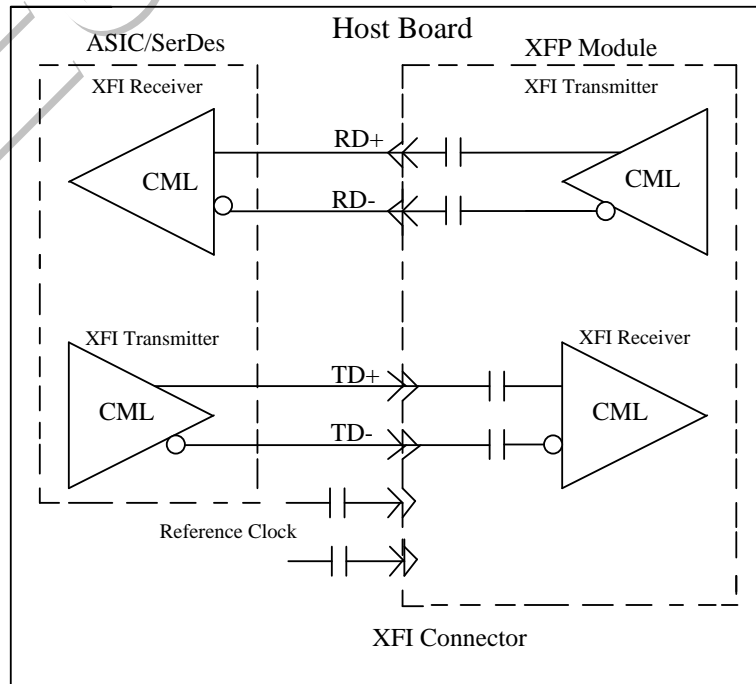

## Mechanical Specifications

Eoptolink's XFP transceivers are compliant with the dimensions defined by the XFP Multi-Sourcing Agreement (MSA).

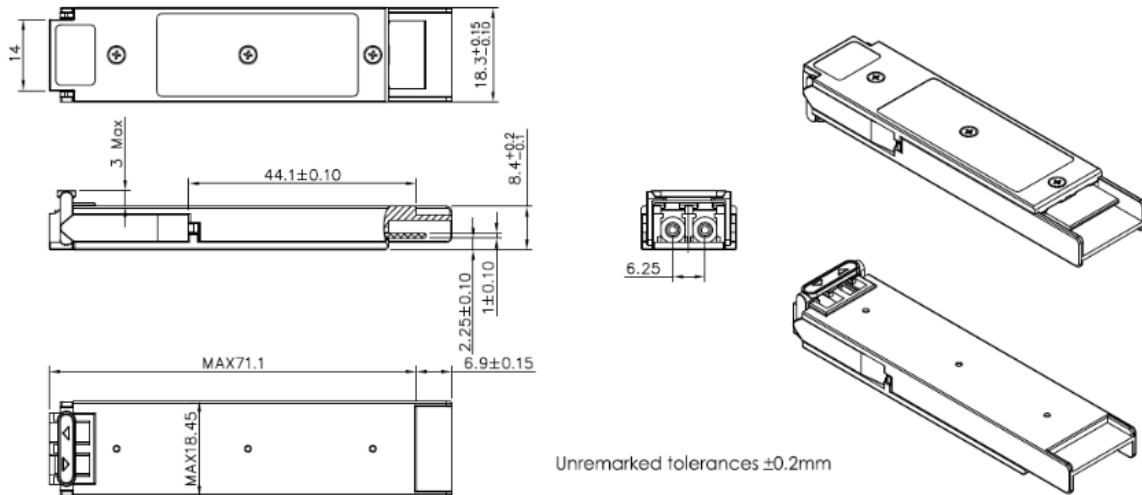

\*This 2D drawing only for reference, please check with Eoptolink before ordering.

## Eye Safety

This single-mode transceiver is a Class 1 laser product. It complies with IEC-60825 and FDA 21 CFR 1040.10 and 1040.11. The transceiver must be operated within the specified temperature and voltage limits. The optical ports of the module shall be terminated with an optical connector or with a dust plug.

## Obtaining Document

You can visit our website:

<http://www.eoptolink.com>

Or contact Eoptolink Technology Inc., Ltd. Listed at the end of the documentation to get the latest documents.

## Revision History

Revision	Initiated	Reviewed	Approved	Revision History	Release Date
V3.a	Kelly			Update feature, budget and PN.	May 27, 2011
V4.0	Alex/Townie	Kelly		Update photo	Aug 10, 2011
V4.a	Kelly			Update supply circuit&sensitivity.	Sep 19, 2011
V4.b	Kelly			Update lcc, overload, Aux2.	Feb 9, 2012

V4.c	Angela	Abby		Update LOS Deassert/Assert.	Sep 17, 2012
V4.d	Angela	Kelly/Fing/ Jp/Eason		Add the channel of 13,14,15,16 and 62. Update the regulatory compliance.	Aug 7,2015
V4.e	Neal	Kelly/ Angela/Fing/ Elaine/ JP/Eason/Torres/ Chao.Wang		Update Temp. output power, 2D Mechanical Specifications,the address and the contact information	Aug 25, 2017

### Notice:

Eoptolink reserves the right to make changes to or discontinue any optical link product or service identified in this publication, without notice, in order to improve design and/or performance. Applications that are described herein for any of the optical link products are for illustrative purposes only. Eoptolink makes no representation or warranty that such applications will be suitable for the specified use without further testing or modification.

### Contact:

Add:No.127 West Wulian Street, Gongxing Town, Shuangliu district, Chengdu City, Sichuan, China.

Tel: (+86) 028-67087999

Fax: (+86) 28-67087979-8010

Postal: 610213

E-mail:sales@eoptolink.com

<http://www.eoptolink.com>