

OLS-1303-02-X Series

Single-Mode 1310nm 100M/155M
 Duplex SFP Transceiver
 RoHS6 Compliant



Features

- ◆ Operating Data Rate up to 155Mbps
- ◆ 2km with 9/125 μ m SMF
- ◆ Single 3.3V Power Supply and TTL Logic Interface
- ◆ Hot-Pluggable SFP Footprint Duplex LC Connector Interface
- ◆ Class 1 FDA and IEC60825-1 Laser Safety Compliant
- ◆ Operating Case Temperature
 - Standard: 0°C~+70°C
 - Industrial:-40°C~+85°C
- ◆ Compliant with MSA SFP Specification
- ◆ Digital Diagnostic Monitor Interface Compatible with SFF-8472

Applications

- ◆ Fast Ethernet
- ◆ OC-3 IR-1 / STM-1 (S-1.1)
- ◆ ATM Switches and Routers
- ◆ Other Optical Links

Ordering Information

Part No.	Data Rate	Fiber	Distance ^{*(note2)}	Interface	Temperature	DDMI
EOLS-1303-02 ^{*(note1)}	155Mbps	SMF	2km	LC	Standard	NO
EOLS-1303-02-I	155Mbps	SMF	2km	LC	Industrial	NO
EOLS-1303-02-D	155Mbps	SMF	2km	LC	Standard	YES
EOLS-1303-02-DI	155Mbps	SMF	2km	LC	Industrial	YES

Note1: Standard version

Note2: 2km with 9/125 μ m SMF

Regulatory Compliance

Feature	Standard	Performance
Electrostatic Discharge (ESD) to the Electrical Pins	MIL-STD-883G Method 3015.7	Class 1C (>1000 V)
Electrostatic Discharge to the Enclosure	EN 55024:1998+A1+A2 IEC-61000-4-2 GR-1089-CORE	Compliant with standards
Electromagnetic Interference (EMI)	FCC Part 15 Class B EN55022:2006 CISPR 22B :2006 VCCI Class B	Compliant with standards Noise frequency range: 30MHz to 6GHz. Good system EMI design practice required to achieve Class B margins. System margins are dependent on customer host board and chassis design.
Immunity	EN 55024:1998+A1+A2 IEC 61000-4-3	Compliant with standards. 1KHz sine-wave, 80% AM, from 80MHz to 1GHz. No effect on transmitter/receiver performance is detectable between these limits.
Laser Eye Safety	FDA 21CFR 1040.10 and 1040.11 EN (IEC) 60825-1:2007 EN (IEC) 60825-2:2004+A1	CDRH compliant and Class I laser product. TüV Certificate No. 50135086
Component Recognition	UL and CUL EN60950-1:2006	UL File E317337 TüV Certificate No. 50135086 (CB scheme)
RoHS6	2002/95/EC 4.1&4.2 2005/747/EC 5&7&13	Compliant with standards ^{*Note3}

Note3: For update of the equipments and strict control of raw materials, EOPTOLINK has the ability to supply the customized products since Jan 1st, 2007, which meet the requirements of RoHS6 (Restrictions on use of certain Hazardous Substances) of European Union.

In light of item 5 in RoHS exemption list of RoHS Directive 2002/95/EC, Item 5: Lead in glass of cathode ray tubes, electronic components and fluorescent tubes.

In light of item 13 in RoHS exemption list of RoHS Directive 2005/747/EC, Item 13: Lead and cadmium in optical and filter glass. The three exemptions are being concerned for Eoptolink's transceivers, because Eoptolink's transceivers use glass, which may contain Pb, for optical components such as lenses, isolators, and other electronic components.

Product Description

The EOLS-1303-02-X series single-mode transceiver is small form factor pluggable module for duplex optical data communications such as Fast Ethernet and OC-3/STM-1 SDH/SONET. It is with the SFP 20-pin connector to allow hot plug capability. This module is designed for single-mode fiber and operates at a nominal wavelength of 1310nm.

The transmitter section uses a multiple quantum well 1310nm laser and is a class 1 laser compliant according to International Safety Standard IEC 60825. The receiver section uses an integrated GaAs detector preamplifier (IDP) mounted in an optical header and a limiting post-amplifier IC.

The EOLS-1303-02-XD series are designed to be compliant with SFF-8472 Multi-source Agreement (MSA).

Absolute Maximum Ratings

Parameter	Symbol	Min.	Max.	Unit
Storage Temperature	TS	-40	+85	°C
Supply Voltage	VCC	-0.5	3.6	V
Operating Relative Humidity		-	95	%

*Exceeding any one of these values may destroy the device immediately.

Recommended Operating Conditions

Parameter	Symbol	Min.	Typical	Max.	Unit
Operating Case Temperature	Tc	EOLS-1303-02-X	0	+70	°C
		EOLS-1303-02-XI	-40	+85	
Power Supply Voltage	Vcc	3.15	3.3	3.45	V
Power Supply Current	Icc			300	mA
Data Rate	OC-3/STM-1		155		Mbps
	FE		100		

Performance Specifications - Electrical

Parameter	Symbol	Min.	Typ.	Max	Unit	Notes
Transmitter						
LVPECL Inputs(Differential)	Vin	400		2000	mVpp	AC coupled inputs*(Note6)
Input Impedance (Differential)	Zin	85	100	115	ohms	Rin > 100 kohms @ DC
TX_Dis	Disable	2		Vcc	V	
	Enable	0		0.8		
TX_FAULT	Fault	2		Vcc+0.3	V	
	Normal	0		0.5		
Receiver						
LVPECL Outputs	Vout	400		2000	mVpp	AC coupled

(Differential)						outputs ^{*(Note6)}
Output Impedance (Differential)	Zout	85	100	115	ohms	
RX_LOS	LOS	2		Vcc+0.3	V	
	Normal	0		0.8	V	
MOD_DEF (0:2)	VoH	2.5			V	With Serial ID
	VoL	0		0.5	V	

Optical and Electrical Characteristics

(1310nm FP and PIN, 2km)

Parameter	Symbol	Min.	Typical	Max.	Unit
9μm Core Diameter SMF	L		2		km
Data Rate			100/155		Mbps
Transmitter					
Center Wavelength	λ_c	1260	1310	1360	nm
Spectral Width (RMS)	$\Delta\lambda$			4	nm
Average Output Power ^{*(Note4)}	Pout	-15		-8	dBm
Extinction Ratio ^{*(Note5)}	ER	8.2			dB
Rise/Fall Time(20%~80%)	tr/tf			2	ns
Output Optical Eye ^{*(Note5)}		IUT-T G.957 Compliant ^{*(Note8)}			
TX_Disable Assert Time	t_off			10	us
Receiver					
Center Wavelength	λ_c	1260		1600	nm
Receiver Sensitivity ^{*(Note7)}	Pmin			-23	dBm
Receiver Overload	Pmax	-8			dBm
LOS De-Assert	LOSD			-24	dBm
LOS Assert	LOSA	-45			dBm
LOS Hysteresis ^{*(Note9)}		0.5			dB

Note4: Output power is power coupled into a 9/125μm single-mode fiber.

Note5: Filtered, measured with a PRBS 2²³-1 test pattern @155Mbps

Note6: LVPECL logic, internally AC coupled.

Note7: Minimum average optical power measured at BER less than 1E-12, with a 2²³-1 PRBS and ER=9 dB.

Note8: Eye Pattern Mask

Note9: LOS Hysteresis

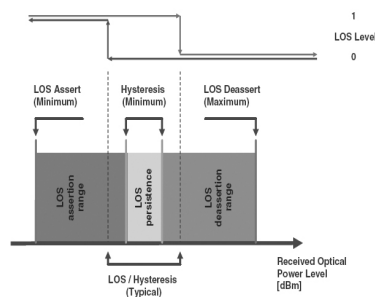
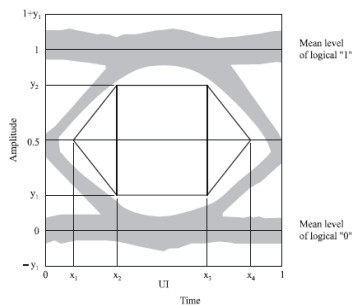

Functional Description of Transceiver

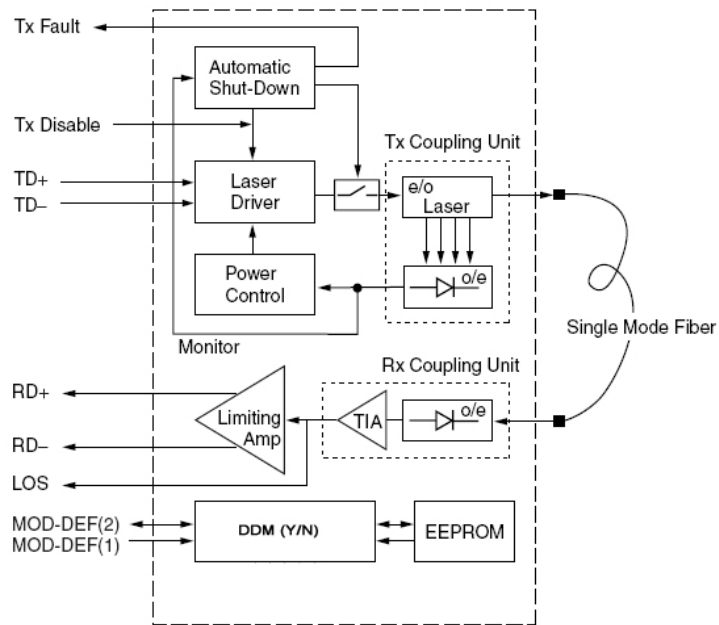

SFP Transceiver Electrical Pad Layout

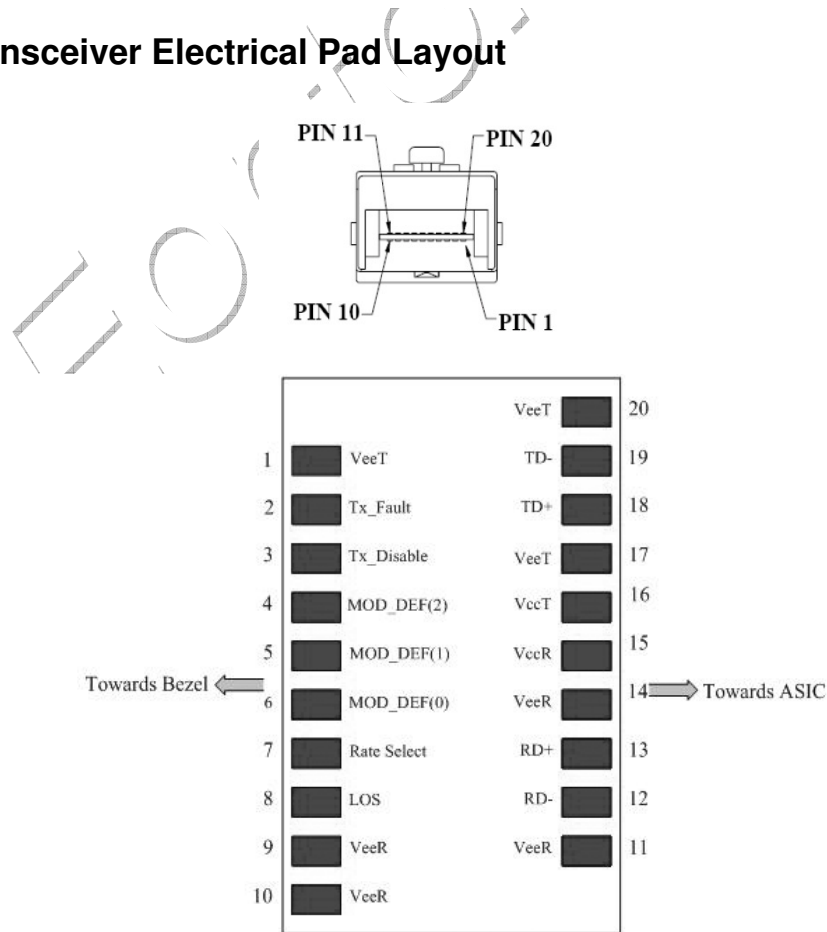

Pin Function Definitions

Pin Num.	Name	Function	Plug Seq.	Notes
1	VeeT	Transmitter Ground	1	5)
2	TX Fault	Transmitter Fault Indication	3	1)
3	TX Disable	Transmitter Disable	3	2) Module disables on high or open
4	MOD-DEF2	Module Definition 2	3	3) 2 wire serial ID interface.
5	MOD-DEF1	Module Definition 1	3	3) 2 wire serial ID interface.
6	MOD-DEF0	Module Definition 0	3	3) Grounded within the module.
7	Rate Select	Not Connect	3	Function not available
8	LOS	Loss of Signal	3	4)
9	VeeR	Receiver Ground	1	5)
10	VeeR	Receiver Ground	1	5)
11	VeeR	Receiver Ground	1	5)
12	RD-	Inv. Received Data Out	3	6)
13	RD+	Received Data Out	3	6)
14	VeeR	Receiver Ground	1	5)
15	VccR	Receiver Power	2	7) 3.3 ± 5%
16	VccT	Transmitter Power	2	7) 3.3 ± 5%
17	VeeT	Transmitter Ground	1	5)
18	TD+	Transmit Data In	3	8)
19	TD-	Inv. Transmit Data In	3	8)
20	VeeT	Transmitter Ground	1	5)

Notes:

1) TX Fault is an open collector/drain output, which should be pulled up with a 4.7K – 10KΩ resistor on the host board. Pull up voltage between 2.0V and VccT, R+0.3V. When high, output indicates a laser fault of some kind. Low indicates normal operation. In the low state, the output will be pulled to < 0.8V.

2) TX disable is an input that is used to shut down the transmitter optical output. It is pulled up within the module with a 4.7 – 10 KΩ resistor. Its states are:

Low (0 – 0.8V): Transmitter on

(>0.8, < 2.0V): Undefined

High (2.0 – 3.465V): Transmitter Disabled

Open: Transmitter Disabled

3) Mod-Def 0,1,2. These are the module definition pins. They should be pulled up with a 4.7K – 10KΩ resistor on the host board. The pull-up voltage shall be VccT or VccR .

Mod-Def 0 is grounded by the module to indicate that the module is present

Mod-Def 1 is the clock line of two wire serial interface for serial ID

Mod-Def 2 is the data line of two wire serial interface for serial ID

4) LOS (Loss of Signal) is an open collector/drain output, which should be pulled up with a 4.7K – 10K Ω resistor. Pull up voltage between 2.0V and VccT, R+0.3V. When high, this output indicates the received optical power is below the worst-case receiver sensitivity (as defined by the standard in use). Low indicates normal operation. In the low state, the output will be pulled to < 0.8V.

5) VeeR and VeeT may be internally connected within the SFP module.

6) RD-/+ : These are the differential receiver outputs. They are AC coupled 100 Ω differential lines which should be terminated with 100 Ω (differential) at the user SERDES. The AC coupling is done inside the module and is thus not required on the host board. The voltage swing on these lines will be between 400 and 2000mV differential (200 –1000mV single ended) when properly terminated.

7) VccR and VccT are the receiver and transmitter power supplies. They are defined as 3.3V \pm 5% at the SFP connector pin. Maximum supply current is 300Ma. Recommended host board power supply filtering is shown below. Inductors with DC resistance of less than 1 ohm should be used in order to maintain the required voltage at the SFP input pin with 3.3V supply voltage. When the recommended supply-filtering network is used, hot plugging of the SFP transceiver module will result in an inrush current of no more than 30Ma greater than the steady state value. VccR and VccT may be internally connected within the SFP transceiver module.

8) TD-/+ : These are the differential transmitter inputs. They are AC-coupled, differential lines with 100 Ω differential termination inside the module. The AC coupling is done inside the module and is thus not required on the host board. The inputs will accept differential swings of 400 – 2000mV (200 – 1000mV single-ended).

EEPROM

The serial interface uses the 2-wire serial CMOS EEPROM protocol defined for the ATMEL AT24C02/04 family of components. When the serial protocol is activated, the host generates the serial clock signal (SCL). The positive edge clocks data into those segments of the EEPROM that are not write protected within the SFP transceiver. The negative edge clocks data from the SFP transceiver. The serial data signal (SDA) is bi-directional for serial data transfer. The host uses SDA in conjunction with SCL to mark the start and end of serial protocol activation. The memories are organized as a series of 8-bit data words that can be addressed individually or sequentially.

The Module provides diagnostic information about the present operating conditions. The transceiver generates this diagnostic data by digitization of internal analog signals. Calibration and alarm/warning threshold data is written during device manufacture. Received power monitoring, transmitted power monitoring, bias current monitoring, supply voltage monitoring and

temperature monitoring all are implemented. If the module is defined as external calibrated, the diagnostic data are raw A/D values and must be converted to real world units using calibration constants stored in EEPROM locations 56 – 95 at wire serial bus address A2h. The digital diagnostic memory map specific data field define as following .For detail EEPROM information, please refer to the related document of SFF 8472 Rev 9.3.

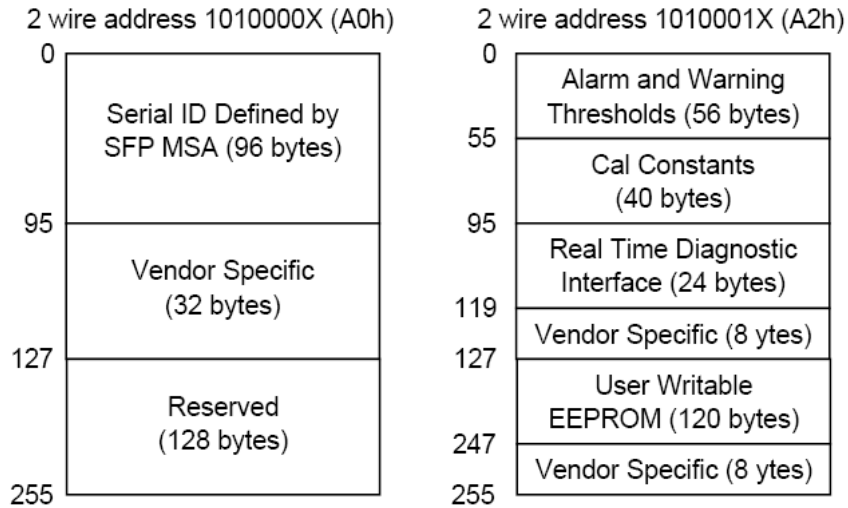

EEPROM Serial ID Memory Contents

Accessing Serial ID Memory uses the 2 wire address 1010000X(A0H). Memory Contents of Serial ID are shown in Table 1.

Table 1 Serial ID Memory Contents

Addr.	Size (Bytes)	Name of Field	Hex	Description
BASE ID FIELDS				
0	1	Identifier	03	SFP
1	1	Ext. Identifier	04	SFP function is defined by serial ID only
2	1	Connector	07	LC Connector
3-10	8	Transceiver	XX ^(Note10)	OC 3, Single mode inter. Or long reach
11	1	Encoding	03	NRZ
12	1	BR, Nominal	02	155Mbps
13	1	Reserved	00	
14	1	Length (9µm)km	02	Transceiver transmit distance
15	1	Length(9µm)100m	14	
16	1	Length (50µm) 10m	00	
17	1	Length(62.5µm)10m	00	
18	1	Length (Copper)	00	Not compliant

19	1	Reserved	00	
20-35	16	Vendor name	XX XX XX XX XX XX XX XX ^(Note10) 20 20 20 20 20 20 20 20	Vendor name (ASCII)
36	1	Reserved	00	
37-39	3	Vendor OUI	XX XX XX ^(Note10)	
40-55	16	Vendor PN	XX XX XX XX XX XX XX XX XX XX XX XX XX XX XX XX ^(Note10)	Vendor part number
56-59	4	Vendor rev	XX XX XX XX ^(Note10)	
60-61	2	Wavelength	05 1E	1310nm
62	1	Reserved	00	
63	1	CC_BASE	Check Sum (Variable)	Check code for Base ID Fields
EXTENDED ID FIELDS				
64-65	2	Options	00 1A	TX_DISABLE, TX_FAULT and Loss of Signal implemented.
66	1	BR,max	00	
67	1	BR,min	00	
68-83	16	Vendor SN	XX XX XX XXXX XX XX XX 20 20 20 20 20 20 20 20 ^(Note10)	Serial Number of transceiver (ASCII). For example "B000822".
84-91	8	Date code	XX XX XX XX XX XX XX XX ^(Note10)	Manufactory date code. For example "080405".
92	1	Diagnostic Monitoring Type	XX ^(Note10)	Digital diagnostic monitoring implemented
93	1	Enhanced Options	XX ^(Note10)	Optional flags
94	1	SFF_8472 Compliance	XX ^(Note10)	01 for diagnostics (Rev9.3 SFF-8472).
95	1	CC_EXT	Check Sum (Variable)	Check sum for Extended ID Field.
VENDOR SPECIFIC ID FIELDS				
96-127	32	Vendor Specific	Read only	Depends on Customer Information
128-255	128	Reserved	Read only	

Note10: The "xx" byte should be filled in according to practical case. For more information, please refer to the related document of SFP Multi-Source Agreement (MSA).

Recommend Circuit Schematic

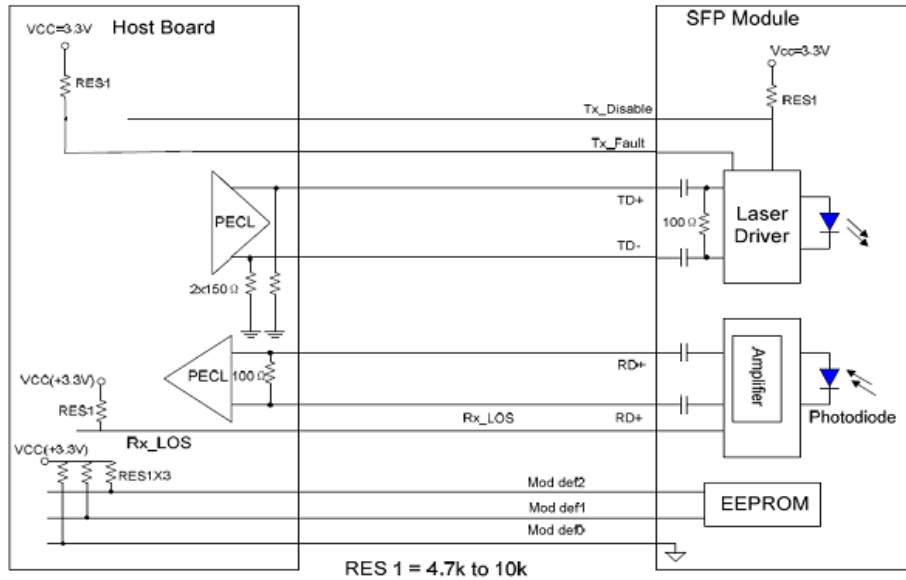

Mechanical Specifications

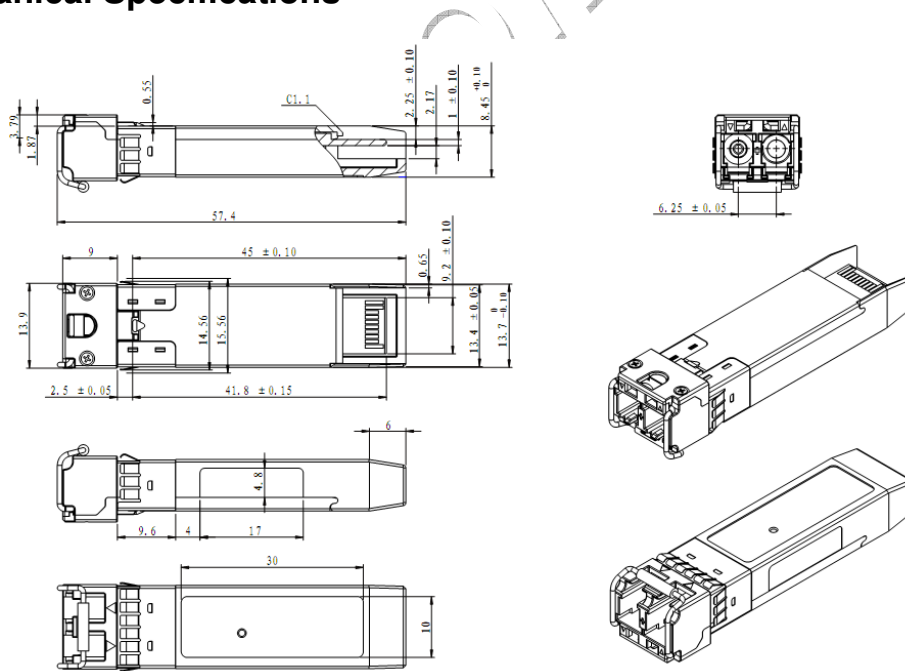

Laser Emission

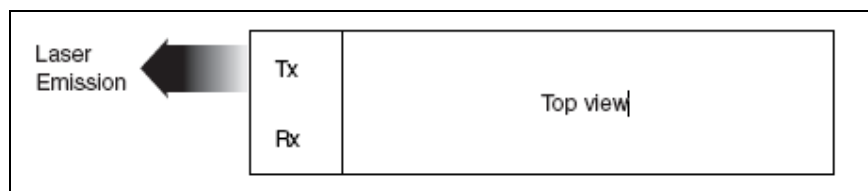

Obtaining Document

You can visit our website:

<http://www.eoptolink.com>

Or contact Eoptolink Technology Inc., Ltd. Listed at the end of the documentation to get the latest document.

Revision History

Revision	Initiated	Reviewed	Approved	Revision History	Release Date
V1.a	Oliver/Arvin /Angela	Lyn/Walt/ Jason/Nygai	Phlio	Released	Sep 12, 2013

Notice:

Eoptolink reserves the right to make changes to or discontinue any optical link product or service identified in this publication, without notice, in order to improve design and/or performance. Applications that are described herein for any of the optical link products are for illustrative purposes only. Eoptolink makes no representation or warranty that such applications will be suitable for the specified use without further testing or modification.

Contact:

Add: Floor 5, Building 2, No. 21 Gaopeng Avenue, High-Tech District, CHENGDU, SICHUAN
610041 P.R. CHINA

Tel: (+86) 028-85122709 ext 816 & 809

Fax: (+86) 028-85121912

Postal: 610041

E-mail: sales@eoptolink.com

<http://www.eoptolink.com>