

ADM1-0026PA

Broadband Distributed Amplifier

DEVICE OVERVIEW

General Description

The ADM1-0026PA is a complete LO driver solution for use with all Marki mixers up to 26.5 GHz. This single-stage packaged GaAs MMIC distributed amplifier integrates all required biasing circuitry. It offers 12 dB typical gain and 21 dBm saturated output power, which is suitable for driving all L, M, I, and H mixers. In saturation it produces a square wave that is optimal for driving a T3 with the highest linearity. The amplifier is operated with a +3V to +7 V positive bias and an optional current reducing negative voltage. While optimized as a mixer LO driver, it is suitable for many applications in test and measurement and laboratory applications.

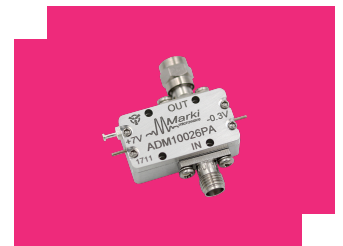

[Download s-parameters here](#)

Features

- Broadband 50 Ω Matching
- Unconditionally Stable
- Optimized for use as a T3 LO buffer amplifier
- Suitable for driving L, M, I, and H diode mixers
- Optional Positive Only Bias Operation
- Integrated Blocking Capacitors and Inductors
- 3rd and 5th Harmonic Generation

Applications

- Test and Measurement Equipment
- Laboratory Applications

Functional Block Diagram

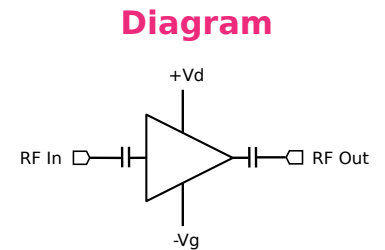

Part Ordering Options

Part Number	Description	Package	Connectors	Green Status	Product Lifecycle	Export Classification
ADM1-0026PA	Broadband Distributed Amplifier	PA	<u>Standard</u>	REACH RoHS	Released	EAR99

Table Of Contents

- **Device Overview**
 - General Description
 - Features
 - Applications
 - Functional Block Diagram
- **Port Configuration and Functions**
 - Port Diagram
 - Port Functions
- **Revision History**
- **Specifications**
 - Absolute Maximum Ratings
 - Package Information
 - Electrical Specifications
 - Typical Performance Plots – Positive Bias Only
 - Typical Performance Plots – Positive and Negative Bias
 - Typical Performance Plots – All Bias
- **Operation**
 - Application Information
- **Mechanical Data**
 - Outline Drawing

Revision History

Revision Code	Revision Date	Comment
-	2020-01-07	Initial Date Release

Port Configuration and Functions

Port Diagram

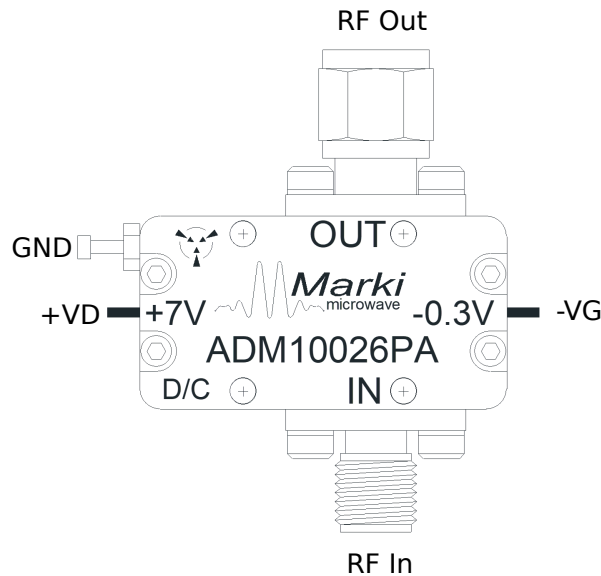

Port Functions

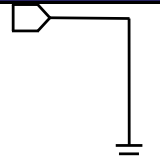
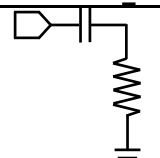
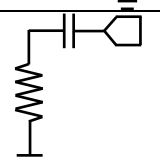
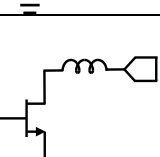
Port	Function	Connector Type	Description	Equivalent Circuit for Package
GND	Ground	-	The housing or outside of the coaxial cables must be connected to a DC/RF ground potential with high thermal and electrical conductivity.	
RF In	RF Input	SMAF	The amplifier's RF Input port is matched to 50 Ω and has built-in DC blocking capacitors.	
RF Out	RF Output	SMAM	The amplifier's RF Output port is matched to 50 Ω and has built-in DC blocking capacitors.	
Vd	Drain Supply Pin	-	Bias supply on Vd should be voltage limited below 9 V and current limited below 250 mA at all times. The operational bias voltage should be between 3 V and 7 V for full gain, efficiency, and linearity. In general linearity and output power will increase marginally with increased voltage from 3 to 7 V.	
	Negative		Bias on this pin is recommended. Application of a negative bias can reduce the current draw from the positive supply, slightly improve small signal gain at higher frequencies, significantly improve even order harmonic suppression, and improve nonlinear	

Specifications

Absolute Maximum Ratings

Parameter	Maximum Rating	Unit
Maximum Operating Temperature	85	°C
Maximum Storage Temperature	150	°C
Minimum Operating Temperature	-55	°C
Minimum Storage Temperature	-65	°C
Negative Bias Current	0.5	mA
Negative Bias Voltage	-2	V
Positive Bias Current	280	mA
Positive Bias Voltage	9	V
Power Dissipation	2.25	W
RF Input Power	15	dBm

Package Information

Parameter	Details	Rating
ESD	< 250 Volts	HBM Class 0
Dimensions	-	28.45 x 14.99 mm

Electrical Specifications

Specifications guaranteed from -55 to +85°C, measured in a 50-Ohm system.

Parameter	Test Conditions	Minimum Frequency (GHz)	Maximum Frequency (GHz)	Min	Typ	Max	Unit
Small Signal Gain	-	0.005	26.5	-	12	-	dB
Noise Figure	-	0.005	26.5	-	4	-	dB
Saturated Output Power	With Negative Bias	0.005	26.5	-	20	-	dBm
Output IP3	-	0.005	26.5	-	25	-	dBm
Input Return Loss	-	0.005	26.5	-	13	-	dB
Output Return Loss	-	0.005	26.5	-	17	-	dB
Bias Requirements	Vd: +3.0 to +7.0 / Vg: -0.2 to -0.3 Volts	0.005	26.5	-	165	250	mA
Bias Requirements	Vd: +3.0 to +7.0 / Vg: 0 Volts	0.005	26.5	-	250	280	mA
Input for Saturated Output	-	0.005	26.5	5	10	15	dBm
Output 1 dB Compression	-	0.005	26.5	-	17	-	dBm

Typical Performance Plots - Positive Bias Only

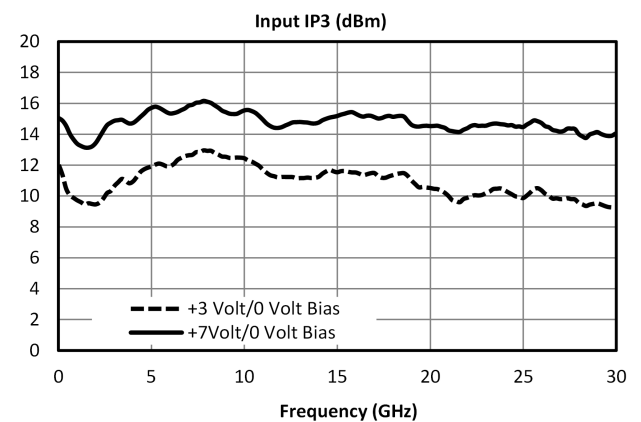
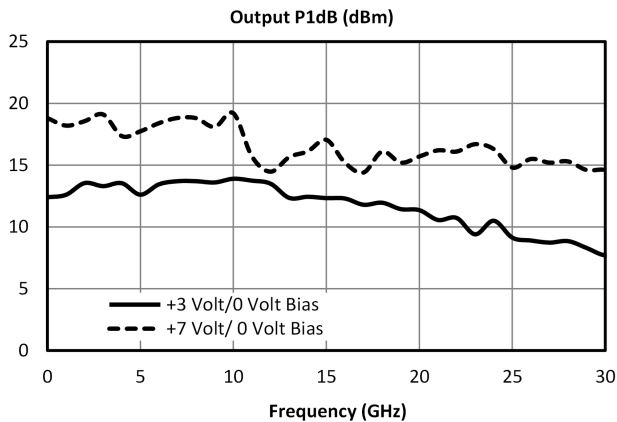
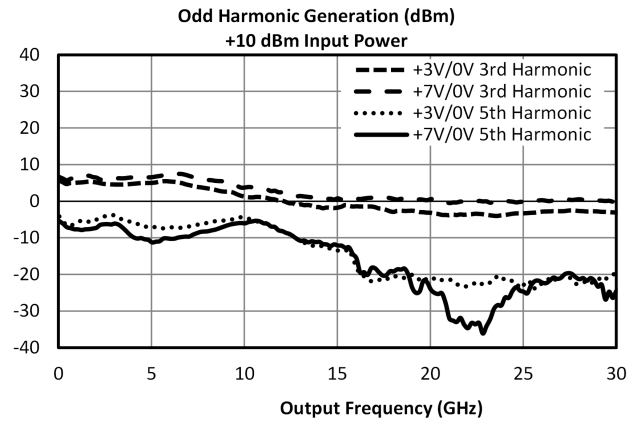
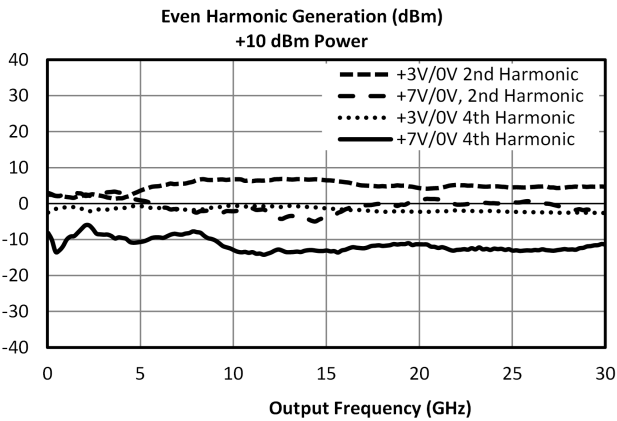
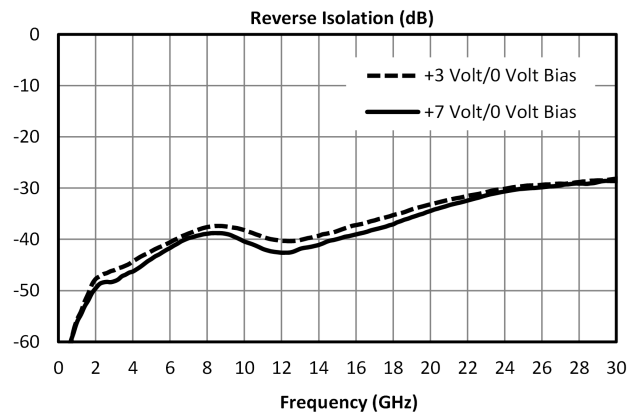
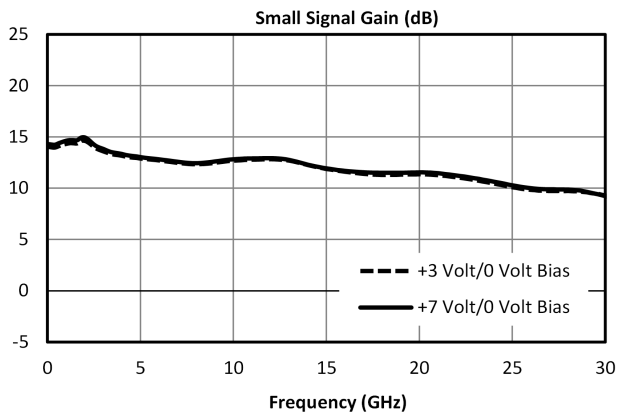
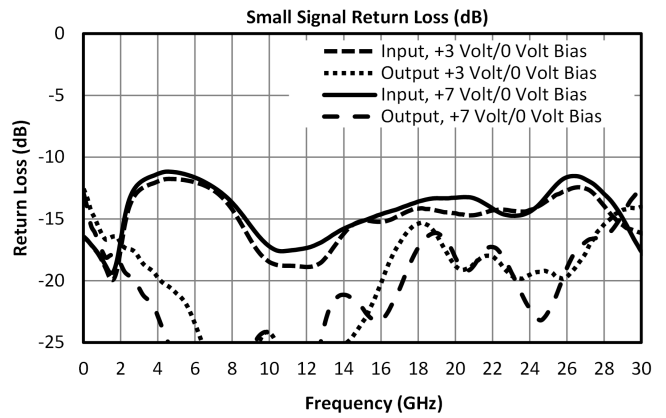
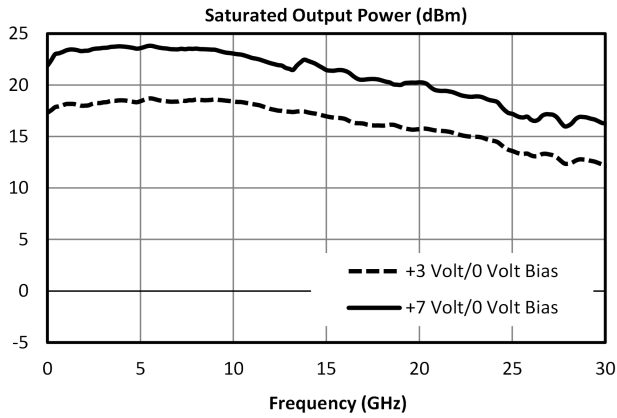

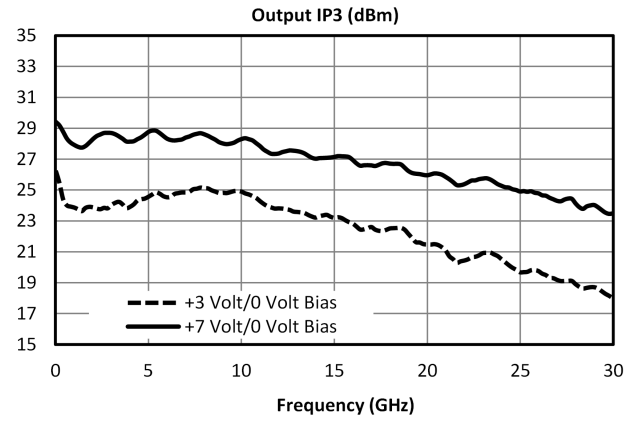
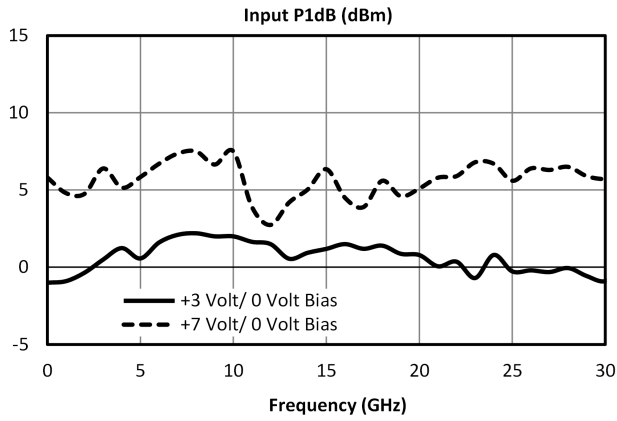

Typical Performance Plots - Positive and Negative Bias

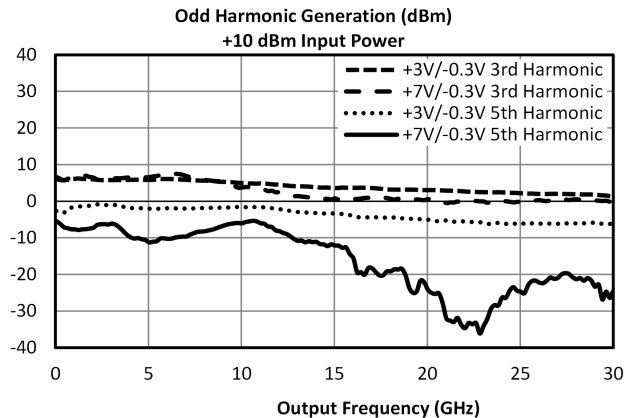
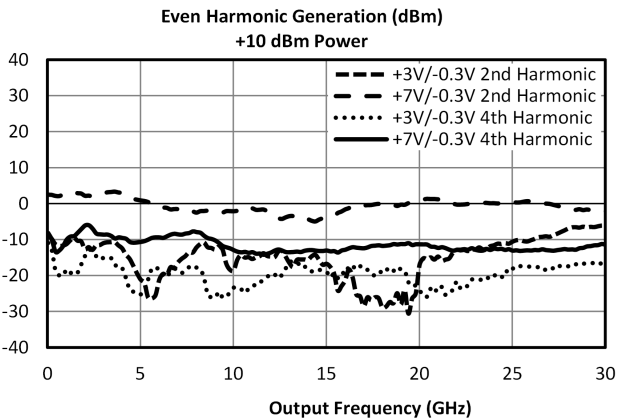
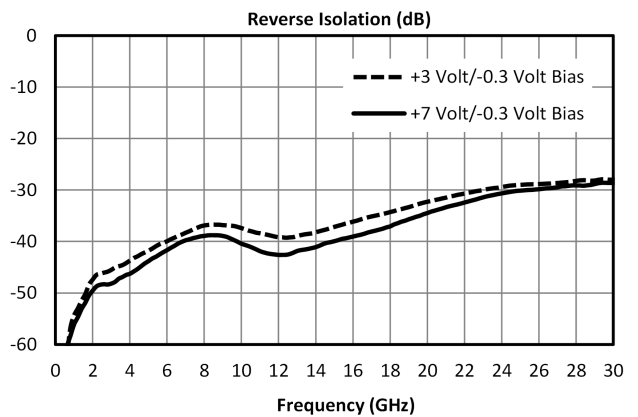
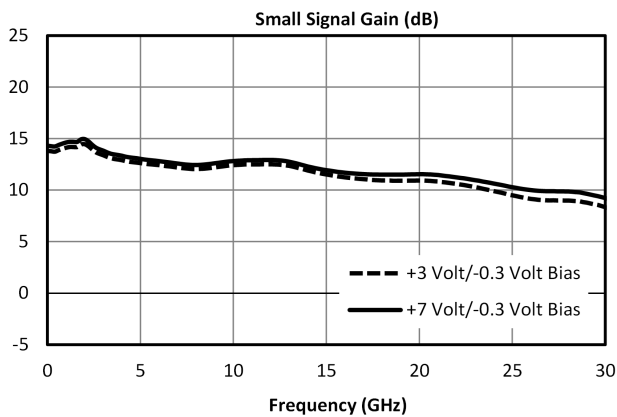
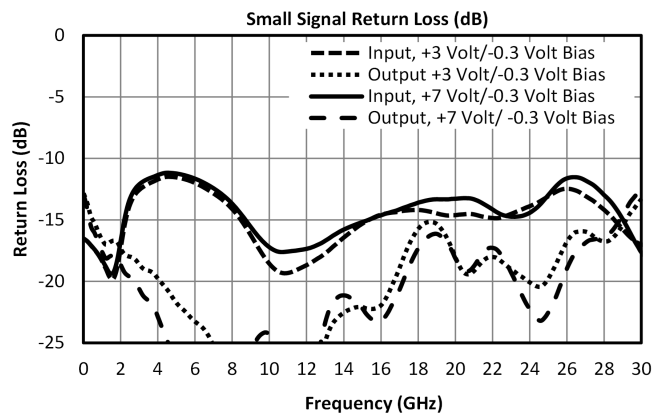
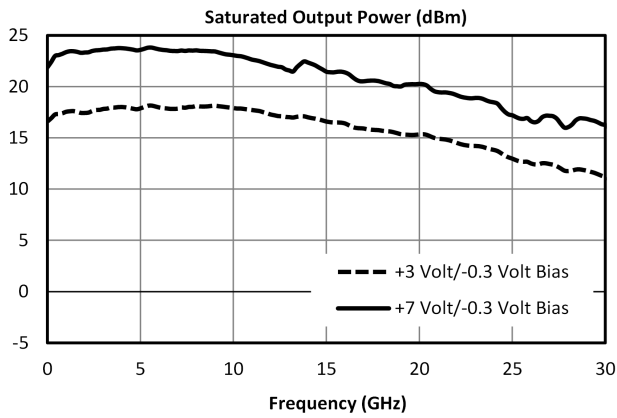

ADM1-0026PA

Broadband Distributed Amplifier

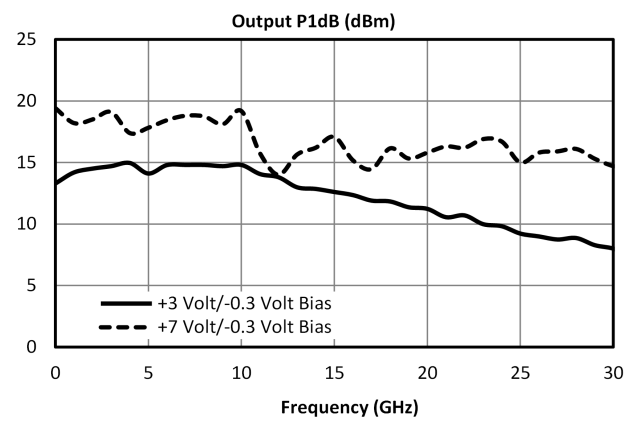
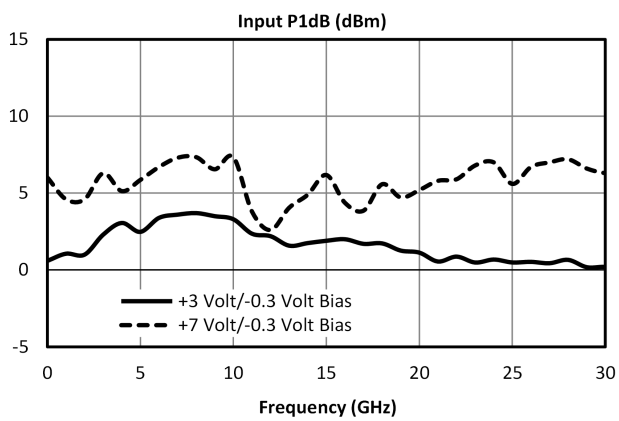
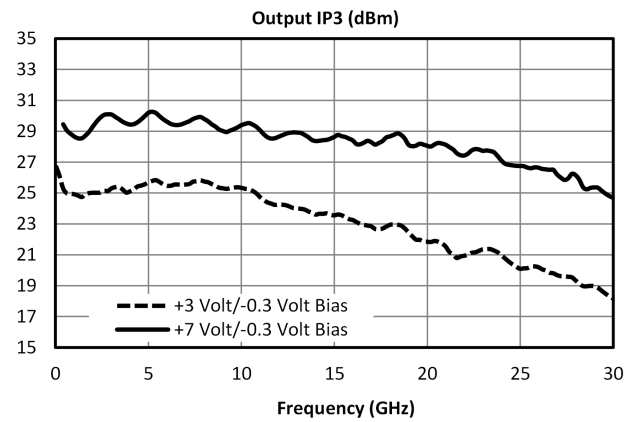
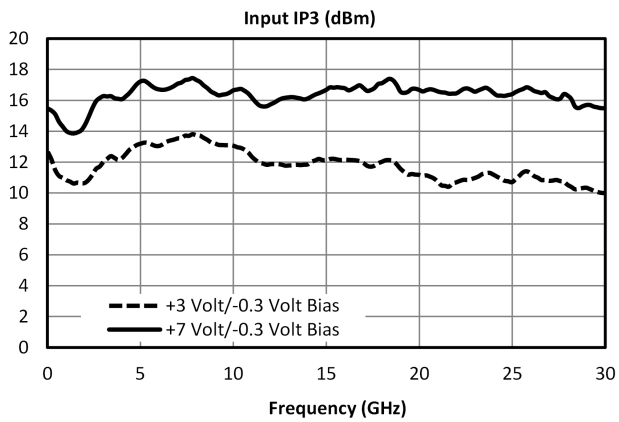

Typical Performance Plots - All Bias

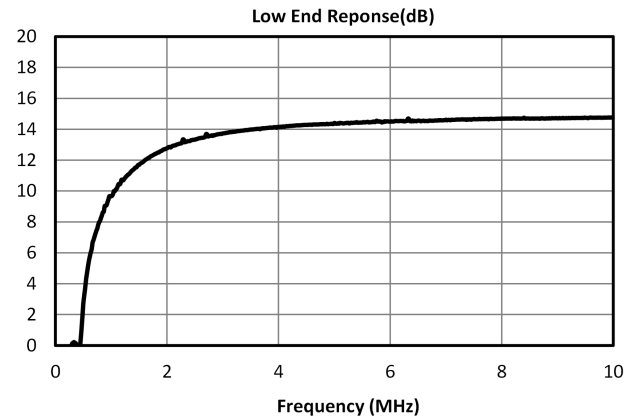
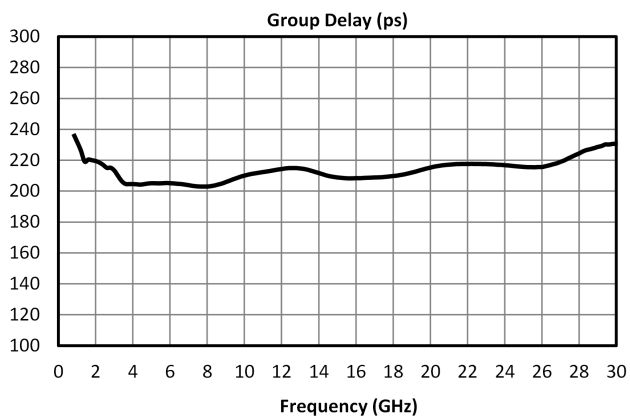
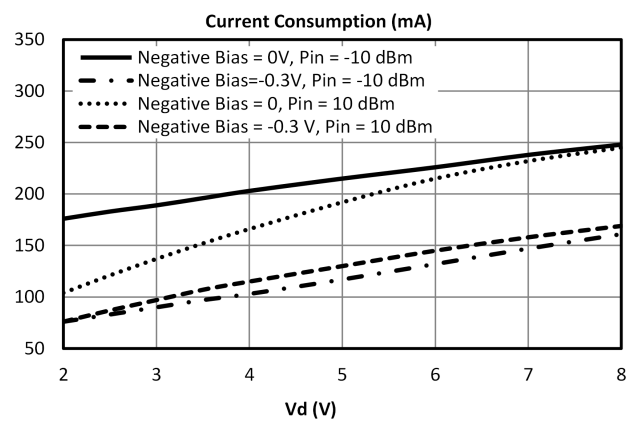
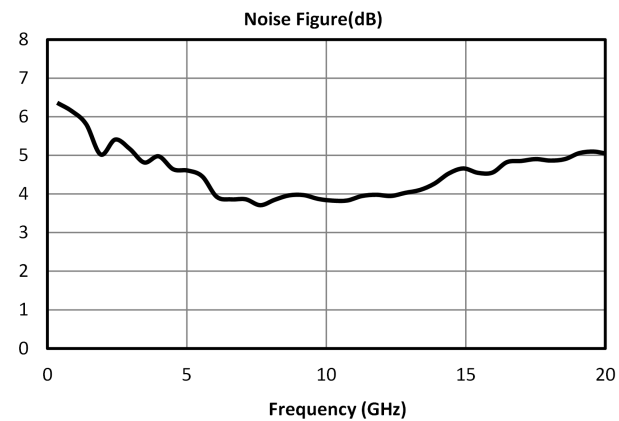

Application Information

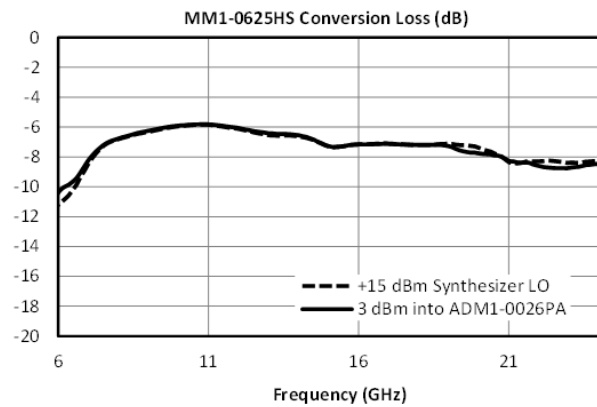
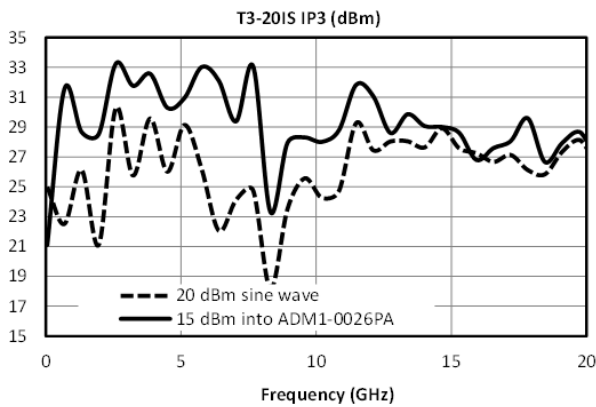
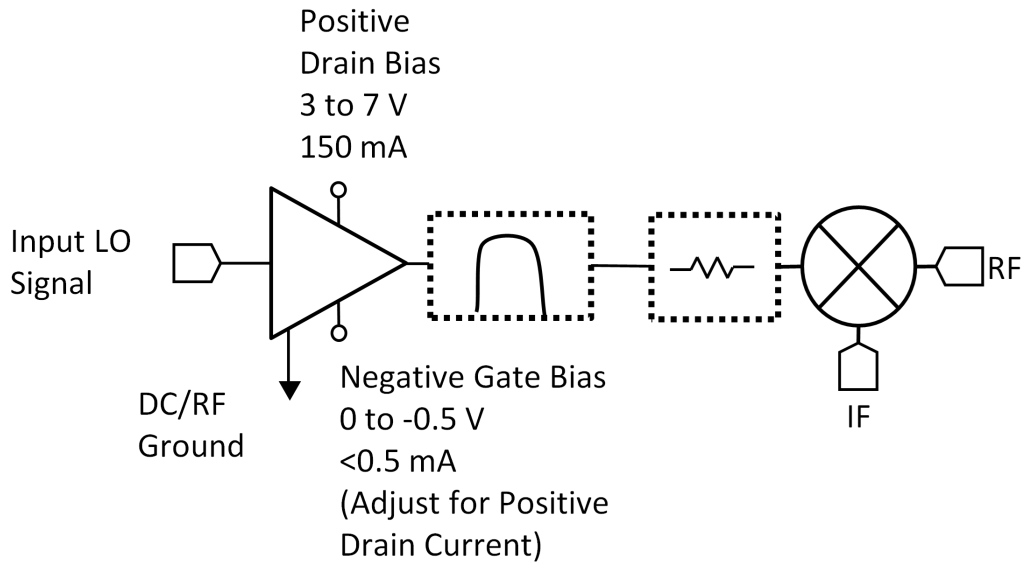

Applications Information		
Application	Input Power	Comments
T3 LO Driver	+10 to +15 dBm	Ideal choice for driving all T3 mixers down to 10 MHz. When driven beyond the 1 dB compression point (with inputs higher than 10 dBm), it will create a saturated square wave output that improves the IP3, spurious suppression, and 1 dB compression of the T3 mixer, especially at lower frequencies.
Broadband Mixer LO Driver	-5 to +10 dBm	Can be used to drive any double balanced mixer with an H diode or lower (including L, I, and M diodes). For this purpose saturated operation is not preferred, and may cause undesirable results. Input power should be kept in the -5 to +10 dBm range to provide appropriate output power, depending on the mixer.
General Purpose Linear RF Amplifier	<+5 dBm	Can be used as a general purpose amplifier for RF signals. Input power should be kept below +5 dBm for linear operation.

Biassing and Operation

Positive Bias (Vd) -Bias supply on Vd should be voltage limited below 9 V and current limited below 250 mA at all times. The operational bias voltage should be between 3 V and 7 V for full gain, efficiency, and linearity. In general linearity and output power will increase marginally with increased voltage from 3 to 7 V.

Mechanical Data

Outline Drawing

Download : [Outline 3D Drawing](#) | [Outline 3D STP](#)

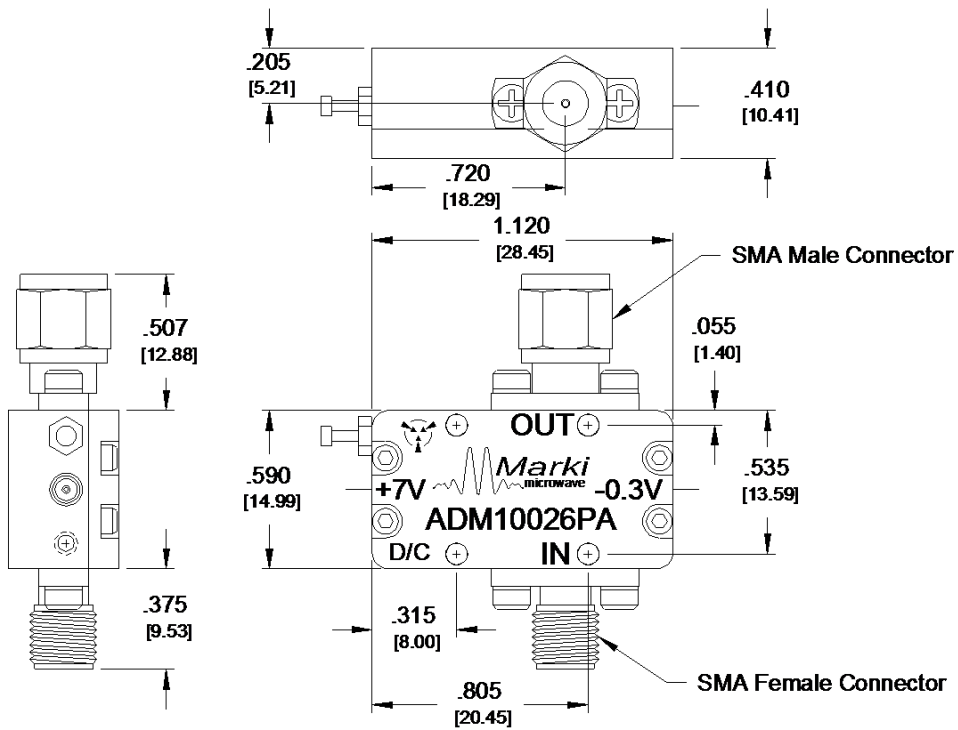

DISCLAIMER

MARKI MICROWAVE, INC., ("MARKI") PROVIDES TECHNICAL SPECIFICATIONS AND DATA (INCLUDING DATASHEETS), APPLICATION OR OTHER DESIGN ADVICE, WEB TOOLS, AND OTHER INFORMATION AND RESOURCES "AS IS" AND WITH ALL FAULTS. MARKI DISCLAIMS ALL WARRANTIES, EXPRESS OR IMPLIED, INCLUDING, WITHOUT LIMITATION, ANY IMPLIED WARRANTIES OF MERCHANTABILITY, FITNESS FOR A PARTICULAR PURPOSE, OR NON-INFRINGEMENT.

These resources are intended for developers skilled in the art designing with Marki products. You are solely responsible for (1) selecting the appropriate products for your application, (2) designing, validating, and testing your application, and (3) ensuring your application meets applicable standards and other requirements. Marki makes no guarantee regarding the suitability of its products for any particular purpose, nor does Marki assume any liability whatsoever arising out of your use or application of any Marki product. Marki grants you permission to use these resources only for development of an application that uses Marki products. Other reproduction or use of these resources is strictly prohibited. No license is granted to any other Marki intellectual property or to any third-party intellectual property. Marki reserves the right to make changes to the product(s) or information contained herein without notice.

MARKI MICROWAVE and T3 MIXER are trademarks or registered trademarks of Marki Microwave, Inc. All other trademarks used are the property of their respective owners.

© 2020, Marki Microwave, Inc