

FP3613a O-band Package

High Power DFB

Product Brief

FEATURES

- Single-frequency distributed feedback (DFB) laser chip

APPLICATIONS

- Optical Fiber Communications
- RF Photonic Links
- Fiber Optic Testing
- Medical
- Sensing

Notes

1. Non-condensing
2. Measured at specified operating power, 25C
3. Measured using our Whisperdrive laser mount
4. Above 1GHz

OVERVIEW

The FP3613 High Power Distributed Feedback (DFB) Laser is a high performance single spectral mode device, with output power of >100 mW, available in wavelengths ranging from 1260 nm to 1320 nm. The package can be operated at higher temperatures for reduced power consumption in warm ambient environments. The hermetically sealed package incorporates a two-stage internal isolator. The single mode output is in polarization maintaining fiber.

TARGET PERFORMANCE

General Parameter	Value	Unit
Output Power in Fiber with TEC at 25C FP3613a	>90	mW
Operating Current with TEC at 25C FP3613a	<600	mA
Output Power in Fiber with TEC at 85C FP3613a	>40	mW
Operating Current with TEC at 85C FP3613a	<600	mA
Center Wavelength	1260-1320	nm
Case Temperature Operating Range ¹	10 - 55	°C
Case Temperature Storage Range ¹	-10 - 85	°C
SMSR ²	>45	dB
Linewidth ^{2,3}	<300	kHz
RIN ^{2,4}	-150	dBc/Hz

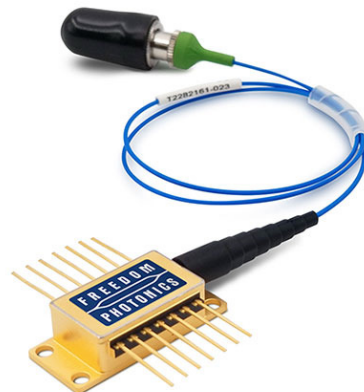

FP3613 O-band Package High Power DFB

Product Brief

FEATURES

- Single-frequency distributed feedback (DFB) laser chip

APPLICATIONS

- Optical Fiber Communications
- RF Photonic Links
- Fiber Optic Testing
- Medical
- Sensing

PINOUT

Pin	Descriptions	Pin	Descriptions
1	Thermistor	14	Optional Case &/or Laser Anode
2	Thermistor	13	Laser Anode
3	Laser Cathode	12	NC (Optional bias-T)
4	Monitor PD Anode	11	Laser Anode
5	Monitor PD Cathode	10	Optional Case &/or Laser Anode
6	TEC +	9	Optional Case &/or Laser Anode
7	TEC -	8	Optional Case &/or Laser Anode

MECHANICAL DRAWING

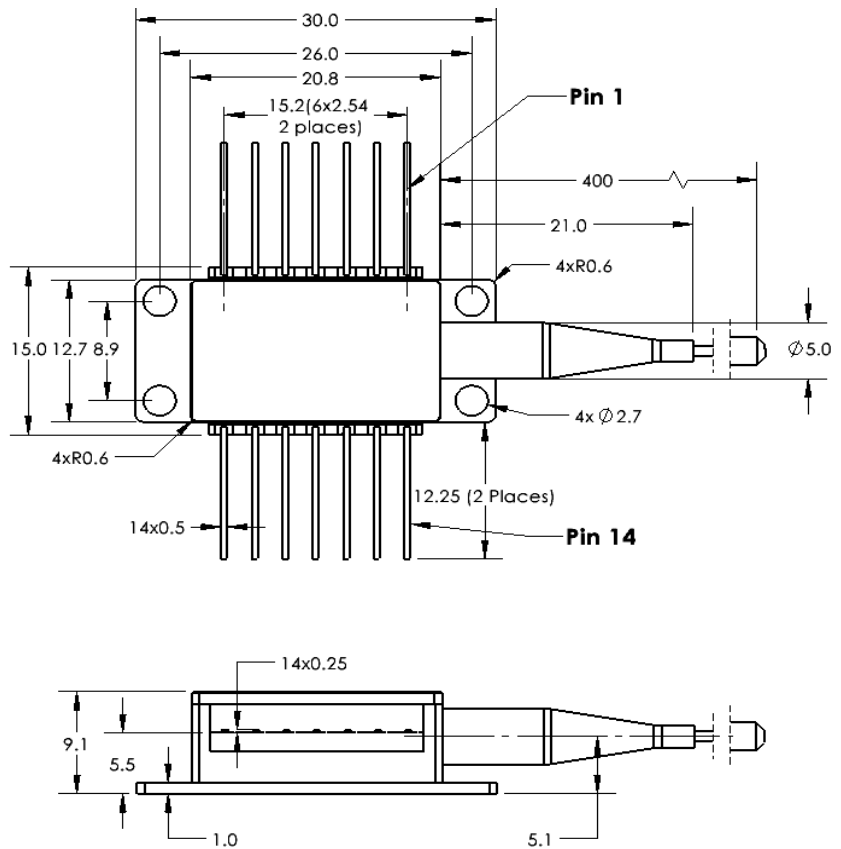

All Dimensions in millimeters