

EXS210036-01

EXS0820-025-05-0804130

SLED TOSA 820nm

Revision: 1.0
Date: 03-05-2012
Confidentiality: **None**

Prepared by : Raffaele Rezzonico
(Product Support Technician)

Checked by : Chris Armistead
(Engineering Manager)

Approved by : Philippe Crépellière
(Quality Manager)

Authorized by : Marcus Duellk
(CTO)

CONTENTS

1.	SCOPE	3
	1.1 PURPOSE.....	3
	1.2 RESPONSIBILITY	3
2.	REFERENCE DOCUMENT	3
3.	ELECTRO-OPTICAL PERFORMANCE ($T_{SLED} = 25^{\circ}C$)	3
4.	ABSOLUTE MAXIMUM RATINGS.....	3
5.	SCREENING (EXS210036-01)	4
6.	PACKAGE DIMENSIONS [MM]	4
7.	FIBRE AND CONNECTOR.....	5
8.	IMPORTANT NOTES	5
9.	ORDERING INFORMATION.....	5
	9.1 TECHNICAL DESCRIPTION.....	5
10.	REVISION HISTORY	6

1. SCOPE

1.1 PURPOSE

The purpose of this document is to specify the electro-optical performance and dimensions of superluminescent light emitting diode (SLED) TOSA.

1.2 RESPONSIBILITY

EXALOS is responsible for establishing, implementing and maintaining this procedure. The Quality representative shall ensure that a timely Engineering Change Notice (ECN) is issued in accordance with EXALOS procedure for any changes.

2. REFERENCE DOCUMENT

- EXS-WI-0001 Visual Inspection Criteria SLED Chip on Submount Procedure
- MIL STD 883 C method
- Bellcore GR-468-CORE

3. ELECTRO-OPTICAL PERFORMANCE ($T_{SLED} = 25^{\circ}C$)

Parameter	Symbol	Min	Typ	Max	Unit
Operating Current	I_{op}	0		120	mA
Power in SMF	P_o	1	2		mW
Centre Wavelength	λ_c	800	820	840	nm
3dB Bandwidth		20	25		nm
Spectral ripple [RB=0.1nm]			0.1	0.3	dB
Monitor Diode Current*	I_{MPD}	0.1			mA
Monitor diode bias voltage	V_{Bias}	0		-12	V

4. ABSOLUTE MAXIMUM RATINGS

Stresses beyond the absolute maximum ratings may cause permanent damage to the device. Exposure to absolute maximum rating conditions for extended periods may affect device reliability.

Parameter	Symbol	Cond.	Min	Max	Unit
Forward current	I_F	$P_o \leq P_{max}$		140	mA
Reverse voltage	V_R			-2	V
Forward voltage	V_F	$I_{F,max}$		3	V
Storage temperature	T_{stg}		-40	85	$^{\circ}C$
Operating temperature	T_{op}	$P_o \leq P_{max}$	-20	65	$^{\circ}C$
Max Power ex-fiber [†]	P_{max}			3	mW
Lead soldering temperature				260	$^{\circ}C$
ESD		human b.m		500	V

* Measurement conditions:

- $I_{op} = I_{op} \text{ Max}$
 - Monitor PD bias voltage: 0 Volts
- Input resistance of the Monitor PD current measurement circuit 10 Ohm

[†] The drive current may need to be adjusted in order not to exceed the maximum power rating for low ambient temperature.

5. SCREENING (EXS210036-01)

The manufactured 820nm SLED Module is required to meet all operating conditions specified in Table 4.1, Electro-Optical Performance Specifications after being subjected to the following screening tests.

Test Item	Test Conditions	Reference	Sample
Hermetic Seal (At TO-CAN Level)	Fine leak :	MIL-STD-883, Method 1014 Condition A	100 %
	Max. leak rate 5×10^{-8} atm.cc/sec Gross leak :	MIL-STD-883, Method 1014 Condition C	100 %
Temperature Cycling	-40°C to +85°C, ramp rate $\geq 5^\circ$ C/min 20 cycles	MIL-STD-883, Method 1010	100%

6. PACKAGE DIMENSIONS [mm]

Tolerances: .X ± 0.25 mm
.XX ± 0.05 mm

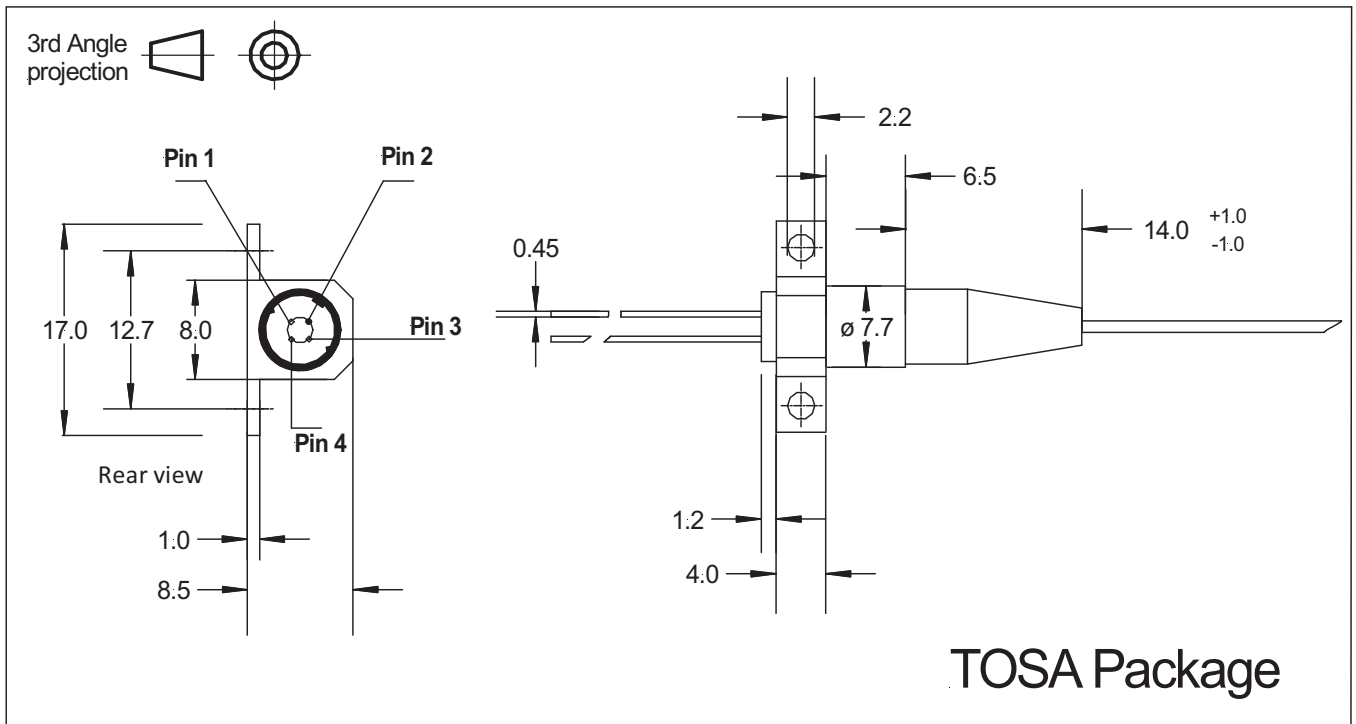

EXS210036-01	
Pin	Function
1	MONITOR DIODE ANODE
2	SLED CATHODE (-), MONITOR DIODE CATHODE , CASE
3	SLED ANODE (+)
4	NC

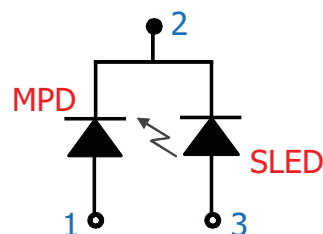

7. FIBRE AND CONNECTOR

Part	Description
SM Fibre	SM 5/125 Corning HI780
Loose tube	900 µm
Fibre pigtail length [min]	1 m
Optical connector	FC/APC (Narrow Key 2.0mm)

8. IMPORTANT NOTES

1. Avoid electrostatic discharges, which may destroy the SLED.
2. Never use the bare die without heat sinking.
3. Adequate eye protection against laser radiation should be used while handling and operating the module.
4. EXALOS declines any responsibility if the device is used in applications where human life may be endangered.
5. Back reflections may influence the output power and spectral characteristics of the SLED. The use of optical isolators and/or angled connectors is recommended. Back reflections of less than -30dB are recommended.

9. ORDERING INFORMATION

Please use the following **part number** to order product from EXALOS:

E X S 2 1 0 0 3 6 - 0 1

9.1 TECHNICAL DESCRIPTION

