

EXS7505-B001

EXS0750-020-05-0B00010

750nm UNCOOLED TO-56

Revision: 3.0

Date: 12-02-2009

Confidentiality: **None**

Prepared by: Raffaele Rezzonico
(Product Support Technician)

Checked by: Chris Armistead
(Engineering Manager)

Approved by: Philippe Crépeillère
(Quality Manager)

Authorized by: Marcus Duellk
(CTO)

CONTENTS

1. SCOPE.....	3
1.1 PURPOSE.....	3
1.2 RESPONSIBILITY	3
2. REFERENCE DOCUMENT.....	3
3. ELECTRO-OPTICAL PERFORMANCE ($T_{SLED} = 25^{\circ}C$)	3
4. ABSOLUTE MAXIMUM RATINGS	4
5. SCREENING (EXS7505-B001).....	4
6. PACKAGE DIMENSIONS [mm]	5
6.1 DETAILED DIMENSIONS [mm]	6
7. IMPORTANT NOTES.....	7
8. ORDERING INFORMATION.....	7
9. REVISION HISTORY	8

1. SCOPE

1.1 PURPOSE

The purpose of this document is to specify the electro-optical performance and dimensions of superluminescent light emitting diode (SLED) TO-56.

1.2 RESPONSIBILITY

EXALOS is responsible for establishing, implementing and maintaining this procedure. The Quality representative shall ensure that a timely Engineering Change Notice (ECN) is issued in accordance with EXALOS procedure for any changes.

2. REFERENCE DOCUMENT

- EXS-WI-0001 Visual Inspection Criteria SLED Chip on Submount Procedure
- MIL STD 883 C method.
- Bellcore GR-468-CORE

3. ELECTRO-OPTICAL PERFORMANCE ($T_{SLED} = 25^{\circ}C$)

Parameter	Symbol	Min	Typ	Max	Unit
Operating Current	I_{op}	0		120	mA
Power ex-window	P_o	5	10	-	mW
Centre Wavelength*	λ_c	730	750	770	nm
Bandwidth FWHM*		15	20	-	nm
Spectral ripple [RB=0.1 nm]		-	0.1	-	dB
Monitor Diode Current	I_{MPD}	-	5 [†]	-	mA
Vertical Far Field Angle FWHM		-	40	-	degrees
Horizontal Far Field Angle FWHM		-	15	-	degrees

*Spectral verification is performed by sampling at the manufacturing batch level. Manufacturing batches are defined by epitaxial wafer growth run

[†] Measurement conditions:

- $I_{op} = I_{op} \text{ Max}$
- Monitor PD bias voltage: 0 Volts

Input resistance of the Monitor PD current measurement circuit ~ 6 Ohm

4. ABSOLUTE MAXIMUM RATINGS

Stresses beyond the absolute maximum ratings may cause permanent damage to the device. Exposure to absolute maximum rating conditions for extended periods may affect device reliability.

Parameter	Symbol	Cond.	Min	Max	Unit
Forward current	I_F	$P_o \leq P_{max}$		140	mA
Reverse voltage	V_R			-2	V
Forward voltage	V_F	$I_{F,max}$		2.5	V
Storage temperature	T_{stg}		-40	85	°C
Operating temperature	T_{op}	$I_{F,max}$	-20	65	°C
Lead soldering temperature				260	°C
Max Power ex-window [‡]	P_{max}			20	mW
ESD		human b.m		500	V
Monitor diode reverse bias voltage	V_{Bias}		0	-2	V

5. SCREENING (EXS7505-B001)

The produced 750nm SLED Module is required to meet all operating conditions specified in Table 4.1, Electro-Optical Performance Specifications after being subjected to the following screening tests.

Test Item	Test Conditions	Reference	Sample
Hermetic Seal	Fine leak :	MIL-STD-883, Method 1014	100 %
	Max. leak rate 5×10^{-8} atm.cc/sec	Condition A	
Temperature Cycling	Gross leak :	MIL-STD-883, Method 1014	100 %
	-40°C to +85°C, ramp rate $\geq 5^\circ$ C/min 20 cycles	Condition C	
		MIL-STD-883, Method 1010	100%

[‡] The drive current may need to be adjusted in order not to exceed the maximum power rating for low ambient temperature.

6. PACKAGE DIMENSIONS [mm]

Tolerances: See section 6.1

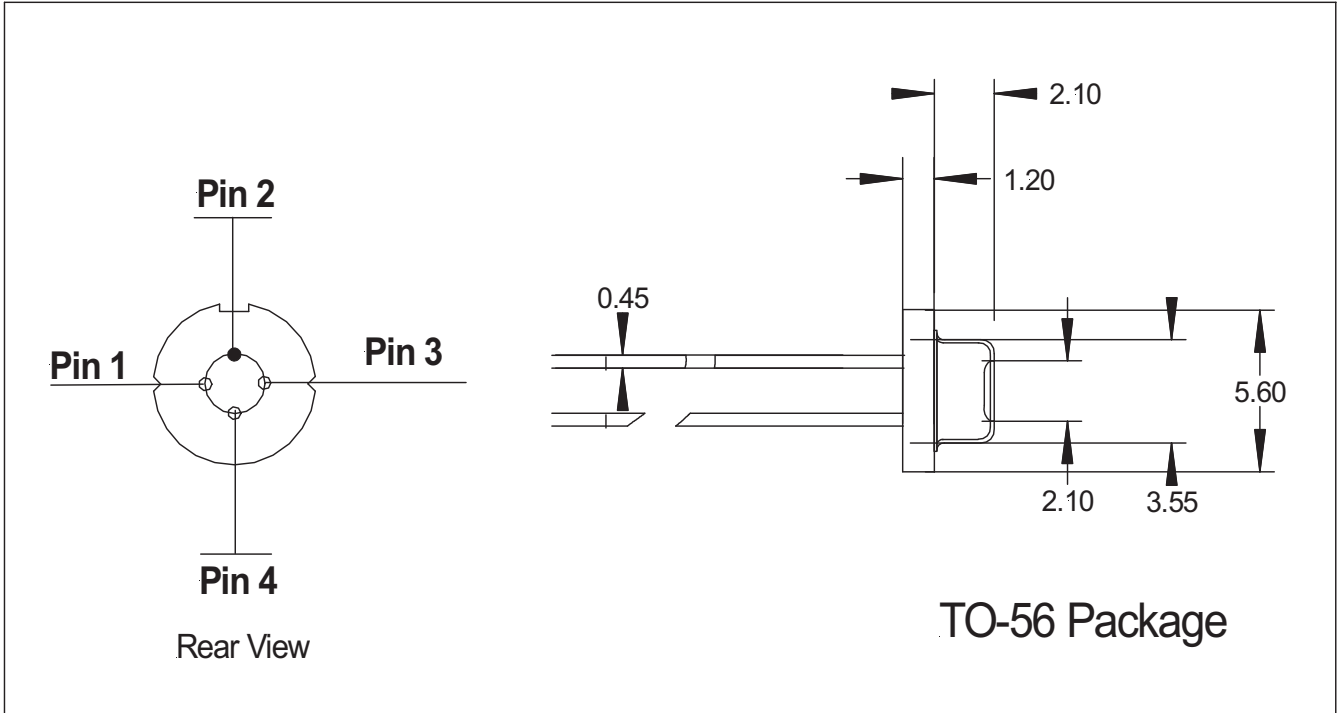

TO-CAN	
Pin	Function
1	MONITOR DIODE ANODE
2	SLED (-), CASE, MONITOR DIODE CATHODE
3	SLED (+)
4	NC

Attention

Prior to connecting the SLED module to the driver using constant power mode, make sure that your SLED driver supports the so-called "Common laser cathode/photodiode cathode" arrangement and the connections are set accordingly. If this is not the case do not connect the SLED, otherwise it may result in permanent damage to the SLED.

SCHEMATIC PIN LAYOUT

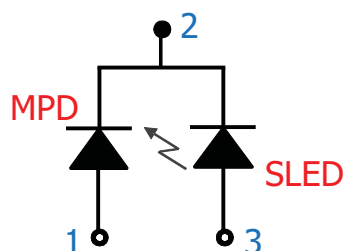

7. IMPORTANT NOTES

1. Avoid electrostatic discharges, which may destroy the SLED.
2. Never use the TO-CAN die without heat sinking.
3. Adequate eye protection against laser radiation should be used while handling and operating the module.
4. EXALOS declines any responsibility if the device is used in applications where human life may be endangered.
5. Back reflections may influence the output power and spectral characteristics of the SLED. The use of optical isolators and/or angled connectors is recommended. Back reflections of less than -30dB are recommended.

8. ORDERING INFORMATION

Please use the following code system to order products from EXALOS.

SLED EXS7505-B001 Product coding:

