

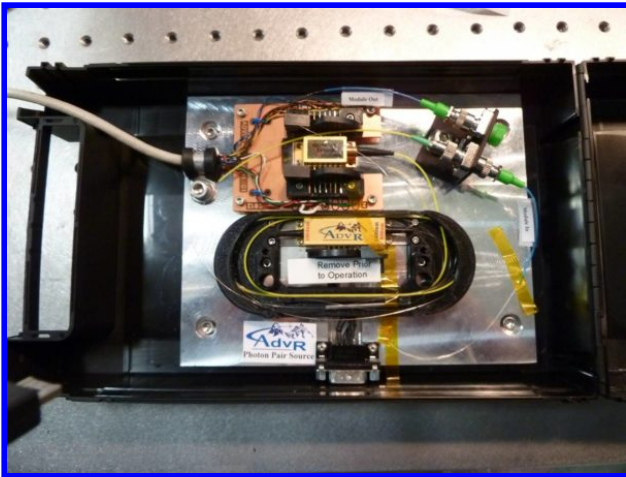

Waveguide Based Quantum Devices

Photon Pair Sources



AdvR's PPKTP waveguides have been used to produce promising results in the field of quantum information. Researchers can use Type 0 and Type II frequency conversion to make advancements

- GHz/mW Pair Generation Rates for Type 0 Interactions
- MHz/mW Pair Generation Rates for Type II Interactions
- Custom Degenerate or Non-Degenerate Interactions
- Common Interaction Included 405 nm -> 810 nm and 775 nm -> 1550 nm SPDC.
- Options for Unpackaged Waveguide Chip, Fiber Coupled Devices, and Timing Compensated Devices

Type II Timing Compensated Photon Pair Sources

Material	PPKTP Waveguide	
Pump Wavelength (nm)	405	775
SPDC Wavelength (nm)	810	1550
Internal Pair Generation Rate (MHz/mW)	> 10	≥ 3
HOM Visibility	> 90% *	
Input Fiber	PM400	PM850
Output Fiber	PM850	PM1550
Fiber Connectors	FC/APC	

* > 95% Measured

Contact us to discuss more options, including dual element devices for polarization entangled photon pairs or unique interactions such as 1064nm pump → (532nm internal SHG) → 810nm & 1550nm photon pairs.

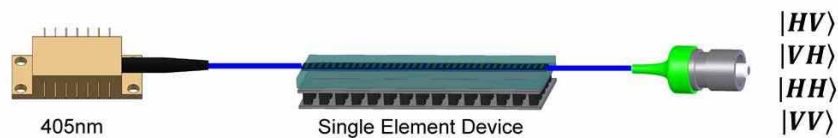

Single Photon Quantum Frequency Conversion

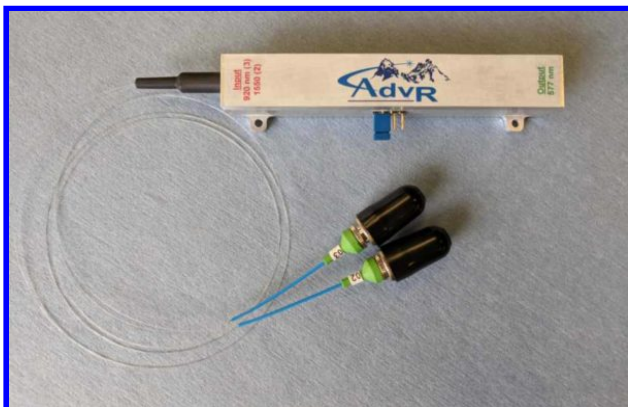

AdvR offers a line of Undoped LN waveguides for high efficiency single photon conversion. These waveguides can convert single photons from visible wavelengths to the telecom from low loss transmission, or from telecom to visible for efficient detection and interactions with atoms.

On-chip features including mode-filters and WDMs allow for efficient fiber coupling wavelengths through separate ports.

Single Photon Downconversion Device

Example Configuration

(View Other Example Configurations)

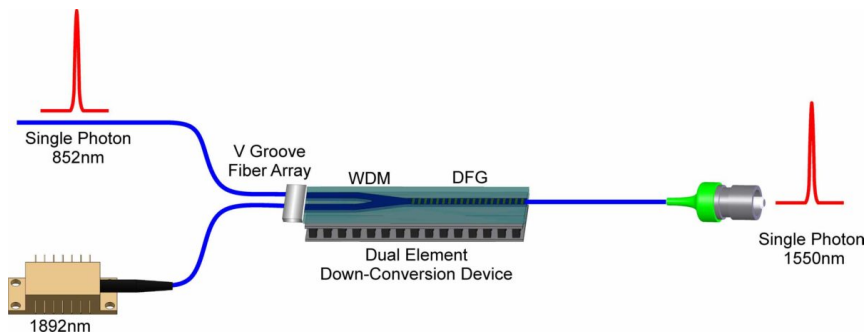

Single Photon Upconversion Device

Example Configuration

(View Other Example Configurations)

