

# ***NFAD with TEC***

***(TO-8 Negative Feedback Avalanche Diode)***

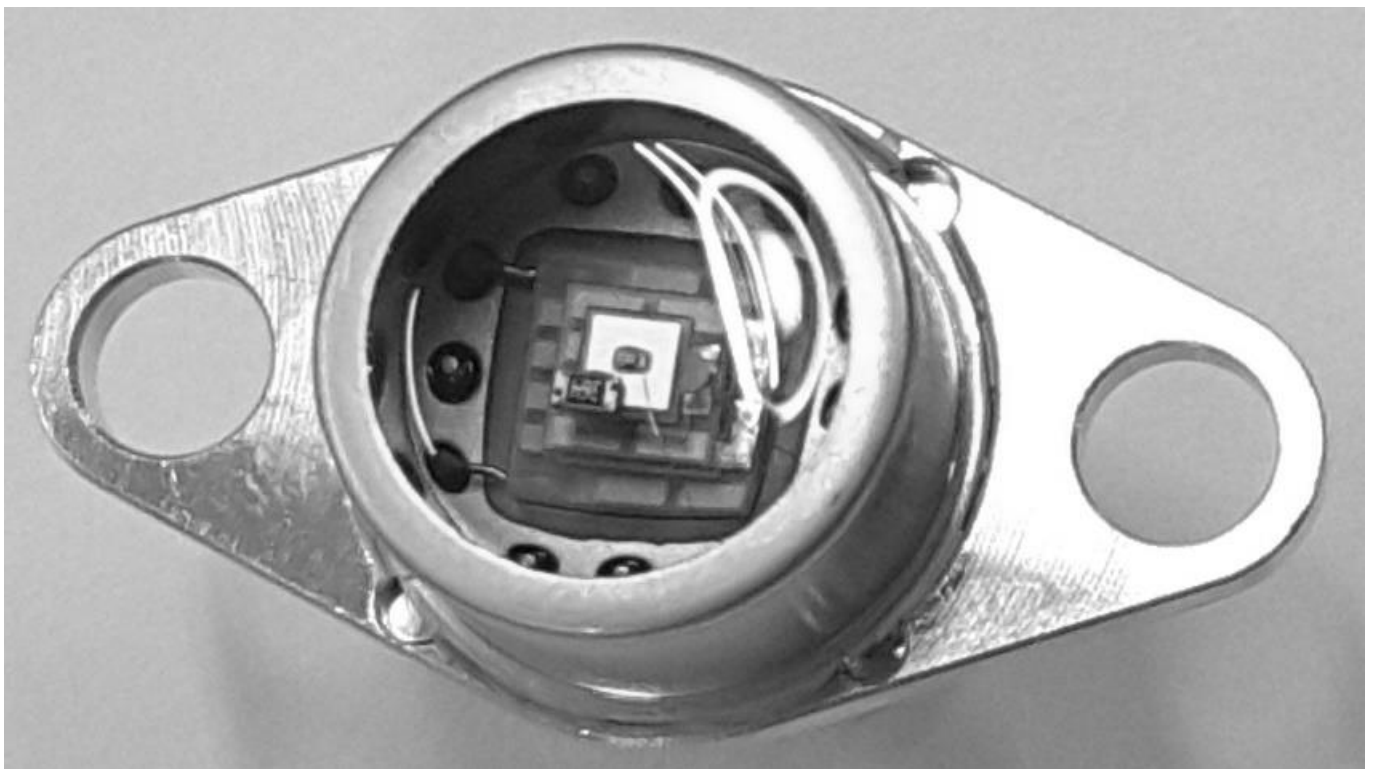

*Contents*

**General Description** ..... 3

**Electro-Optical Characteristics** ..... 4

**Mechanical Dimension & Pin Layout** ..... 5

**Other Requirements** ..... 7

## General Description

**InGaAs NFAD** (Negative Feedback Avalanche Diode) is used for photon counting such as ultra-long distance Light Detection and Ranging (LiDAR) and Laser Range Finder (LRF), Free Space Quantum Communication, anything requires minute photon counting application, such as Gas sensors and Bio sensors, etc. It is based on the theory of low noise and high speed photo detection system using optical feedback with a current amplification function.

## Features

- Free Running Mode operation
- Built-in Quenching Resistor (Available Option : 360 kΩ/ 510 kΩ/ 680 kΩ/ 820 kΩ/ 1MΩ)
- Optimized for 1000 nm to 1600 nm Wavelength
- Free Space
- Built in 3-stage Cooling System (TEC)
- Customized PIN map available

## Applications

- Gas Leakage Sensor
- Quantum Cryptography (QKD)
- Light Detection and Ranging (LiDAR)
- Free Space Optical Communication
- Fundamental Studies in Quantum Physics

## Absolute Maximum Ratings

Parameter	Conditions	Rating(Max.)	Unit
Forward Current	Continuous bias	1	mA
Forward Voltage	Continuous bias	1	V
Reverse Current	Continuous bias	1	mA
Reverse Voltage	DC Bias (free-running mode)	$V_{BR} + 5$	V
Optical Input Power	Continuous wave	1	mW
TEC Current	@27°C, Vacuum	2.6	A
TEC Voltage	@27°C, Vacuum	2.0	V
Thermistor	@25°C	10	kΩ
Storage Temperature	-	-40 to +85	°C

Table 1. Absolute Maximum Ratings

## Electro-Optical Characteristics

Inspection sheet shall be appended to products when they are delivered. Test report shall be submitted in papers and in electronic media. It shall contain the major in following items.

### Optical Characteristics (Tc=25°C)

Parameter	Symbol	Test Condition	Min	Typ.	Max	Unit
Breakdown Voltage	$V_{BR}$	$I_D=0.1\mu A$	60	70	80	V
Total dark current	$I_D$	$V_R = 0.95V_{BR}$		1		nA
Capacitance	$C_{PD}$	f = 1MHz, $V_{PD} = 0.9V_B$		0.1		pF
Quantum efficiency	$\eta$	M=1, 1550nm		70		%
Optical Wavelength Range	$\lambda$	-	1000		1600	nm
Responsivity	R	$\lambda = 1550nm, M=1$	0.7	0.8		A/W
Temperature coefficient of $V_{BR}$	$\Gamma$	$\Delta V_{BR}/\Delta T$		0.11		V/°C

Table 2. Optical Characteristics

### Optical Characteristics (Tc= -40°C)

Parameter	Symbol	Test Condition	Min	Typ.	Max	Unit
Photon Detection efficiency	PDE	$T_C=-40^\circ C$	10			%
Dark count rate	DCR	@10% PDE $T_C=-40^\circ C$			10	KHz
Operating Excess voltage	$\Delta V$			+2		V

Table 3. Optical Characteristics at GM operation

※ Note : Optical characteristics are based on the measurement result with pigtailed.

### Mechanical Dimension & Pin Layout

(Unit : mm)

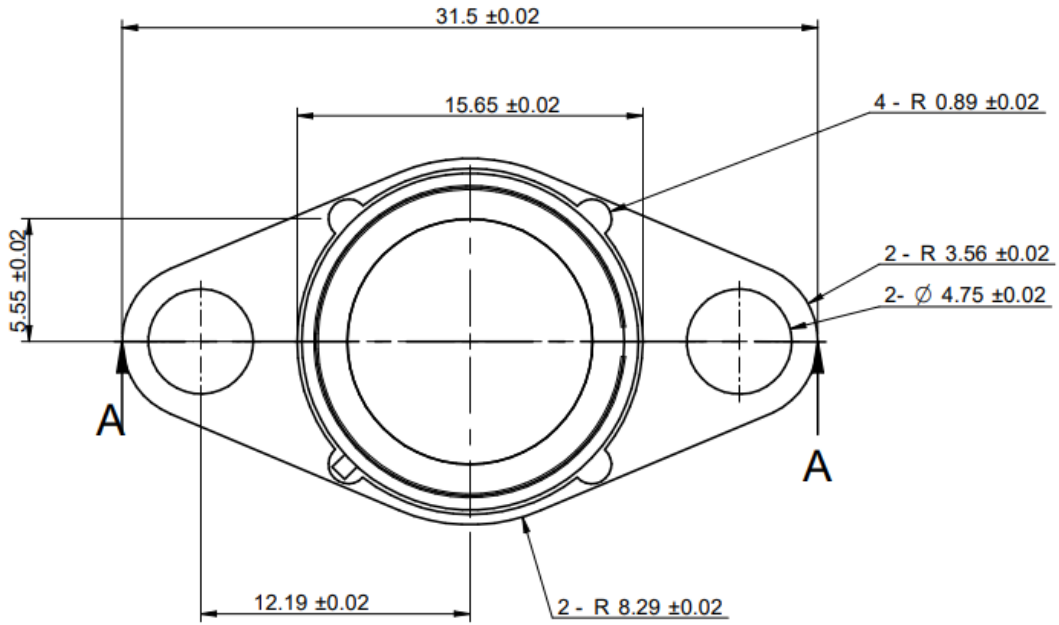

< TOP VIEW >

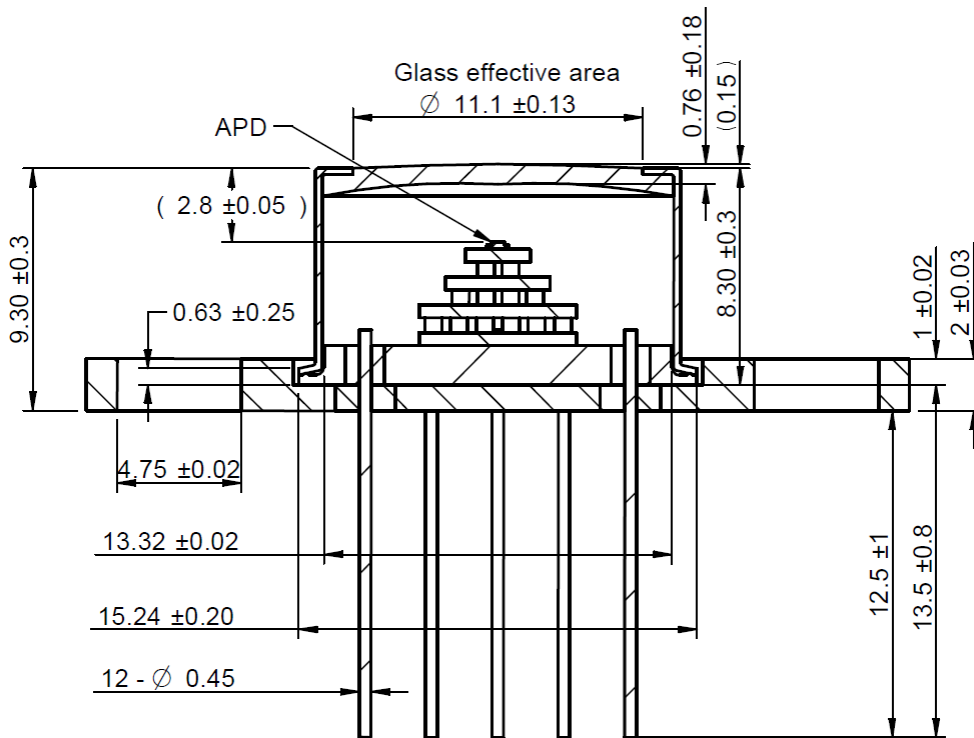

SECTION A-A

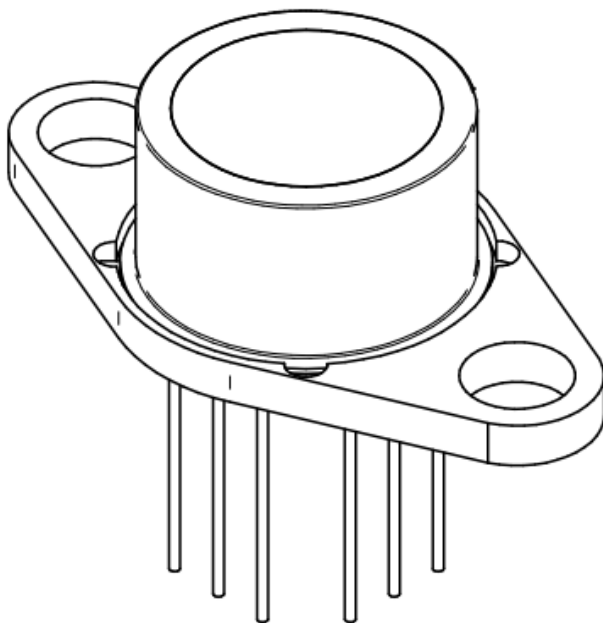
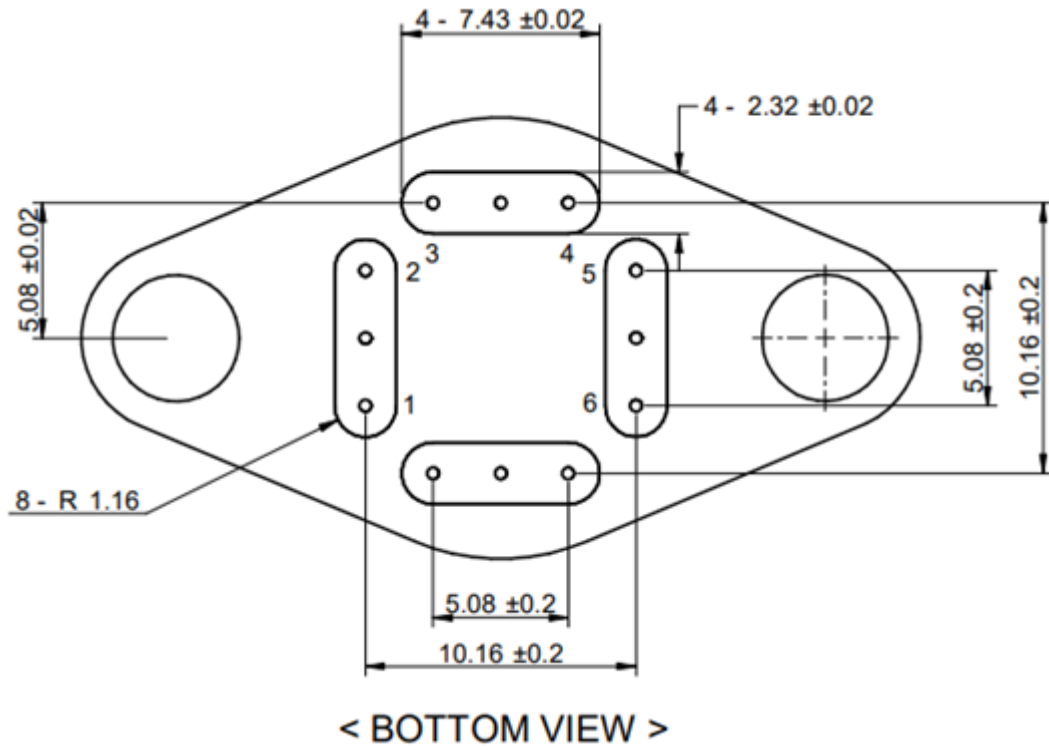

No.	Description
1	TEC (-)
2	TEC (+)
3	APD Anode (with Qr)
4	APD Cathode
5	Thermistor1
6	Thermistor2

Figure 1. Mechanical Dimension and Standard PIN map

## Other Requirements

### Precautions for use

This device is susceptible to damage as a result of ESD(electrostatic discharge). Use of ground straps, anti static mats, and other standard ESD protective equipment is recommended when handling or testing an InGaAs PIN/APD or any other junction photodiode. Soldering temperature of the leads should not exceed 350°C for more than 3 seconds.

## Ordering Information

WPGSNGMLJNNCFO (NFAD with TEC TO-8 Free Space type with standard PIN map)

WPRDNGMLCNNCFO (NFAD with TEC TO-8 Free Space type with customized PIN map)