

Up to 25 Gbit/s VCSEL Single Mode Fiber-Coupled Module (1550 nm)

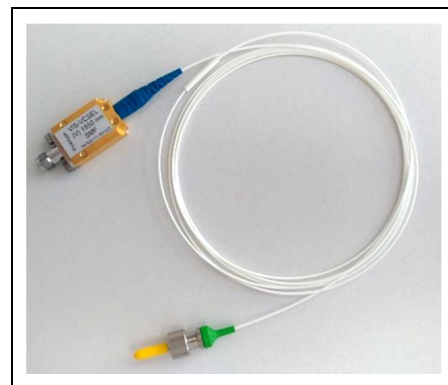

Sample image only. Actual product may vary

Product Code: V25-1550M

Product Description

High-speed transmitter module for test purpose with integrated 1550nm VCSEL fiber coupled to a 9/125 μm single mode fiber for optical output. The module is designed as engineering sample for high speed test applications.

Features

- SMF Pigtail (9 μm core, 1 m length)
- FC/APC optical output connector (N-Type)
- Anritsu V electrical connector

Applications

- Transmissions test
- Research and development

Parameter	
VCSEL type	Single mode
Emission wavelength	1550 nm
Data rate	Up to 25 Gbit/s
Peak output power	2.2 mW

All product specifications and descriptions are subject to change without notice.
Please contact our sales department for additional information and to receive a quotation: sales@v-i-systems.com

Optical spectrum

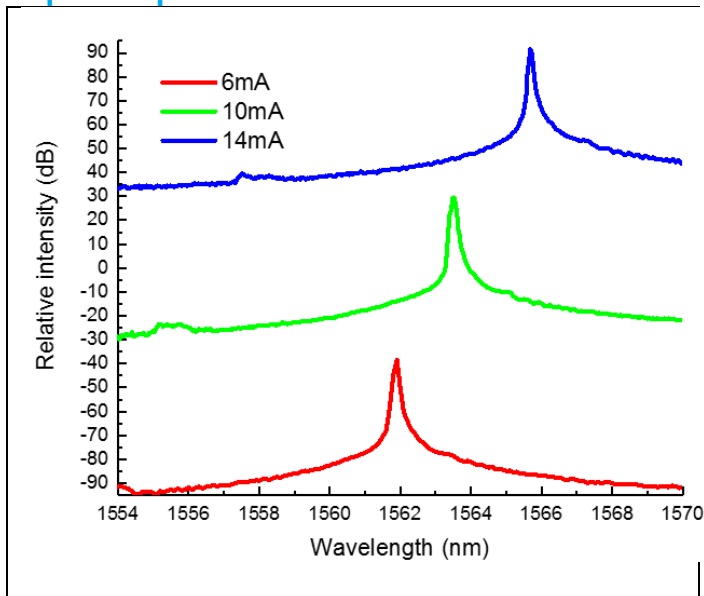

L-I-V Diagram

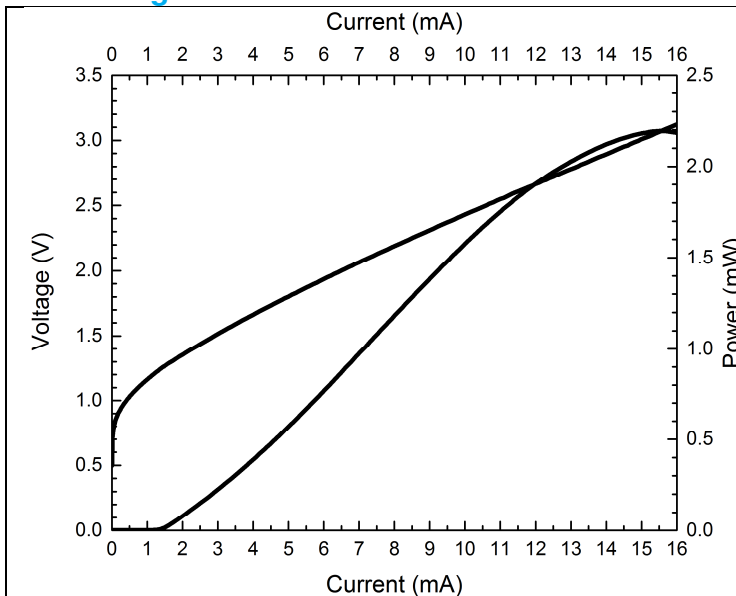

Electro-optical characteristics (at T_{case} = 25 °C)

Parameter	Symbol	Test Condition	Min	Typ	Max	Unit
Emission wavelength	λ		1550		1570	nm
Maximum data rate	BR	NRZ		25	30	Gbit/s
Bandwidth	BW (f_{3dB})			13		GHz
Rise / Fall time	τ_R / τ_F	20%-80%		20 / 20		ps
Slope efficiency	η	5-10 mA	0.2		0.35	W/A
Threshold current	I_{th}				1.8	mA
Peak output power	P_{max}				2.2	mW
Optical spectrum				single mode		
Side mode suppression ratio	SMSR		25			dB

Absolute Maximum Ratings

Parameter	Symbol	Min	Max	Unit
Storage temperature	T_{st}	-40	+90	°C
Maximum forward current	I_f		16	mA
Maximum reverse voltage	V_{rv}		4	V

All product specifications and descriptions are subject to change without notice.

Please contact our sales department for additional information and to receive a quotation: sales@v-i-systems.com

Datasheet

V25-1550M



Vertically Integrated Systems

Eye diagram at 25 Gbit/s

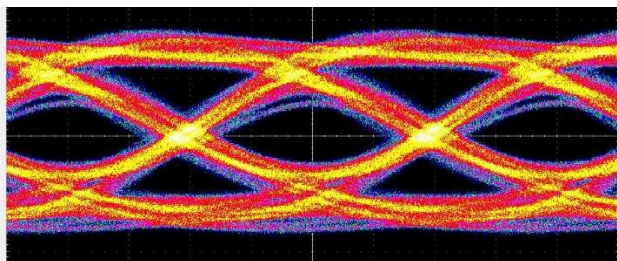

Receiver: Tektronix 80C15-32 GHz

Mechanical dimensions

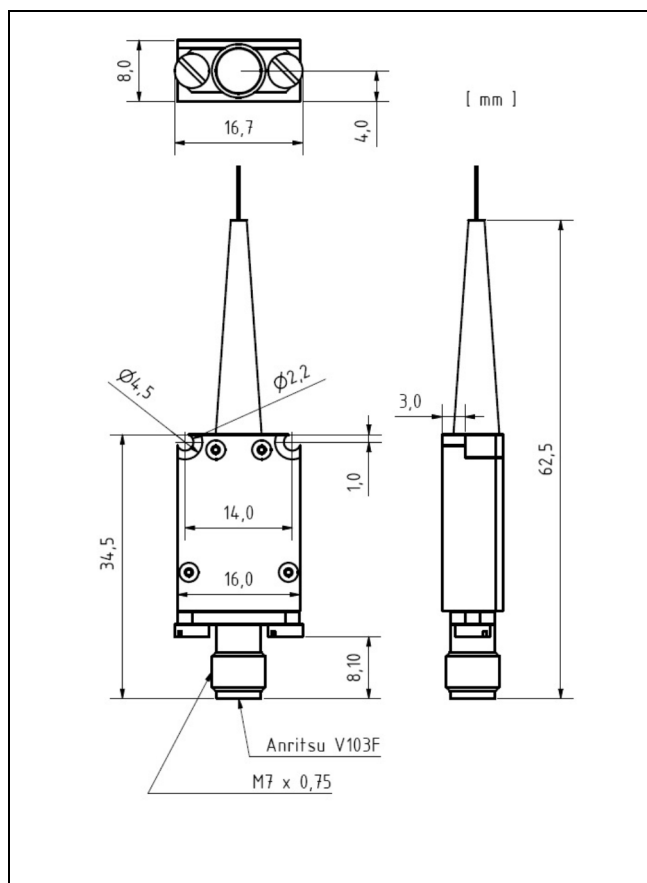

Schematic diagram

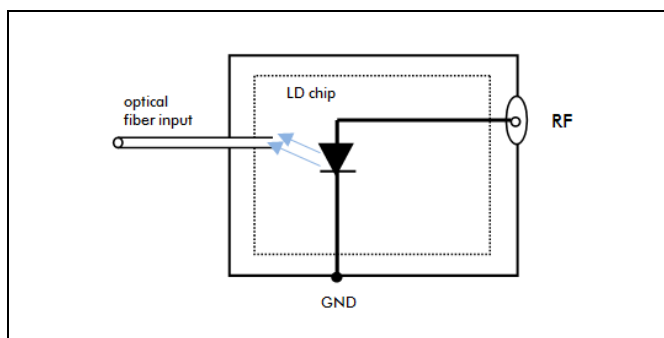

LASER RADIATION. DO NOT VIEW DIRECTLY WITH OPTICAL INSTRUMENTS
CLASS 1M LASER PRODUCT



VI Systems GmbH
Hardenbergstrasse 7
10623 Berlin
Tel.: +49 30 3083143 30
Fax: +49 30 3083143 59
sales@v-i-systems.com
www.v-i-systems.com

All product specifications and descriptions are subject to change without notice.
Please contact our sales department for additional information and to receive a quotation: sales@v-i-systems.com

www.v-i-systems.com

VI Systems GmbH Hardenbergstrasse 7 D-10623 Berlin