

## Up to 28 Gbit/s VCSEL Multi-Mode Fiber-Coupled Module (850 nm)

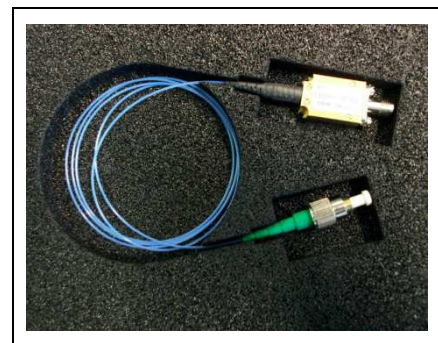

Sample image only. Actual product may vary

Product Code: **V25-850M**

### Product Description

High-speed transmitter module for test purpose with integrated 850nm VCSEL fiber coupled to an OM3 multimode fiber for optical output. The module is designed as engineering sample for high speed test applications.

Multi mode and single mode VCSEL versions are available.

### Features

- OM3 MMF Pigtail (50  $\mu$ m core, 1 m length)
- FC/PC optical output connector
- Anritsu V electrical connector
- Multi Mode and Single Mode VCSEL versions

### Applications

- 16/32G Fibre Channel systems tests
- CEI-25 (25 and 28 Gb/s) systems tests
- 25G Ethernet channel testing

Parameter	V25-850M-MM	V25-850M-SM
VCSEL type	Multi mode	Single mode
Emission wavelength	850 nm (available 835 – 865 nm)	850 nm (available 835 – 865 nm)
Data rate	Up to 28 Gbit/s	Up to 28 Gbit/s
Peak output power	4 mW	1 mW

All product specifications and descriptions are subject to change without notice.

Please contact our sales department for additional information and to receive a quotation: [sales@v-i-systems.com](mailto:sales@v-i-systems.com)

# Datasheet

## V25-850M



Vertically Integrated Systems

### V25-850M-MM: Multi mode VCSEL version

#### Optical spectrum

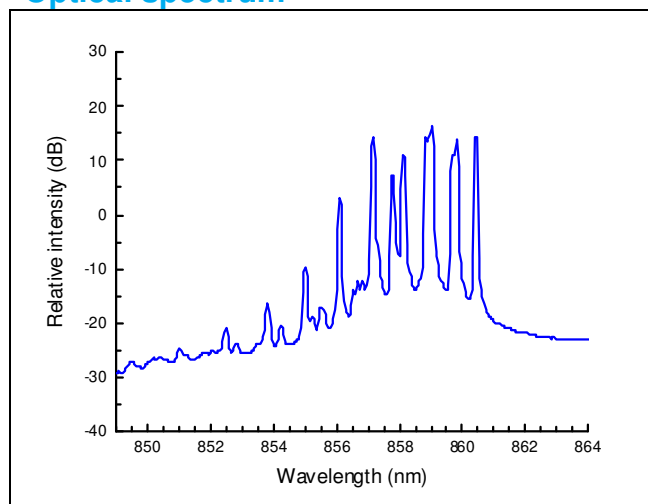

#### L-I-V Diagram

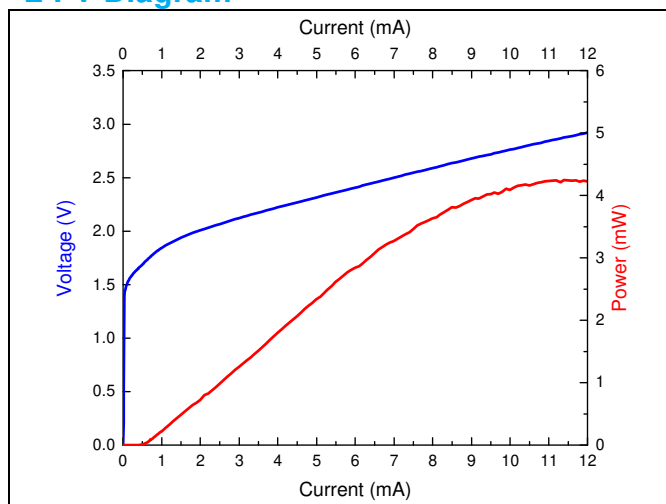

#### Electro-optical characteristics (at T<sub>case</sub> = 25 °C)

Parameter	Symbol	Test Condition	Min	Typ	Max	Unit
Emission wavelength	$\lambda$		835		865	nm
Maximum data rate	BR	NRZ		25	28	Gbit/s
Bandwidth	BW ( $f_{3dB}$ )			18		GHz
Rise / Fall time	$\tau_R / \tau_F$	20%-80%		15 / 15		ps
Slope efficiency	$\eta$	5-10 mA	0.3		0.45	W/A
Threshold current	$I_{th}$				1	mA
Peak output power	$P_{max}$				4	mW
Optical spectrum				Multi mode		
Spectral bandwidth (RMS)	$\Delta\lambda_{RMS}$		0.2	0.4	0.6	nm

#### Absolute Maximum Ratings

Parameter	Symbol	Min	Max	Unit
Storage temperature	$T_{st}$	-40	+90	°C
Maximum forward current	$I_f$		9	mA
Maximum reverse voltage	$V_{rv}$		5	V

All product specifications and descriptions are subject to change without notice.

Please contact our sales department for additional information and to receive a quotation: sales@v-i-systems.com

[www.v-i-systems.com](http://www.v-i-systems.com)

VI Systems GmbH Hardenbergstrasse 7 D-10623 Berlin

# Datasheet

## V25-850M



Vertically Integrated Systems

### V25-850M-SM: Single mode VCSEL version

#### Optical spectrum

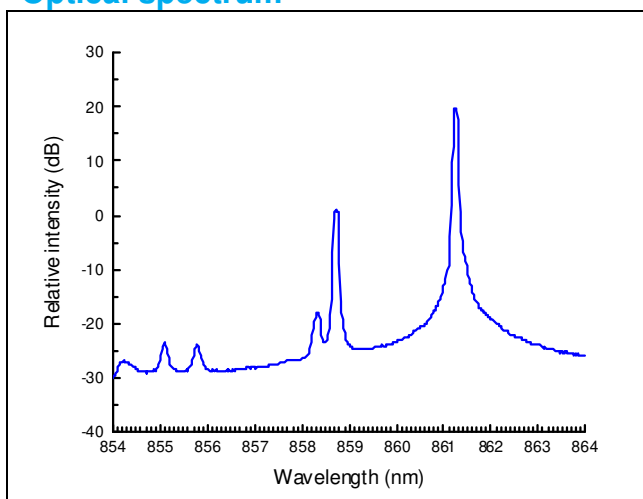

#### L-I-V Diagram

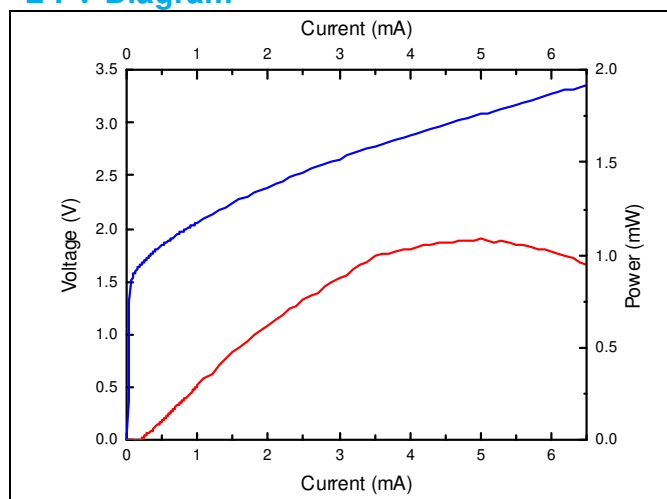

#### Electro-optical characteristics (at T<sub>case</sub> = 25 °C)

Parameter	Symbol	Test Condition	Min	Typ	Max	Unit
Emission wavelength	$\lambda$		835		865	nm
Maximum data rate	BR	NRZ		25	28	Gbit/s
Bandwidth	BW ( $f_{3dB}$ )			18		GHz
Rise / Fall time	$\tau_R / \tau_F$	20%-80%		15 / 15		ps
Slope efficiency	$\eta$	2-4 mA	0.2		0.35	W/A
Threshold current	$I_{th}$				1	mA
Peak output power	$P_{max}$				1	mW
Optical spectrum				Single mode		
Side mode suppression ratio	SMSR			15		dB

#### Absolute Maximum Ratings

Parameter	Symbol	Min	Max	Unit
Storage temperature	$T_{st}$	-40	+90	°C
Maximum forward current	$I_f$		4	mA
Maximum reverse voltage	$V_{rv}$		5	V

All product specifications and descriptions are subject to change without notice.  
Please contact our sales department for additional information and to receive a quotation: [sales@v-i-systems.com](mailto:sales@v-i-systems.com)

[www.v-i-systems.com](http://www.v-i-systems.com)

VI Systems GmbH Hardenbergstrasse 7 D-10623 Berlin

# Datasheet

## V25-850M



Vertically Integrated Systems

### Eye diagram at 28 Gbit/s

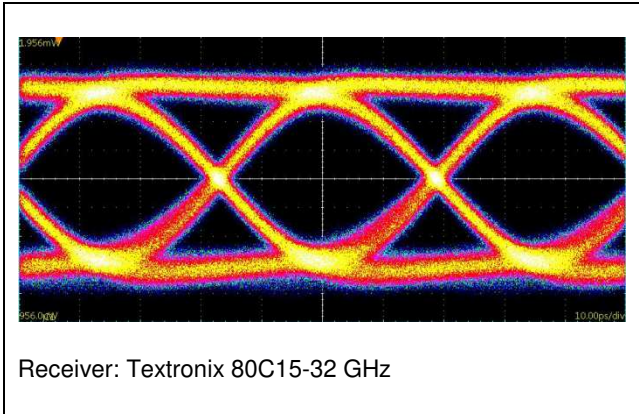

### Mechanical dimensions

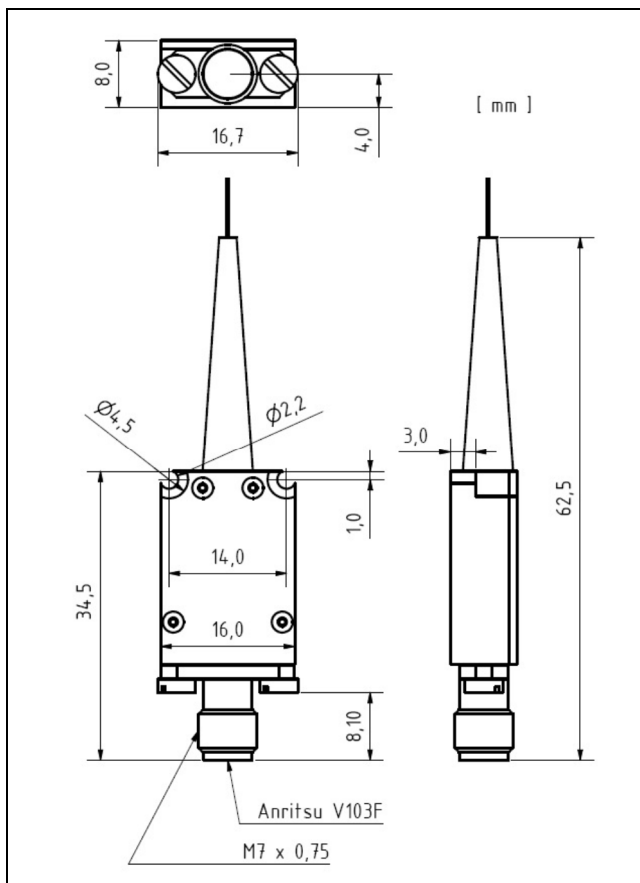

### Schematic diagram

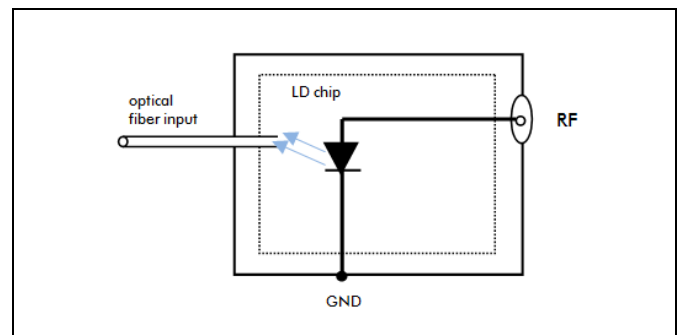

LASER RADIATION. DO NOT VIEW  
DIRECTLY WITH OPTICAL  
INSTRUMENTS  
CLASS 1M LASER PRODUCT



**VI Systems GmbH**  
Hardenbergstrasse 7  
10623 Berlin  
Tel.: +49 30 3083143 30  
Fax: +49 30 3083143 59  
sales@v-i-systems.com  
www.v-i-systems.com

All product specifications and descriptions are subject to change without notice.  
Please contact our sales department for additional information and to receive a quotation: sales@v-i-systems.com

[www.v-i-systems.com](http://www.v-i-systems.com)

VI Systems GmbH Hardenbergstrasse 7 D-10623 Berlin