

General Description

KR Electronics part number 3434-21-SMA is a 21 MHz Notch filter. The filter has a typical 3 dB bandwidth of 6.7 MHz. Other center frequencies and are bandwidths available. Please consult the factory.

Features

- 21 MHz Notch
- 3 dB Bandwidth 6.7 MHz typical
- 50 Ω Source and Load
- SMA Connectors

Typical Performance

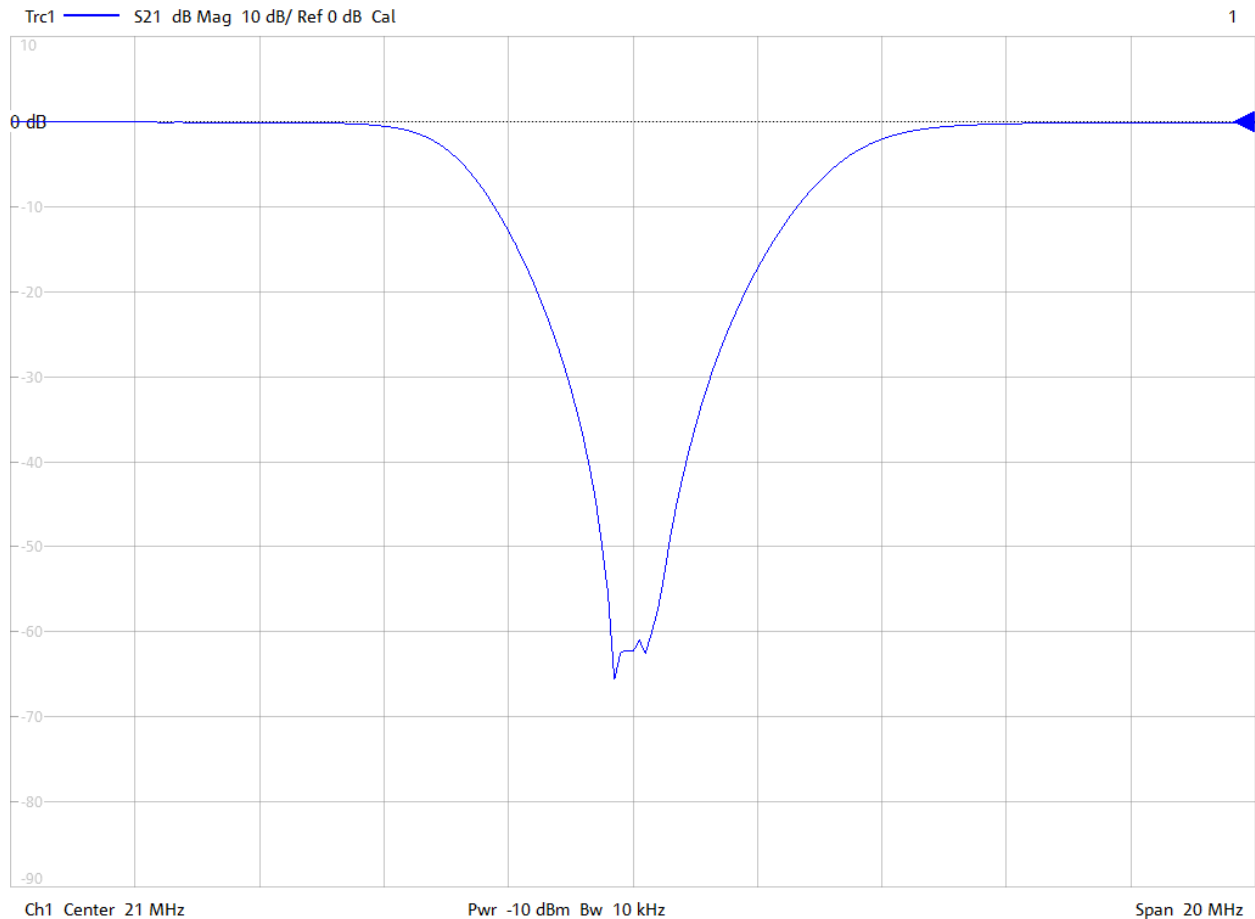

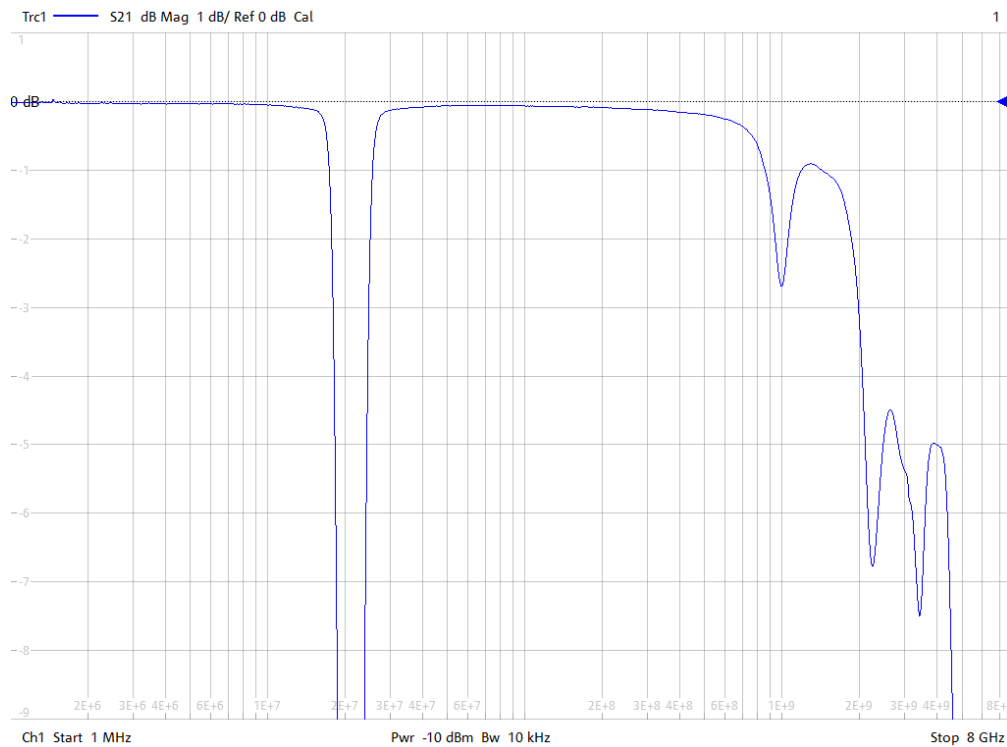
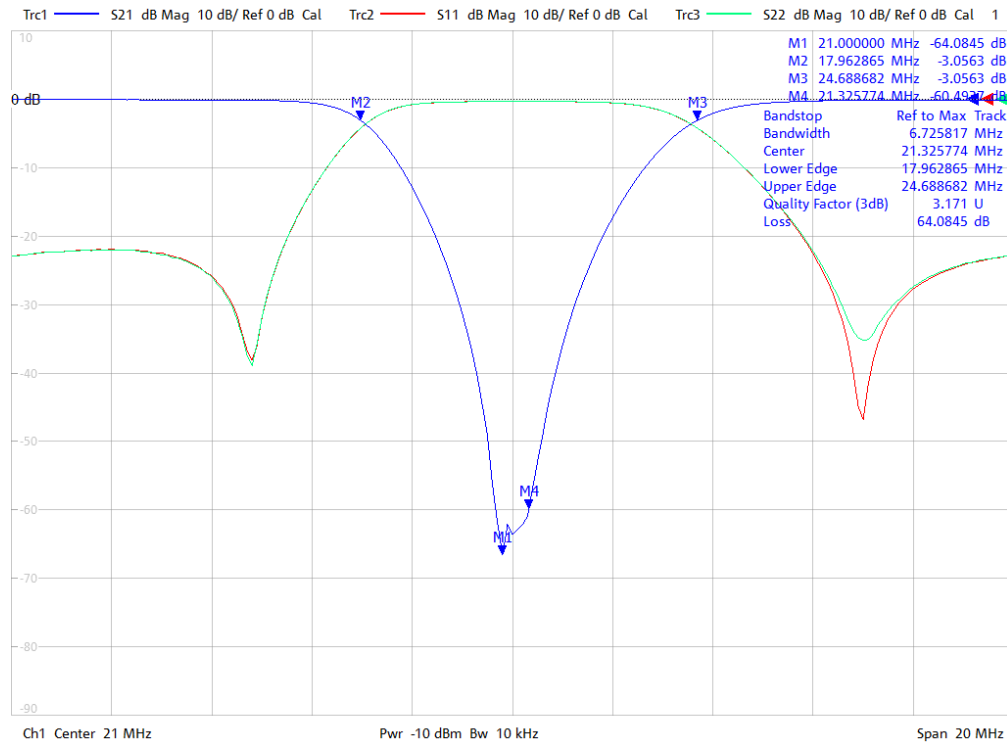

KR Electronics 3434-21-SMA

Specifications

Parameter	Specification	
Filter type	Notch	
Notch Frequency	21 MHz	
Rejection at Notch Frequency	40 dB min	
1 dB Bandwidth	8.1 MHz typical	
3 dB Bandwidth	7.77 MHz max	6.7 MHz typical
20 dB Bandwidth	6.7 MHz typical	
40 dB Bandwidth	1.56 MHz typical	
Source and Load	50 Ω	

Physical Dimensions

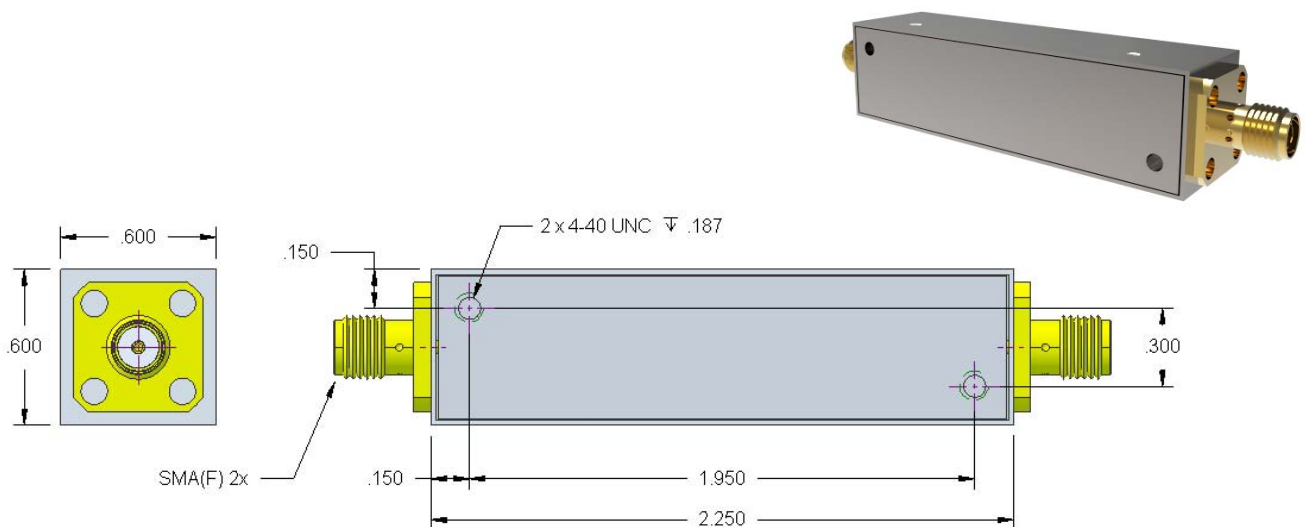

Notes:

1. Dimensions in inches
2. Metal Case
3. SMA(F) Connectors