



THz Scanning Fabry-Perot Interferometer

Terahertz scanning Fabry-Perot interferometer (TSFPI) is designed for measuring wavelength and intensity of narrowband THz radiation. TSFPI may be used with pulsed as well as continuous sources of narrowband THz radiation. TSFPI is comprised of two semi-transparent parallel silicon mirrors, one of those is mounted on a motor-driven linear actuator. Measuring of THz radiation parameters is performed by means of translation (scanning) of the moving mirror as shown in Fig. 1.

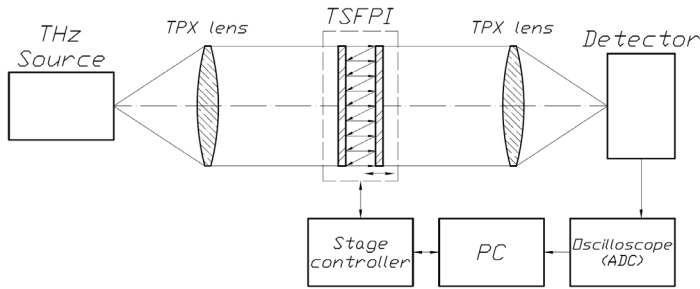
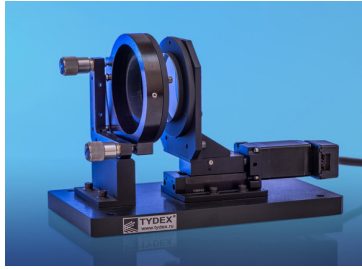

Fig.1 Principal diagram of TSFPI

TSFPI may be used with the following sources:

- gyrotrons;
- optically pumped submillimeter wave lasers;
- backward wave oscillators;
- free-electron lasers;
- difference-frequency THz generators;
- photomixing THz generators;
- quantum cascade lasers;
- p-Ge lasers;
- novel THz sources.

TSFPI is also capable of measuring wavelength and intensity of wideband THz sources, as well as filtering THz radiation as per Fabry-Perot interferometer transmission spectrum (Fig. 2).

TSFPI supports many mirror translation modes, such as moving the mirror into a given position, shifting the mirror for a given distance, continuous and cyclic translation. Mirror translation speed, interval between shifts, starting and ending positions can be adjusted as well.

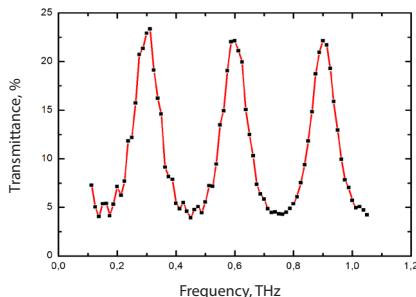

Fig.2 TSFPI transmission spectrum at 500 μm spacing between mirrors as measured by TDS spectrometer Menlo Systems TERA K8

Fig. 3 shows the result of the measurement of lasing wavelength of optically pumped submillimeter wave laser performed by TSFPI. As can

be seen in the diagram, distance between adjacent TSFPI transmission maxima is about 216 μm (433 μm – 216 μm = 217 μm; 647 μm – 433 μm = 214 μm; 865 μm – 647 μm = 218 μm), which corresponds to half the wavelength of the laser. This result agrees with theoretical TSFPI transmittance maxima: $\lambda = 2 * d / m$, where d is the spacing between TSFPI mirrors in μm, m is the interference order, λ is the wavelength being measured in μm.

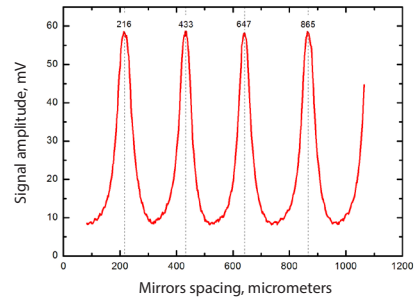

Fig.3 Signal amplitude at optoacoustic detector Tydex GP-1P vs TSFPI mirror spacing. THz radiation is generated by an optically pumped submillimeter wave laser, $\lambda_{las} = 432 \mu m$

Key TSFPI specifications are summarized in Table.

Specification	Value
Operational frequency range, THz	0.1 – 15
Free spectral range, THz	0.01 – 1.8
Spacing between mirrors, mm	0 – 9.5
Spacing setting accuracy, μm	± 1.25
Optical axis height, mm	110
Free aperture, mm	52
Dimensions (LxHxW), mm	232x151x120
Mass, kg	5.0

Key features:

- wide operating range of the TSFPI: 0.1 – 15 THz;
- high breakdown threshold;
- large aperture: 52 mm;
- high accuracy of mirror positioning: ±1.25 μm;
- easy-to-use.

TSFPI package includes the following:

- TSFPI interferometer unit;
- power supply and control unit;
- mirror translation control software;
- cables;
- user guide.

Following accessories for the TSFPI can be supplied additionally:

- optoacoustic detector GC-1P/T/D;
- BPF (band-pass filters) for a specified wavelength within 0.1-15 THz range;
- LPF (low pass filters) to filter out IR radiation, with the following cut-off frequencies: 23.4 THz, 23.3 THz, 23.1 THz, 14.3 THz, 10.9 THz, 8.8 THz, 5.5 THz, 4.3 THz, 4 THz, 3.2 THz;
- a set of attenuators with 1%, 3%, 10% and 30% transmittance;
- TPX and HR FZ-Si lenses.

THz Fabry-Perot Etalon

THz Fabry-Pérot Etalon (TFPE) is a Fabry-Pérot interferometer with fixed distance between reflecting surfaces made of plano-plano plate of high resistivity float zone silicon. The etalon is produced with better flatness and parallelism than a regular plano-plano window. Etalon thickness is measured to a high degree of precision.

General specification:

Material	HRFZ-Si
Type	THz Fabry-Pérot Etalon
Diameter range, mm	25.4-150
Aperture, %	>=90

TFPE is used as a thickness reference when performing calibration of TDS systems, adjustment of narrow-band THz sources and thickness measurements by spectral method in THz frequency range. Also TFPE can be used as a narrow-band filter (slight declination of the etalon allows adjustment of the transmission range).

Usage example

Calibrating TDS system process for precise measurement of sample thickness is an example of TFPE usage. Experimental setup is shown in fig. 1.

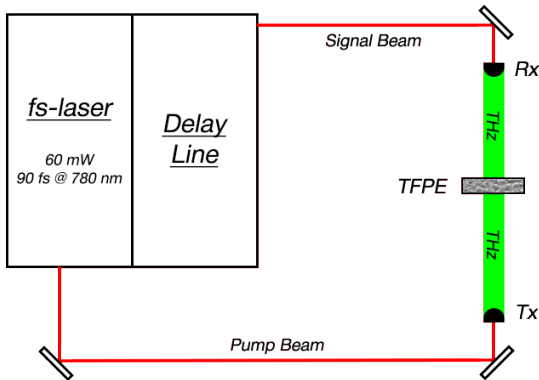

Fig. 1. Experimental setup

The experiment involves measurement of TFPE transmission spectrum and determining the distance between diffraction maxima (fig. 2). Given that distance and the refractive index of HRFZ-Si (3.416) the thickness of TFPE can be calculated.

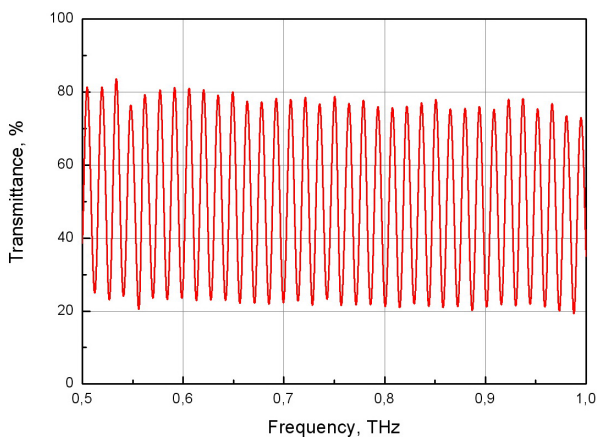

Fig. 2. TFPE transmission spectrum within 0.5 – 1 THz range at thickness 3.042 mm

The measured thickness value is to be the same as stated in the quality certificate. Any discrepancy shows that the TDS system requires adjustment.

Following TFPE are available from the stock:

Part number	Diameter	Rated thickness	Individual etalon parameters			
			Actual thickness*	Free spectral range (FSR)**	Bandwidth (full width at half maximum, FWHM) Δf	Finesse (F)***
	mm	mm	mm	GHz	GHz	-
TEFP-HRFZ-Si-D25.4-T3	25.4	3.0	3.042	14.4	5.5	2.6

*measured for each specific etalon with accuracy of 0.001 mm.

**Free spectral range (FSR) is a frequency offset between longitudinal modes of the TFPE. The free spectral range can be calculated as $FSR = \frac{c}{2nL}$, where c is the speed of light, L is the thickness of the TFPE, n is the refractive index of HRFZ-Si.

***Finesse (F) is the ratio of free spectral range to bandwidth (full width at half maximum, FWHM). The finesse can be calculated as $F = \frac{FSR}{\Delta f} = \frac{2\pi}{-\ln(R^2)}$. Where R is the reflection coefficient of the TFPE.

Please check our Optics stock (THz windows section).

Customer-specified TFPEs can be manufactured on request. Please fill in our Request Form to get a quote.