

## Test Data Sheet

**AM-F0.1R4**  
S/N: GC315

### Resonant electro-optic amplitude modulator

Parameter	Value	Unit
Resonance Frequency*	102	kHz
Preset Frequency	102	kHz
Bandwidth	~50	kHz
Q-factor	~2	
EO crystal	RTP	
Aperture	4x4mm	
Wavefront distortion	$\lambda/8$	
Optical damage threshold (532nm)	100	W/mm <sup>2</sup>
max. RF (stable operation)*	20	V <sub>pp</sub>
AR coating (R<0.5%)	532	nm
Modulation at 532nm	RF <sub>in</sub> =3.6V <sub>pp</sub> for V $\pi$	

\*at 21°C

\*\* no damage with RF<sub>in</sub> < 34V<sub>pp</sub>

# Modulation Performance:

## Measured Amplitude Modulation:

Test Setup:

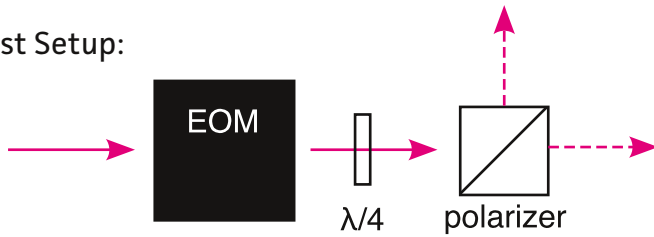

Parameters:

RF Power	$RF_{in}$	4.8	$V_{pp}$
Test wavelength	$\lambda_{test}$	671	nm
Resonance Frequency	$f_0$	102	kHz
Extinction ratio	$r$	140:1	

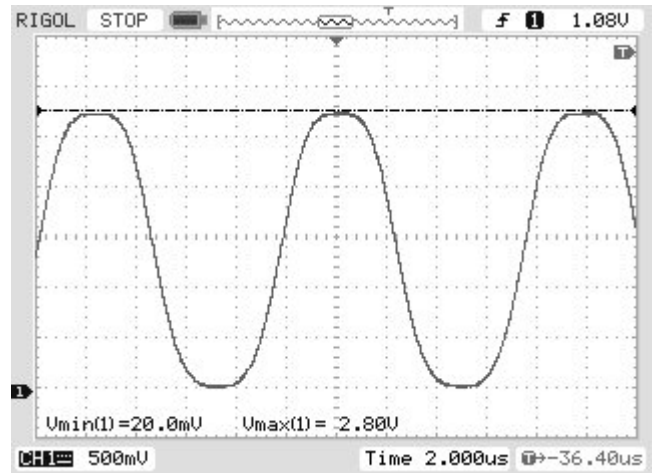

## Wavelength conversion:

wavelength	532	589	1064	nm
$RF_{in}$ for $V\pi$	3.63	4.14	8.10	$V_{pp}$

## Measurement and Theory (compare with manual):

Full-modulation at  $f_0=102\text{kHz}$  ( $4.84V_{pp}$  @ 671nm):

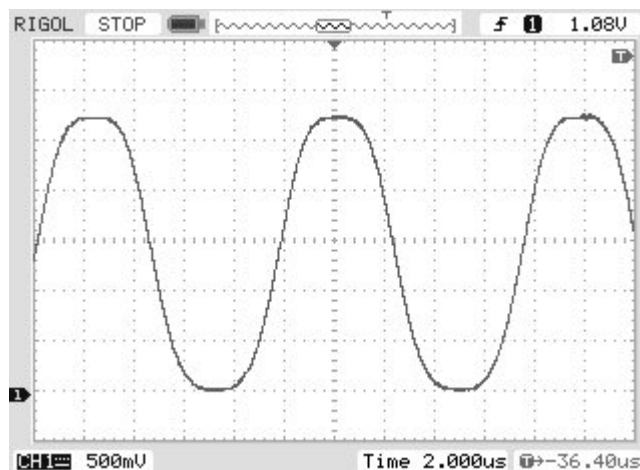
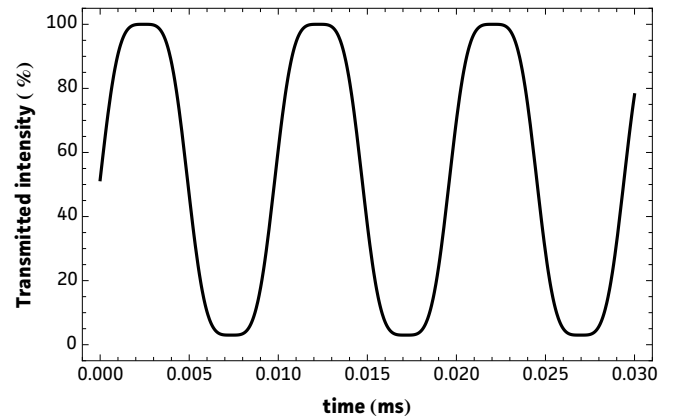
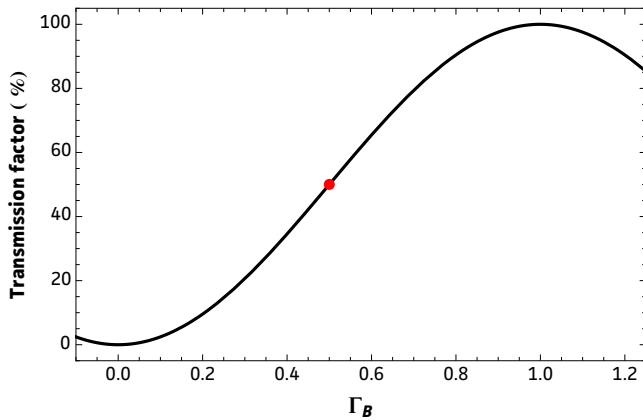

RF = Off:

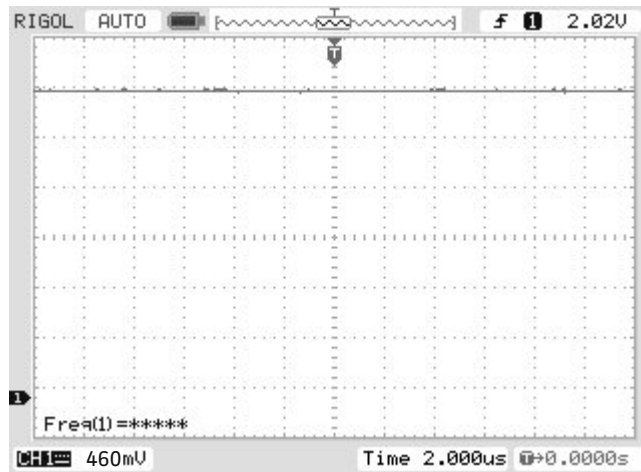
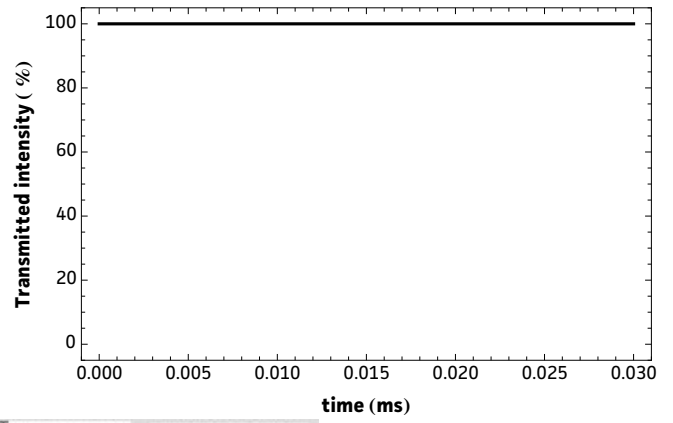
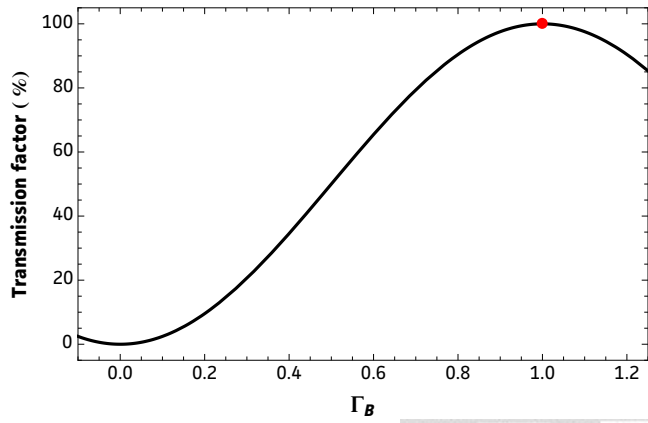

## Return loss and optical modulation:

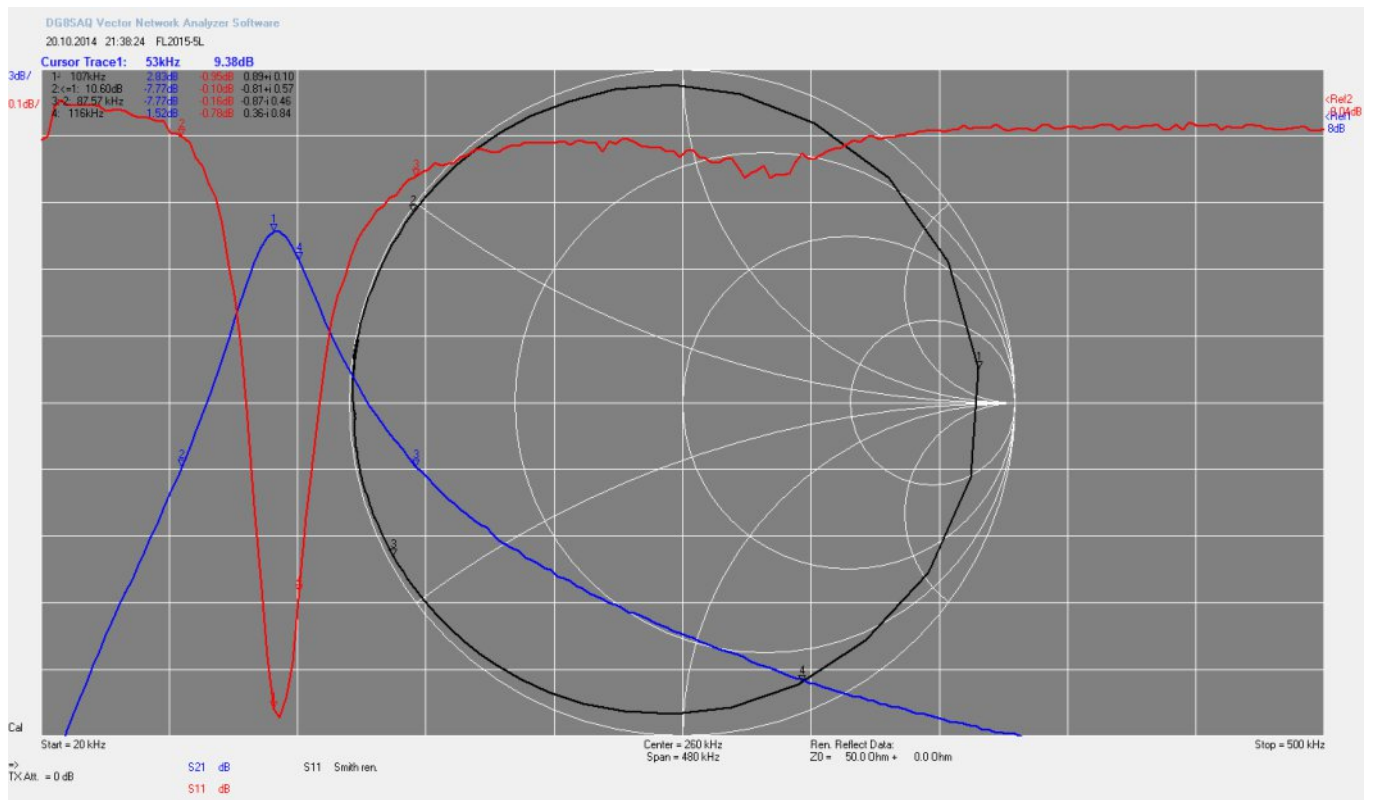
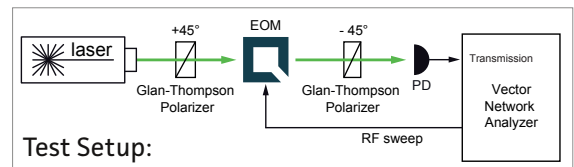
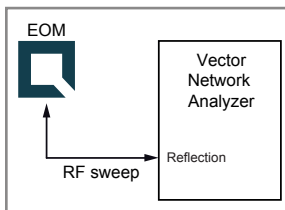

# Package drawing:

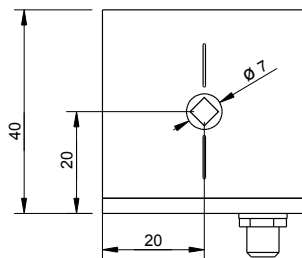
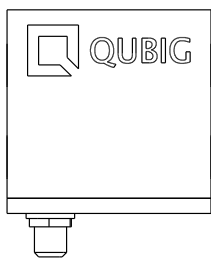
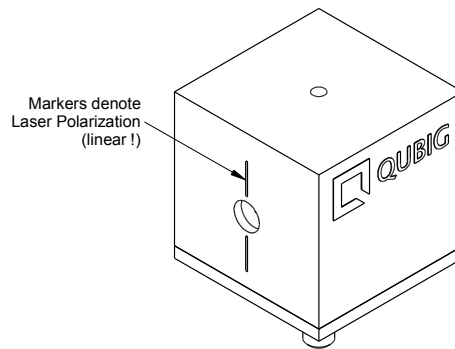
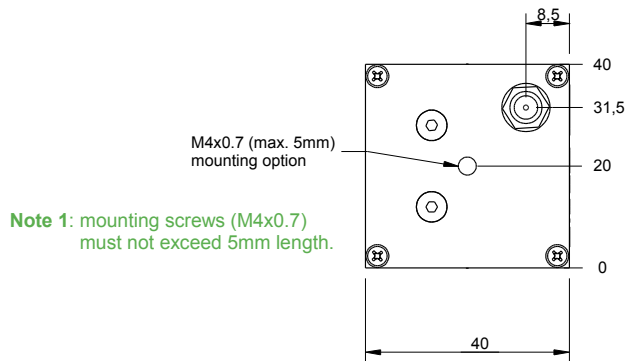

Note 2: crystal aperture is 4x4mm.

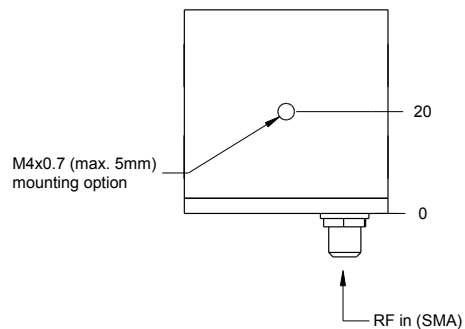

used NTC: NXFT15H103FA2B050

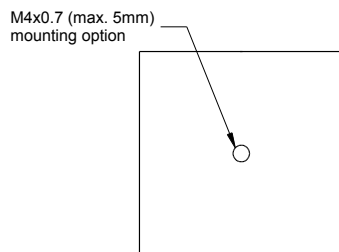
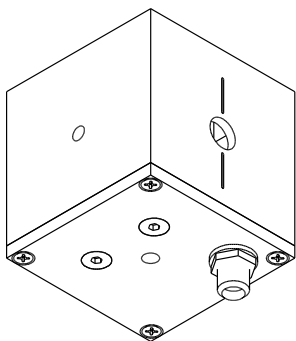

Tested by:

**Qubig GmbH**  
Greimelstr. 26  
83236 Übersee  
Germany

Tel: +49 8642 2449064  
Fax: +49 8642 2447063

eMail: mail@qubig.de  
Web: www.qubig.com