

## HL9479 Resistive Power Divider (DC to 110 GHz)

### Features and Technical Specifications

#### PRODUCT SUMMARY

The HL9479 is an ultra-broadband 6 dB power divider that provides outstanding amplitude- and phase-symmetrical power division from DC to beyond 110 GHz.

This product is designed using a three-resistor network resulting in outputs that are nominally attenuated to 6 dB, and all ports are impedance-matched to 50 Ohms when the ports are terminated.

They are suitable for use in 224 Gbps PAM4 communications systems, high-speed analog-to-digital conversion, frequency response testing for differential devices, and many other applications.

#### DEPLOYMENT NOTES

The ports of the HL9479 are symmetrical and the device can be used in any direction.

#### MODELS & OPTIONS

The following model is available:

**HL9479**, 110 GHz

Bandwidth	DC to 110GHz
Insertion Loss (AC) Maximum See Fig. 1	< 7 dB, DC < f ≤ 50 GHz
	< 8 dB, 50 < f ≤ 85 GHz
	< 9 dB, 85 < f ≤ 110 GHz
Return Loss Typical See Fig. 2	15 dB, DC < f ≤ 50 GHz
	12 dB, 50 < f ≤ 90 GHz
	10 dB, 90 < f ≤ 105 GHz
Amplitude Match Typical See Fig. 1	± 0.2 dB, DC < f ≤ 70 GHz
	± 0.4 dB, 70 < f ≤ 110 GHz
Phase Match See Fig. 4	typ < ± 2°, max < ± 5°, DC < f ≤ 50 GHz
	typ < ± 4°, max ± 8°, 50 < f ≤ 85 GHz
	typ < ± 6°, max < ± 10°, 85 < f ≤ 110 GHz
Rise Time	3 ps
Insertion (Group) Delay	116 ps, all ports
	See Fig. 3
Max Input Power	20 dBm (24 dBm max) <sup>1</sup>
Impedance	50 Ω ± 5%
Connectors	1.0 mm, 3 x jack/female
Dimensions See Fig. 5	1.139" x 0.99" x 0.463"
	28.9 x 25.1 x 11.76 mm
Weight	14 g, (0.49 oz.)
Temperature Limits	-40° to +50° C, operating
RoHS Compliant	Yes, assembled with lead-free solder
REACH Compliant	Yes
Warranty	1 year, see website

1 - Long-term power handling testing is ongoing. The preliminary specification is 20 dBm.



HL9479

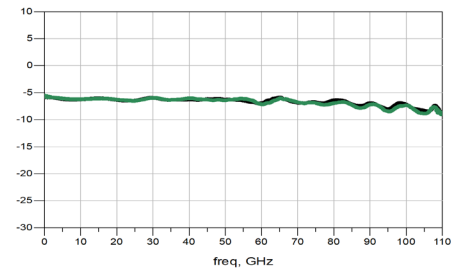

Typical HL9479 Insertion Loss

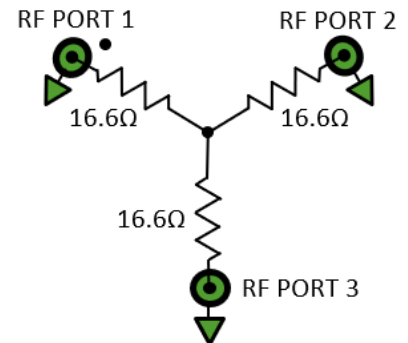

HL9479 Schematic and Port Assignments

## HL9479 Insertion and Return Loss

The HL9479 is matched to 50  $\Omega$  on all ports. Port 1 is specified with a dot on the label, and Ports 2 and 3 are matched.

Figure 1 shows the HL9479 insertion loss and amplitude match on Ports 2-3 to 110 GHz. Figure 2 shows return loss on all three ports of the same device to 110 GHz.

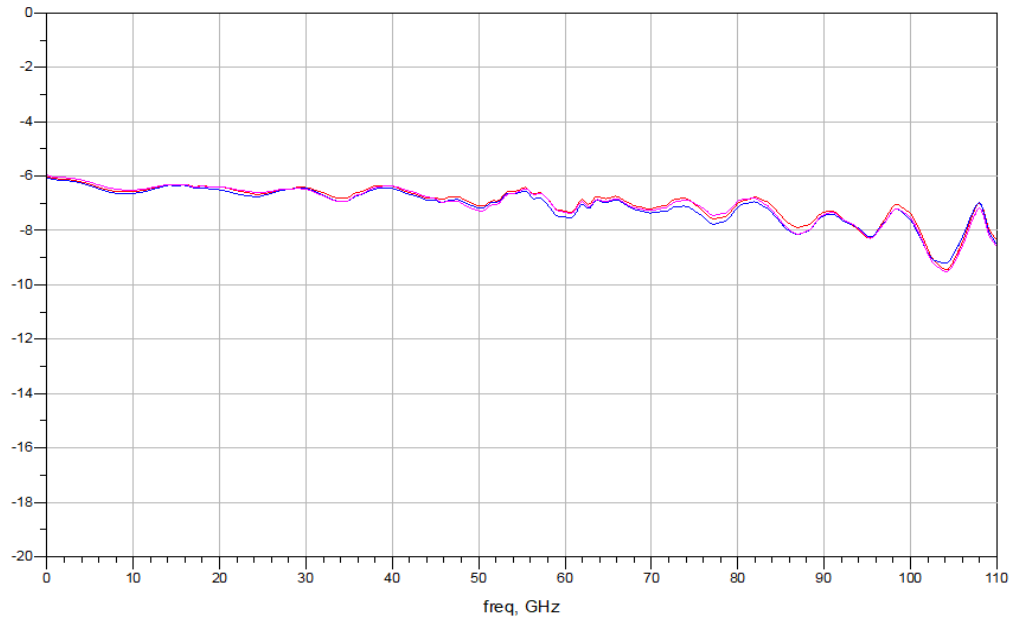

Figure 1: HL9479 Insertion Loss

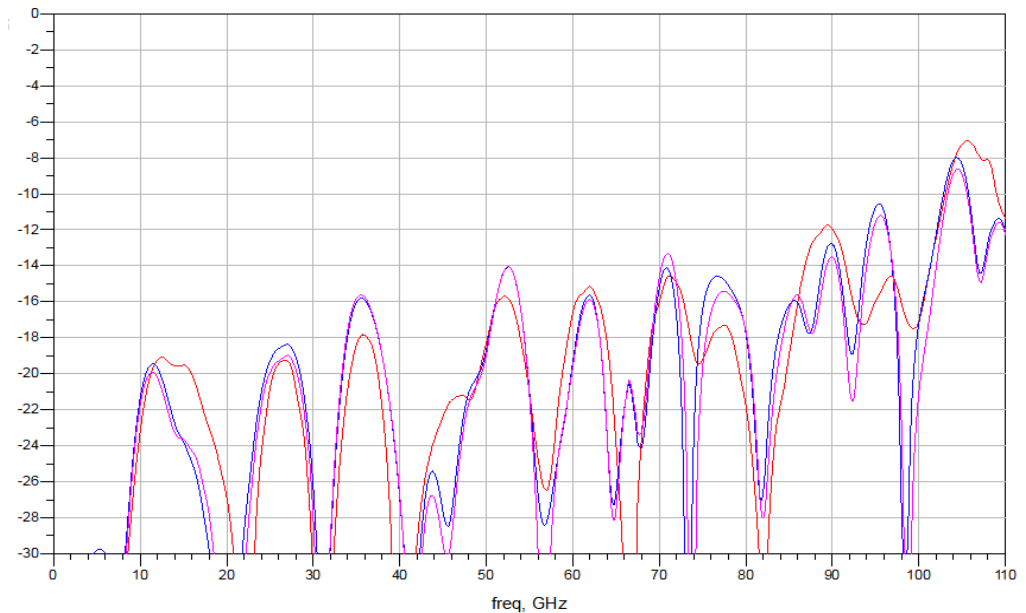

Figure 2: HL9479 Return Loss

## HL9479 Group Delay and Phase Match

Figure 3 shows the typical group delay of an HL9479. The average slope of the phase mismatch, shown in Figure 4, is equal to the group delay mismatch. Other models show similar performance within respective specified bandwidths.

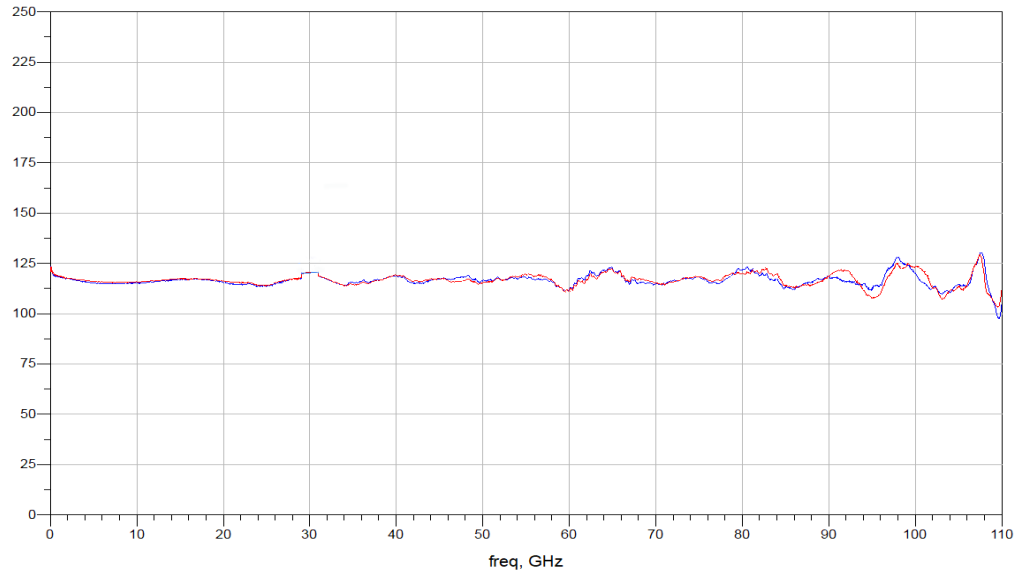

Figure 3: HL9479 Group Delay

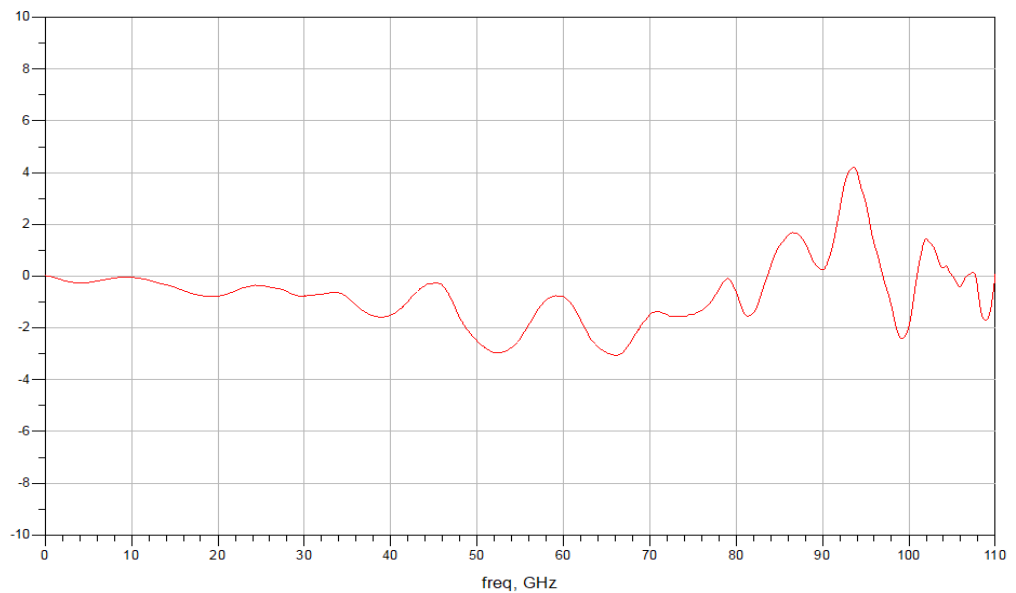

Figure 4: HL9479 Phase Mismatch



## HL9479 Dimensional Drawing

Figure 5 shows a mechanical drawing of an HL9479. Unless otherwise noted, all units are shown in inches. Other models vary in length and width based on connectors.

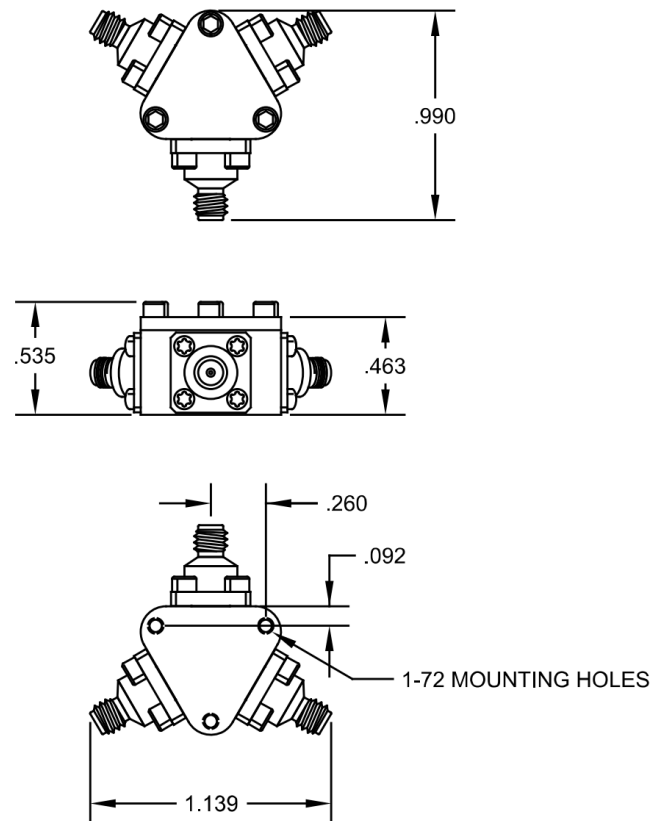

Figure 5: HL9479 Mechanical Drawing