

Fiber-Fiber™ Optical Switch 1x1, Dual 1x1, 1x2



(SM, PM, MM, Broadband, Bidirectional, <0.5ms Fast Switching)

DATASHEET

[Return to the Webpage](#)



Features

- Ultra Low Loss ~0.2dB
- Ultra Broadband
- Little Wavelength Dependence
- Little Temperature Dependence
- Fast <0.5ms
- Vibration Insensitive

Applications

- Laser Systems
- Reconfigurable Optics
- Instrumentations

The FF Series fiber optic switch delivers industry-leading performance with nearly lossless, continuous light transmission without perturbations, ultra-broadband transmission that is limited only by the intrinsic characteristics of the fiber, fast switching times (<1 ms), temperature and vibration insensitive, high on/off ratio, and cost-effectiveness.

This innovative design utilizes direct fiber-to-fiber coupling via a MEMS auto-alignment silicon chip, where the tiny gap (less than 5 microns) between fibers is filled with an index-matching, non-fluorescent liquid, creating an ultra-low-loss continuous optical path without the need for lenses or coatings, thus avoiding surface reflection issues. It is an ideal solution for various applications, especially for spectroscopy, OCT, interferometer, and many other systems that are sensitive to reflections and losses. The FF platform is compatible with all fiber types having a 0.125 mm outer diameter, including single-mode (SM), multimode (MM), polarization-maintaining (PM), double-cladding, bendable, and both large and small core fibers.

The switch is activated via an electrical relay with a latching mechanism, which maintains the optical path even after power is removed. Bidirectional lightpaths are controlled using a 4.5V pulse, with electrical power only consumed during switching.

Specifications

Parameter	Min	Typical	Max	Unit
Wavelength	350		5500	nm
Insertion Loss ^[1]	0.01	0.2	0.4	dB
Wavelength Dependent Loss			0.01	dB
Polarization Dependent Loss			0.05	dB
Polarization Extinction Ratio (PM)	18	25	35	dB
Return Loss	50 (SM)			dB
	35 (MM) ^[3]			dB
Cross Talk	50		75	dB
Optical Rise/Fall Time (PM Fiber) ^[2]	5		20	ms
Optical Rise/Fall Time (SM Fiber) ^[2]	0.2	0.4	0.8	ms
Repetition Rate (PM Fiber)			1	Hz
Repetition Rate (SM Fiber)			5	Hz
Repeatability			± 0.02	dB
Durability	10 ⁸			cycles
Operating Optical Power ^[3]		0.3	0.5	W
Operating Voltage	4.3		4.5	VDC
Operating Current		30	60	mA
Switching Type	Latching / Non-Latching			
Operating Temperature	-40		80	°C
Storage Temperature	-50		90	°C

Notes:

[1]. SM 28 Fiber, Typical loss is 0.3dB. Ultra-low loss 0.1 is special order. Excluding Connectors. For small core fibers the specs are reduced. For IR fluoride fiber loss increase.

[2]. Rise/Fall time is defined as 10/90% optical signal change.

[3]. For 1310/1550nm. The optical power handling rapidly reduces as fiber core size/ reduces. At 650nm the max is 2mW. Expanding the fiber core can increase the power handling.

Legal notices: All product information is believed to be accurate and is subject to change without notice. Information contained herein shall legally bind Agiltron only if it is specifically incorporated into the terms and conditions of a sales agreement. Some specific combinations of options may not be available. The user assumes all risks and liability whatsoever in connection with the use of a product or its application.

Rev 11/30/24

Fiber-Fiber™ Optical Switch

1x1, Dual 1x1, 1x2



(SM, PM, MM, Broadband, Bidirectional, <0.5ms Fast Switching)

DATASHEET

Mechanical Dimensions For PM Fiber (square shape with slow MEMS,) (Unit: mm)

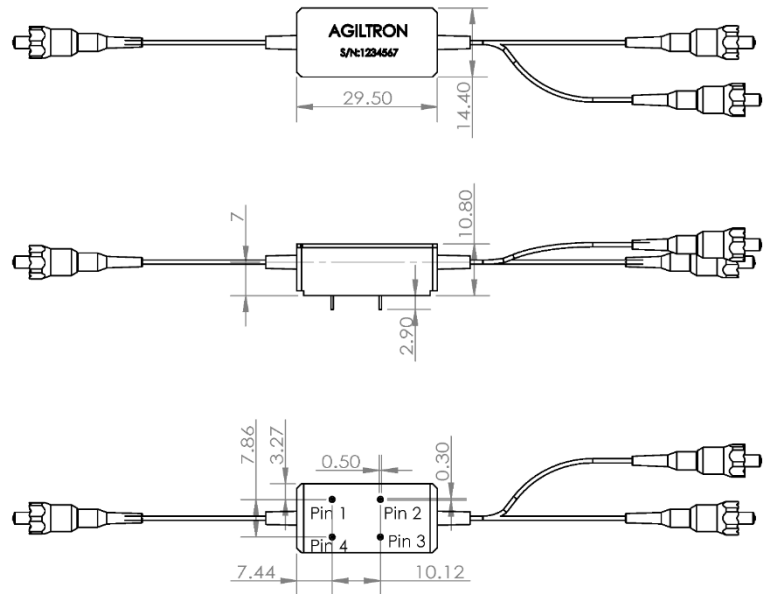

S

Mechanical Dimensions For SM Fiber (T-shape with Fast MEMS,) (Unit: mm)

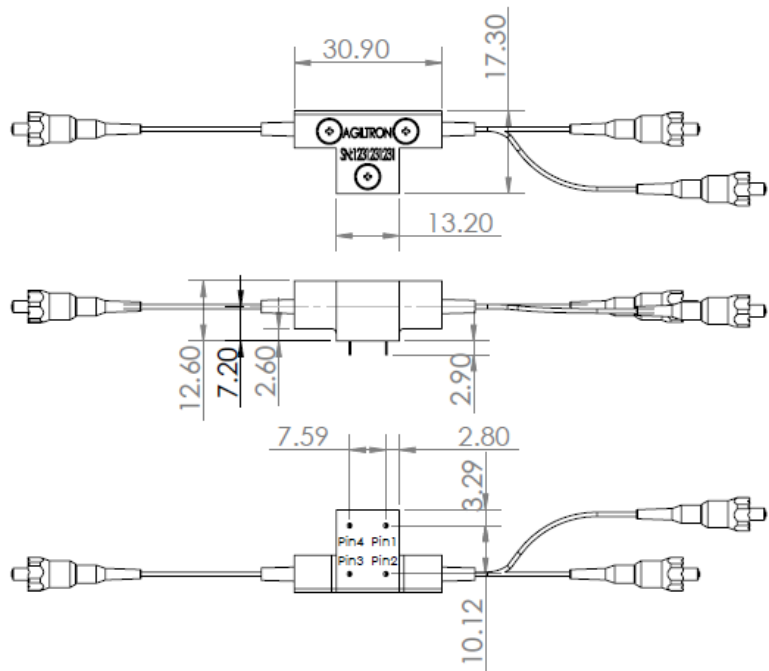

F

*Product dimensions may change without notice. This is sometimes required for non-standard specifications.

Fiber-Fiber™ Optical Switch

1x1, Dual 1x1, 1x2

(SM, PM, MM, Broadband, Bidirectional, <0.5ms Fast Switching)



DATASHEET

Typical Response Speed (SM, Package S)

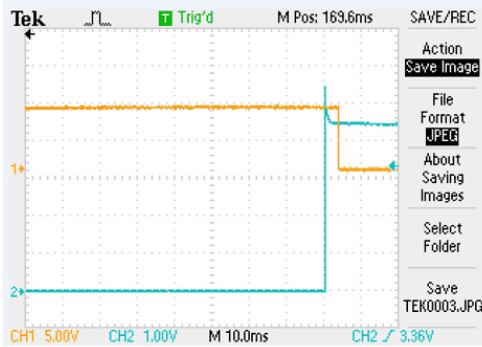
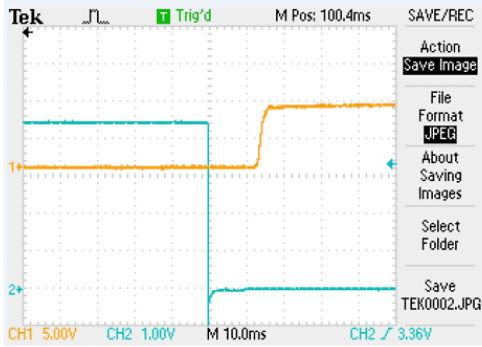

Channel 1 Optical Rise and Fall

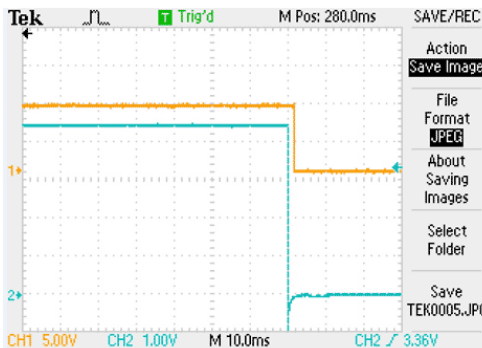
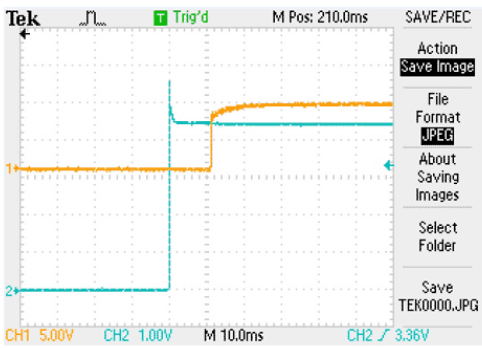

Channel 2 Optical Rise and Fall

Optical Response Speed (SM Package F)

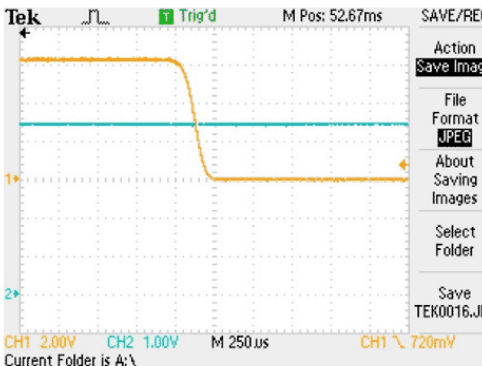
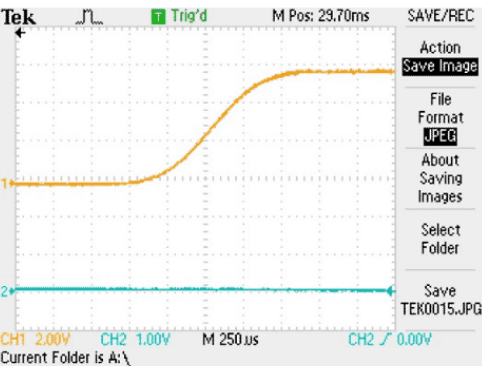

Channel 1 Optical Rise and Fall

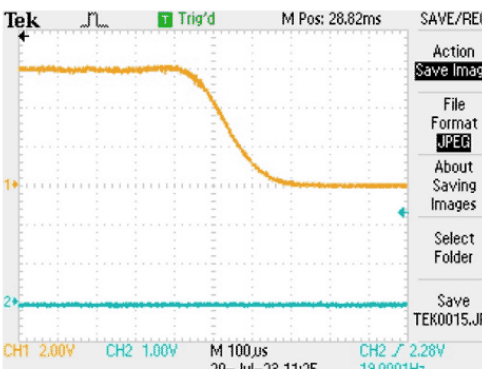
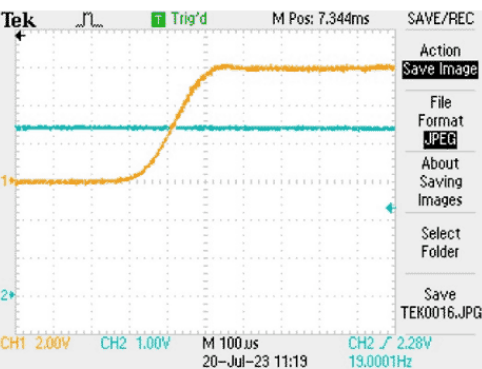

Channel 2 Optical Rise and Fall

Information contained herein is deemed to be reliable and accurate as of the issue date. Photonwares reserves the right to change the design or specifications at any time without notice. Agiltron is a registered trademark of Photonwares Corporation in the U.S. and other countries.

Fiber-Fiber™ Optical Switch

1x1, Dual 1x1, 1x2

(SM, PM, MM, Broadband, Bidirectional, <0.5ms Fast Switching)



DATASHEET

Typical Response Speed (SM Package F)

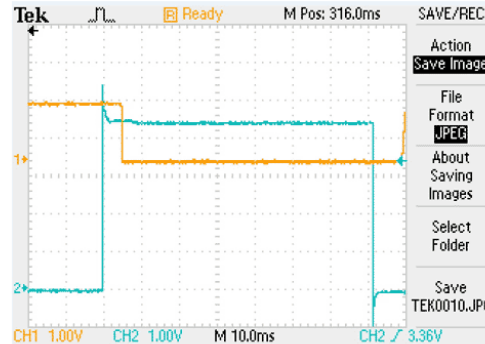
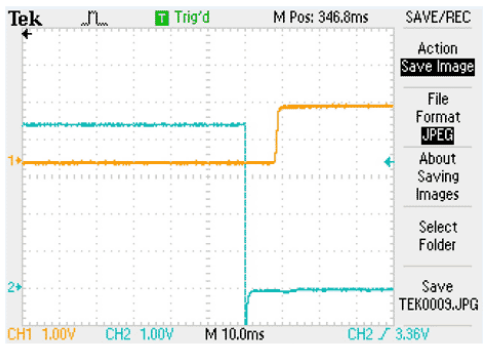

Channel 1 Optical Rise and Fall

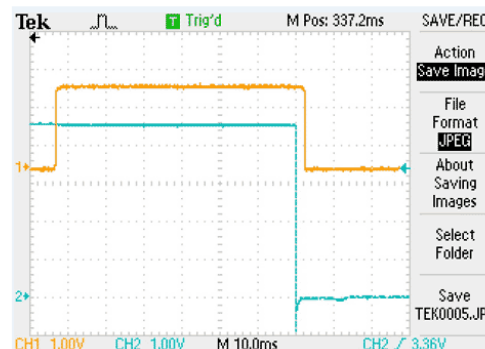
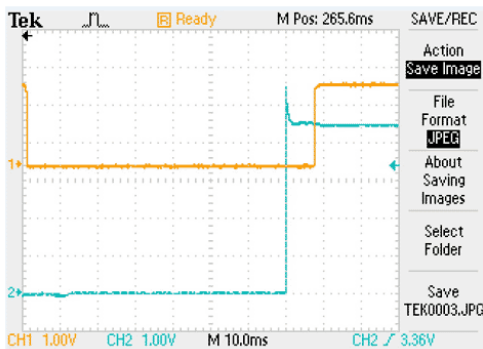

Channel 2 Optical Rise and Fall

Electrical Connector Configurations

Important Note: The device must be driven by the reference circuit. Otherwise, it is not stable. This is because the device contains a permanent magnet inside; thus current must flow in the correct direction to counter the magnet field.

The load is a resistive coil which is activated by applying 4.5V (draw ~ 40mA). The latching switches can also be driven by a pulse mode for energy saving. The switch can withstand 5V which may reduces its durability.

Agiltron offers a computer control kit with TTL and USB interfaces and Windows™ GUI. We also offer RS232 interface as an option.

Latching Type

The activation requires a 4.5V pulse with a duration >15ms

Optical Path	Electric Drive	
	Pin 2	Pin 3
Port 1 → Port 2	4.5V	0V
Port 1 → Port 3	0V	4.5V

Non-Latching Type

Optical Path	Electric Drive	
	Pin 2	Pin 3
Port 1 → Port 2	0V	0V
Port 1 → Port 3	0V	4.5V

Fiber-Fiber™ Optical Switch

1x1, Dual 1x1, 1x2



(SM, PM, MM, Broadband, Bidirectional, <0.5ms Fast Switching)

DATASHEET

Functional Diagram

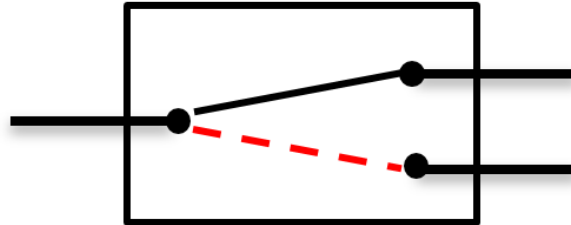

Ordering Information

Prefix	Type	Package	Test Wavelength ^[4]	Fiber Type	Fiber Cover	Fiber Length	Connector
FFSW-	1x1 (Transparent) ^[1] = 11 1x1 (Opaque) = 1D 1x1 (Ultralow Loss) = U1 1x2 Standard = 12 1x2 (Ultralow Loss) = U2 High Power 1x2 ^[2] = H2	Fast Latching ^[3] = 6 Fast Non-Latching = 7 PM Slow Latching = 2 PM Slow Non-Latching = 3	488 nm = 4 360 nm = A 430 nm = B 532 nm = 5 630 nm = 6 780 nm = 7 850 nm = 8 980 nm = 9 1060 nm = 1 1310 nm = 3 1550 nm = C 2000 nm = 2 2.3-4.1 μm = F 3.2-5.5 μm = G	Pick from below table to match the wavelength range	Bare fiber = 1 900um tube = 3 Special = 0	0.25m = 1 0.5m = 2 1.0m = 3 Special = 0	None = 1 FC/PC = 2 FC/APC = 3 SC/PC = 4 SC/APC = 5 ST/PC = 6 LC/PC = 7 Duplex LC/PC = 8 MTP = 9 LC/APC = A LC/UPC = U Special = 0

[1] Transparent: Light passes through without activation. Opaque: Light is blocked in the non-activated state.

[2] The beam size expands approximately 5x within the fiber tip.

[3] Fast latching is available for PM fiber at twice the cost of slow latching.

[4] This ultra-broadband device is limited by the intrinsic transmission of the fiber and is tested at a single selected wavelength. Testing at multiple wavelengths is available under the "special = 0" option at an additional cost, though it may be unnecessary, as fiber transmission data can be referenced directly from the fiber specifications.

Fiber Type Selection Table:

01	SMF-28	34	PM1550	71	MM 50/125μm
02	SMF-28e	35	PM1950	72	MM 62.5μm
03	Corning XB	36	PM1310	73	105/125μm
04	SM450	37	PM400	74	FG105LCA
05	SM1950	38	PM480	75	FG50LGA
06	SM600	39	PM630	76	STP 50/125
07	780HP	40	PM850	77	IRZS23
08	SM800	41	PM980	78	IRZS32
09	SM980	42	PM780		
10	Hi1060	43			
11	SM400	44	PM405		
12		45	PM460		
13		46			

Fiber-Fiber™ Optical Switch 1x1, Dual 1x1, 1x2



(SM, PM, MM, Broadband, Bidirectional, <0.5ms Fast Switching)

DATASHEET

Typical Fiber Transmissions

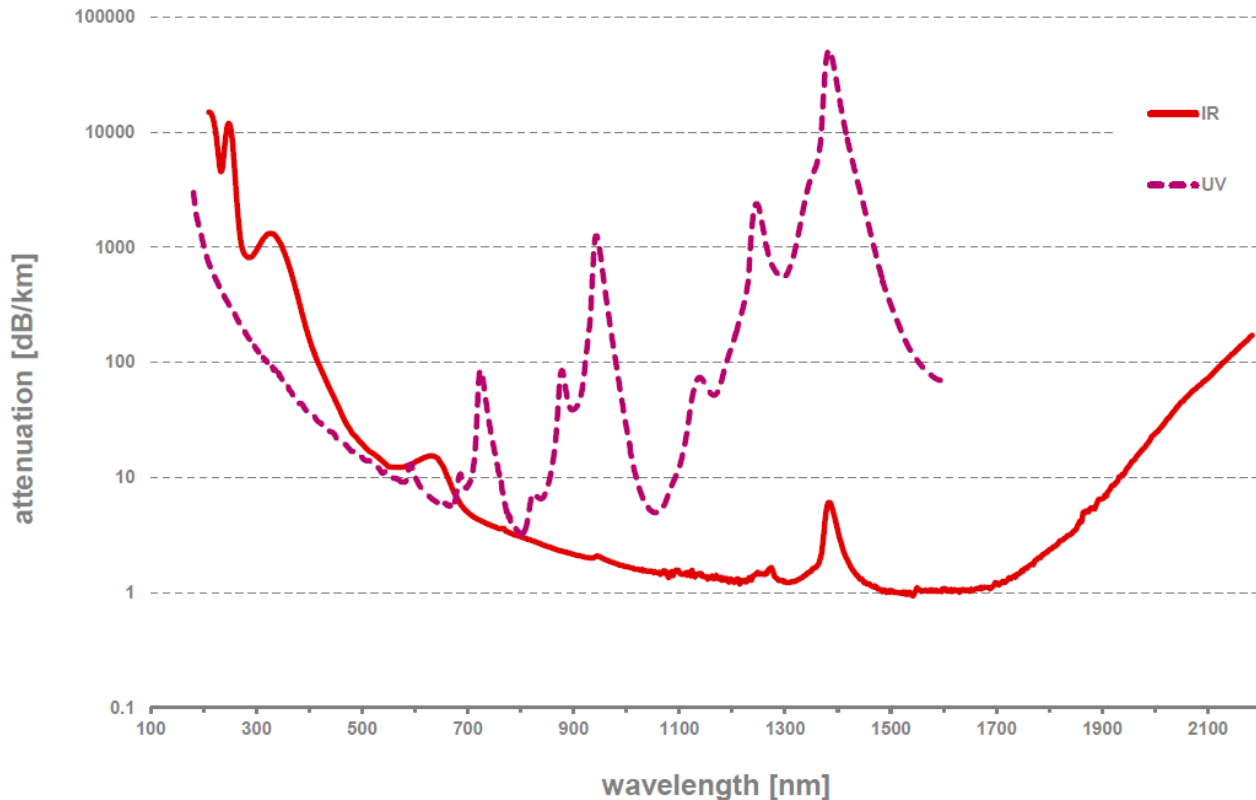

Application Notes

Fiber Core Alignment

Note that the minimum attenuation for these devices depends on excellent core-to-core alignment when the connectors are mated. This is crucial for shorter wavelengths with smaller fiber core diameters that can increase the loss of many decibels above the specification if they are not perfectly aligned. Different vendors' connectors may not mate well with each other, especially for angled APC.

Fiber Cleanliness

Fibers with smaller core diameters (<5 μm) must be kept extremely clean, contamination at fiber-fiber interfaces, combined with the high optical power density, can lead to significant optical damage. This type of damage usually requires re-polishing or replacement of the connector.

Maximum Optical Input Power

Due to their small fiber core diameters for short wavelength and high photon energies, the damage thresholds for device is substantially reduced than the common 1550nm fiber. To avoid damage to the exposed fiber end faces and internal components, the optical input power should never exceed 20 mW for wavelengths shorter 650nm. We produce a special version to increase the handling by expanding the core side at the fiber ends.

Fiber-Fiber™ Optical Switch

1x1, Dual 1x1, 1x2



(SM, PM, MM, Broadband, Bidirectional, <0.5ms Fast Switching)

DATASHEET

Driver Reference Design

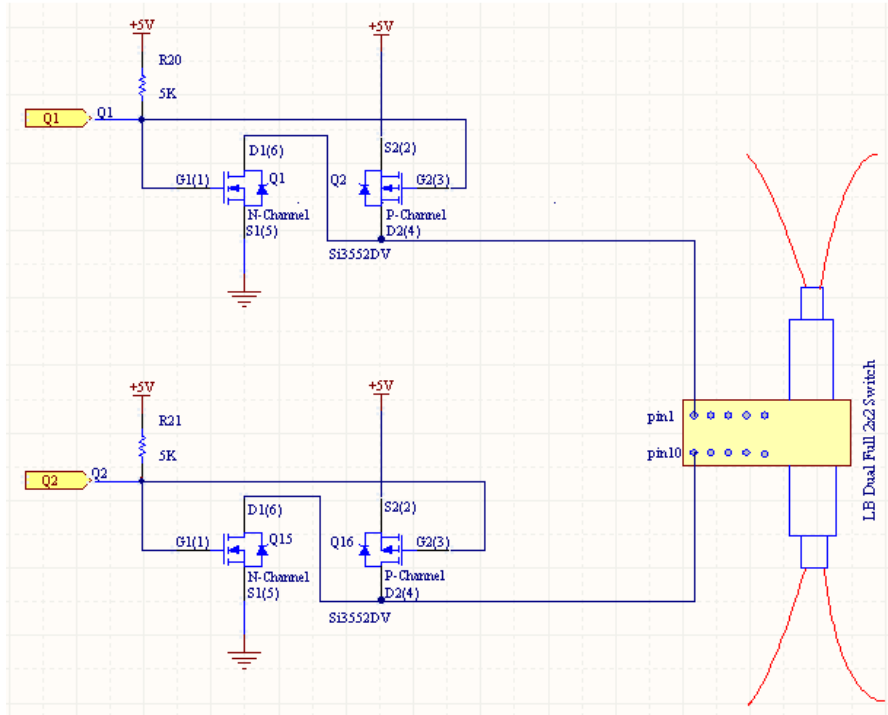

Optical Power Handling vs Wavelength For Single-Mode Fibers

