

1654nm DM LASER

EP1654-DM-B

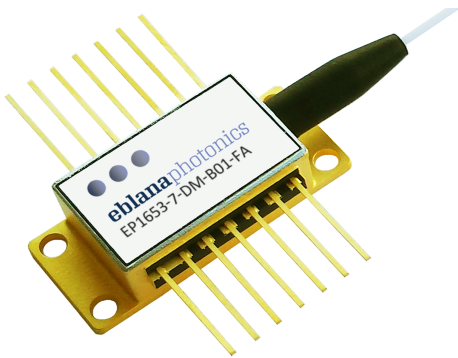

eblanaphotonics



ADVANCED METHANE SENSING

Eblana Photonics EP1654-DM-B laser diode, available in a range from 1640 - 1670nm, is specifically designed for sensitive detection of Methane. Eblana's patented Discrete-Mode (DM) technology enables mode-hop free tuning and excellent SMSR performance, all at a highly competitive price.

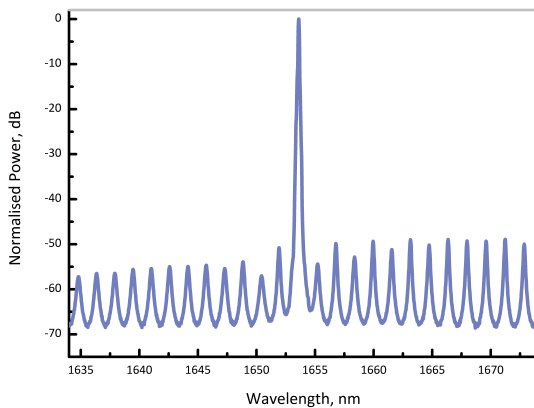

Typical optical spectrum at 25° C

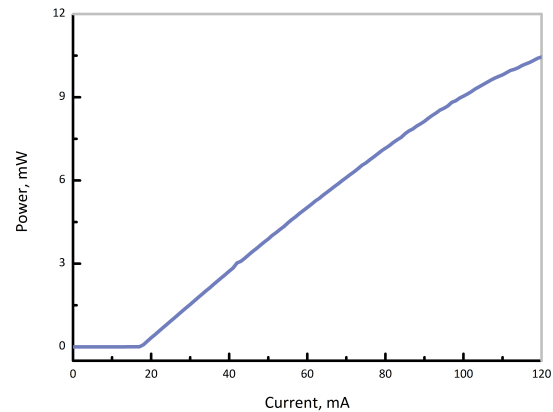

Output power as a function of bias current

ELECTRO-OPTICAL CHARACTERISTICS* ($T_{SUB} = 25^{\circ} C$)

PARAMETER	SYMBOL	MIN	TYP	MAX	UNIT
Available Wavelength Range	λ	1640	1653.7	1673	nm
Wavelength Tolerance	λ_{spec}	$\lambda - 1$	λ	$\lambda + 1$	nm
Side Mode Supression Ratio	SMSR	30	40	-	dB
Threshold Current	I_{th}	-	20	25	mA
Output Power in fiber	P_f	3	6	-	mW
Optical linewidth	Δf	-	-	2	MHz
Temperature Tuning Coefficient	T_{λ}	0.07	0.1	-	nm/°C
Current Tuning Coefficient	I_{λ}	10	15	-	pm/mA
Slope Efficiency	SE	0.05	0.1	-	mW/mA
Thermistor Resistance	R_T	9.5	10	10.5	k Ω
Thermistor Temp. Coefficient	C	-	-4.4	-	%/°C

*CW bias unless otherwise stated

©Eblana Photonics Series 1654-DM-B Rev 2.1



eblanaphotonics

www.eblanaphotonics.com

Sales@eblanaphotonics.com

Dublin, Ireland

ABSOLUTE MAXIMUM RATINGS

PARAMETER	SYMBOL	MIN	MAX	UNIT
Forward Current	I_f	-	120	mA
Forward Voltage	V_f	-	2	V
TEC Current	I_{TEC}	-	1.2	A
Reverse Voltage LD	V_r	-	2	V
Reverse Voltage PD	V_{rev}	-	20	V
Case Temperature*	T_{Case}	-20	65	°C
Chip Submount Temperature	T_{Sub}	0	50	°C
Storage Temperature	$T_{storage}$	-40	85	°C

*For $T_{sub} < 25^{\circ}C$, Max Case Temperature should be derated to $T_{Case,Max} = T_{sub} + 40^{\circ}C$

PACKAGING

The EP1654-DM-B product series is offered in a 14-pin Butterfly package - Inquire for other packaging options. The standard package pinout is shown below, variations may be requested.

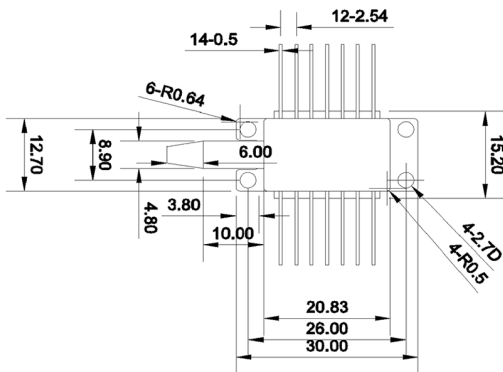

14-pin butterfly schematic

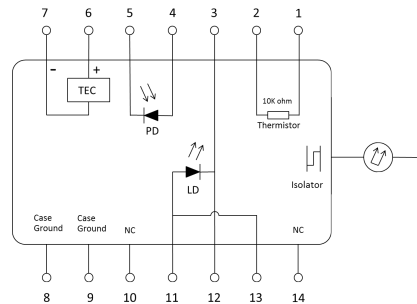

Standard "Pinout 01" option

HOW TO ORDER

Construct your part number using the following example and email your order to sales@eblanaphotonics.com, or call +353 1 675 3228.

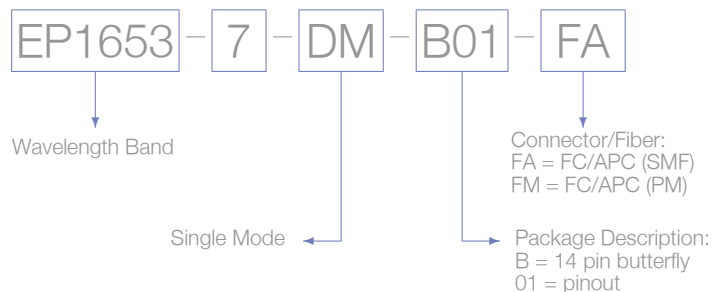

Laser Safety

This is a Class 3R Laser Product as defined by International Standard IEC 60825-1, Edition 3. Invisible Laser radiation is emitted from the end of the fiber or connector. Avoid direct eye exposure to the beam. Laser safety labels are not attached to the module due to space limitations but instead are affixed to the outside of the shipping carton.

©Eblana Photonics 2016. Eblana Photonics Reserves the right to amend this document at any time, without prior warning. ©Eblana Photonics Series 1654-DM-B Rev 2.1

