



## 1 mm (F) to 1 mm (M), High Performance Coaxial Adapter

### Description:

**Model SCT-1F1M-U7** is a high performance 1 mm female to 1 mm male coaxial adapter that covers the frequency range of DC to 110 GHz. This coaxial adapter offers efficient transitioning between the coaxial connectors with a high return loss and a typical insertion loss of 0.6 dB. The impedance of the adapter is 50 Ohms. Other configurations are available under different model numbers.



### Features:

- Instrumentation Grade
- High Return Loss
- Low Insertion Loss

### Applications:

- Test Lab
- Sub-assemblies

### Electrical Specifications:

Parameter	Minimum	Typical	Maximum
Frequency	DC		110 GHz
Insertion Loss		0.6 dB	
Return Loss @ DC to 60 GHz		18 dB	
Return Loss @ 60 to 110 GHz		16 dB	
Impedance		50 Ω	
Specification Temperature		+25 °C	
Operating Temperature	-40 °C		+85 °C

### Mechanical Specifications:

Item	Specification
Connector 1 Type	1 mm Female
Connector 1 Material	Beryllium Copper
Connector 1 Finish	Gold Plated
Connector 2 Type	1 mm Male
Connector 2 Material	Stainless Steel
Connector 2 Finish	Passivated
Weight	0.09 Oz (2.5 Grams)
Length	0.66"
Outline	CT-1F1M-5



## 1 mm (F) to 1 mm (M), High Performance Coaxial Adapter

### Typical Performance vs. Frequency

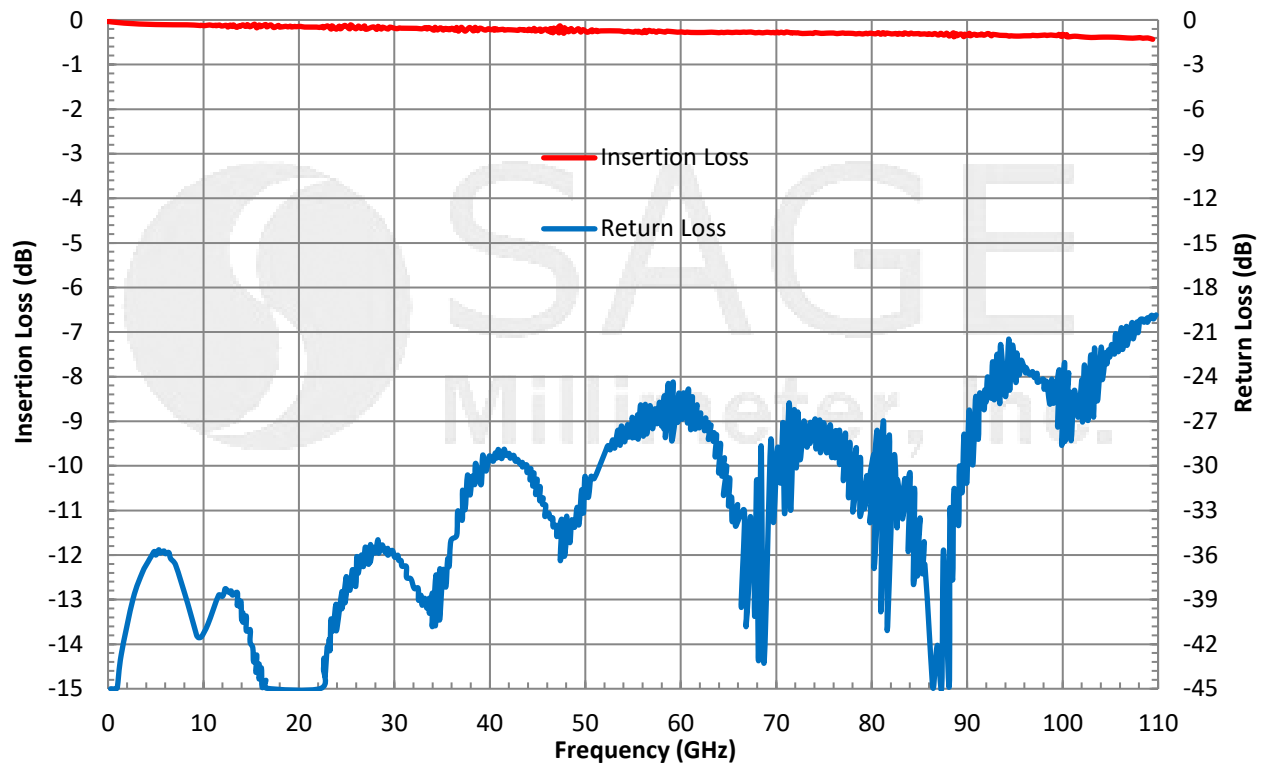

**Mechanical Outline:** (Unless otherwise specified, all dimensions are in inches [millimeters])

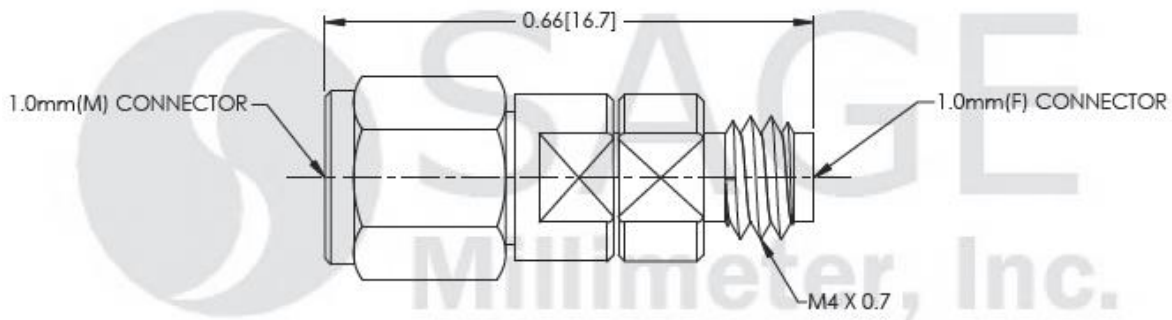

**Note:**

- All data presented is collected from a sample lot. Actual data may vary unit to unit.
- All testing was performed under +25°C case temperature.
- SAGE Millimeter, Inc. reserves the right to change the information presented without notice.

**Caution:**

- Proper torque, 4.0 ± 0.15 inch-pounds (0.45 ± 0.02 Nm), should be used. **SAGE Millimeter torque wrench, model SCH-06004-S1, is highly recommended.**

