



E-Band Mechanically Tuned Gunn Oscillator, ±1.0 GHz Tuning Bandwidth

Description:

Model SOM-76302317-12-S1 is an E-band, mechanically tuned Gunn oscillator that utilizes a high-performance GaAs Gunn diode and proprietary cavity design to deliver +17 dBm typical power. The oscillator features a frequency tuning range of 75 to 77 GHz and delivers low AM/FM noise and harmonic emissions. Compared to its counterparts, such as multiplier-based sources, the Gunn oscillator is a lower cost and cleaner source. The Gunn oscillator's frequency can also be tuned by varying the bias voltage, which is useful for phase-locking and electrical-tuning applications. The Gunn oscillator is equipped with a self-locking set screw for frequency trimming. Models with a micrometer for lab and test bench applications are available under a different model number. The performance of the oscillator can be further enhanced by adding an optional isolator, Gunn oscillator modulator/regulator and temperature heater.



Features:

- Low AM/FM Noise and Harmonics
- Bias Tunable

Applications:

- Test Sources
- Signal Generation
- Lab Test Setups

Electrical Specifications:

Parameter	Minimum	Typical	Maximum
Center Frequency	75 GHz	76 GHz	77 GHz
Power Output		+17 dBm	
Mechanical Tuning Range		±1.0 GHz*	
Bias Tuning Range (+5.2 to +5.8 V _{DC})		±250 MHz	
Bias Voltage		+5.5 V _{DC}	+6.2 V _{DC}
Bias Current		650 mA	
Specification Temperature		+25 °C	
Operating Temperature	0 °C		+50 °C

Note: Actual tuning bandwidth may be wider, ±1.5 GHz typical.

Mechanical Specifications:

Item	Specification
RF Port	WR-12 Waveguide with UG-387/U Anti-Cocking Flange
Bias Port	SMA (F)
Mechanical Tuning	Self-Locking Set Screw
Body Material	Aluminum
Finish	Gold Plated
Weight	3.0 Oz
Outline	OM-SE-A-C





E-Band Mechanically Tuned Gunn Oscillator, ±1.0 GHz Tuning Bandwidth

Typical Measured Data: Bias: +4.5 V_{DC}/750 mA

Tuner Position	Frequency (GHz)	Power (dBm)
1/2 Clockwise	74.93	17.1
Factory Set	76.00	17.0
3/4 Counter Clockwise	77.21	16.8

Mechanical Outline: (Unless otherwise specified, all dimensions are in inches [millimeters])

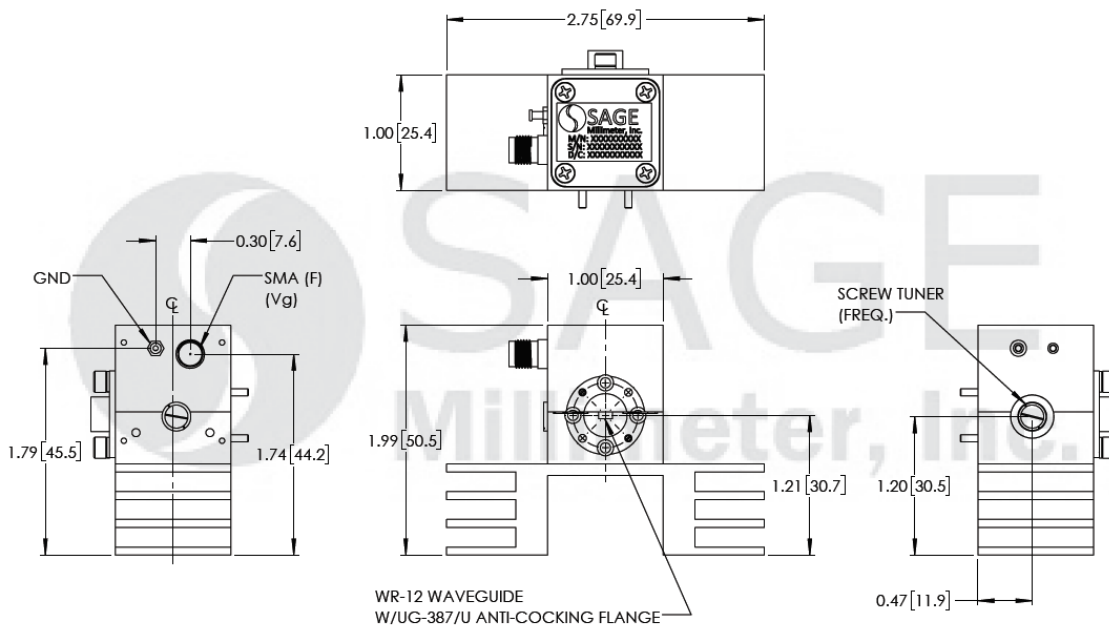

Note:

- All data presented is collected from a sample lot. Actual data may vary unit to unit, slightly.
- The data given above was tested under case temperature **35 °C**.
- The SAGE Millimeter Gunn oscillator regulator **SOR-R3** is highly recommended for over voltage and reverse bias protection. The outline of the model SOR-R3 is shown in below.
- For bias tuning, the regulator can not be used.
- The bias tuning feature can be used for electrical tuning and phase lock loop applications.
- SAGE Millimeter, Inc. reserves the right to change the information presented without notice.





E-Band Mechanically Tuned Gunn Oscillator, ± 1.0 GHz Tuning Bandwidth

Caution:

- Reversing polarity will destroy the device.
- Bias voltage should never exceed **+6.2 Volts**.
- The case temperature of the device should never exceed **+50 °C**. Use an additional heatsink or fan if necessary.
- Proper torque, 8.0 ± 0.4 inch-pounds (0.90 ± 0.02 Nm), should be applied. **SAGE Millimeter torque wrench, model SCH-08008-S1, is highly recommended.**
- Any foreign objects in the waveguide will destroy the device.

Appendix: Outline of Gunn Oscillator Regulator, Model SOR-R3

