

SC5412A

6 GHz Direct IQ Modulator for PXI Express

The SC5412A is a single slot, 3U, PXI express, 400 MHz to 6 GHz direct IQ modulator, upconverting analog In-phase (I) and Quadrature (Q) IF or IQ baseband components directly to RF. The frequency range of the baseband/IF input is from DC to 160 MHz. The module can also be operated as a single stage upconverter. The DC-coupled differential IQ pair may be driven by any dual channel baseband source such as a dual channel arbitrary waveform generator. The local oscillator (LO) is supplied by any external source capable of tuning over the range of the SC5412A (like the SignalCore SC5505A dual channel signal source). The SC5412A can daisy-chain the LO signal, allowing a single source module to drive multiple direct IQ upconverters for coherent transmission.

The SC5412A has an auxiliary RF output port that may be connected to the auxiliary RF input port of SignalCore IQ demodulators such as the SC5312A to aid with system digital equalization that corrects for IQ impairments associated with the device(s). The user can access internal correction DACs, applying compensation offsets to improve the modulator linearity, IP2, and LO feed-through. The input compression-to-noise dynamic range is typically 150 dB with an output signal-to-noise ratio typically at -140 dB. IMD is less than -65 dBc for a -10 dBm output signal.

The SC5412A is designed to be paired with the SC5505A signal source to form a complete RF direct IQ modulator/upconverter solution. It can also be configured with the SC5312A direct IQ downconverter as the core of an RF signal transceiver. The SC5412A's high dynamic range, along with its compact size, low power consumption, and modular flexibility, make it attractive for system integration into applications such as wireless device testing, software define radio research, point-to-point radio, multichannel coherent systems, and other academic and military programs.



Product Features

- RF range 400 MHz to 6 GHz
- DC to 160 MHz baseband
- Output SNR < 140 dB
- Output IMD < -65 dBc
- LO feed-through calibration
- Output range > 90 dB

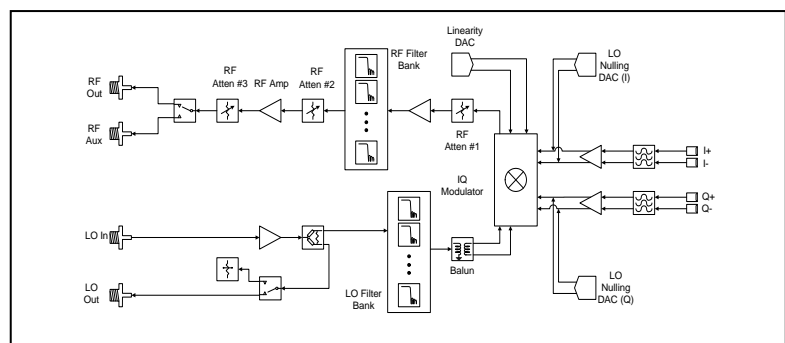

SC5412A Simplified Block Diagram

SC5412A SPECIFICATIONS

TECHNICAL SPECIFICATIONS (AT 25 °C AMBIENT, SINE WAVEFORM)

SPECTRAL SPECIFICATIONS

RF output frequency range 400 MHz to 6 GHz
 IF input frequency DC to 160 MHz

AMPLITUDE SPECIFICATIONS

Output RF range¹ -70 dBm to +10 dBm
 Max IF input 2 V peak
 RF attenuation range 0 to 90 dB
 RF attenuation resolution 0.5 dB
 Gain range -70 dB to +20 dB typical
 Output P1dB compression +15 dBm
 IMD3 (two tones, 1 MHz apart)
 (0.5 V peak baseband)

Frequency	RF = 0 dBm	RF = -10 dBm	RF = 10dBm
900 MHz	-55 dBc	-65 dBc	-40 dBc
1800 MHz	-55 dBc	-65 dBc	-40 dBc
5800 MHz	-44 dBc	-50 dBc	

Output noise density
 (adjusted for IMD3 conditions listed above)

Frequency	RF = 0 dBm	RF = -10 dBm	RF = 10 dBm
900 MHz	-140 dBm/Hz	-150 dBm/Hz	-135 dBm/Hz
1800 MHz	-140 dBm/Hz	-150 dBm/Hz	-130 dBm/Hz
5800 MHz	-135 dBm/Hz	-145 dBm/Hz	

Baseband leakage at RF port < -40 dBm
 LO level Input -3 dBm to +3 dBm

QUADRATURE SPECIFICATIONS

Carrier feed-through (0.5 V baseband)²

Frequency	No Nulling	Nulling
900 MHz	-40 dBc	-63 dBc
1800 MHz	-35 dBc	-60 dBc
3600 MHz	-25 dBc	-60 dBc
5800 MHz	-27 dBc	-55 dBc

Sideband suppression³

Frequency	No Nulling	Nulling
900 MHz	-50 dBc	-65 dBc
1800 MHz	-45 dBc	-65 dBc
3600 MHz	-30 dBc	-65 dBc
5800 MHz	-27 dBc	-60 dBc

TERMINAL SPECIFICATIONS

RF and LO input terminals
 Impedance 50 Ω
 Connector type SMA female
 Coupling AC
 Baseband / IF output terminals
 Impedance (single ended) 50 Ω
 Connector type MCX female
 Coupling DC
 Amplitude 2 V max
 Communication interface PXI Express
 Power consumption +12 V @ 0.5 A
 +3 V @ 0.3 A
 Weight 1 lb
 Dimensions (W x H x D, max envelope) 0.8" x 5.1" x 7.2"
 Warranty 3 years parts and labor on
 defects in materials or workmanship

ADDITIONAL FEATURES

- Auxiliary RF port for calibration use
- Switchable LO output
- DAC control for linearity optimization, and LO feed-through nulling/suppression
- User EEPROM for storage of calibration constants and settings
- Onboard temperature sensor to monitor temperature variation

ORDER INFORMATION

7100032-01 SC5412A, 6 GHz Direct IQ
 Upconverter for PXI Express

Specifications are subject to change without notice. For the most recent product specifications, please visit www.signalcore.com.

Rev 1.0

- (1) Specified for 2.4 GHz, upper range for 5.8 GHz is +7 dBm
- (2) Nulling is performed using onboard calibration DACs, and temperature variation is less than 5 °C from the temperature at which nulling was performed
- (3) Nulling is performed by the user through amplitude and phase compensation of the I and Q data