

SignalCore™

PRESERVING SIGNAL INTEGRITY



Datasheet

SC5507A & SC5508A

DC to 6.25 GHz Signal Generator with Sensor

www.signalcore.com

Table of Contents

1. Definition of Terms.....	2
2. Description	3
3. Frequency Specifications.....	4
4. Amplitude Specifications.....	5
5. Spectral Specifications.....	7
6. Sensor Specifications.....	8
7. General Specifications.....	11
8. Revision Table.....	13

1. Definition of Terms

The following terms are used throughout this datasheet to define specific conditions:

Specification (spec)	Defines expected statistical performance within specified parameters which account for measurement uncertainties and changes in performance due to environmental conditions. Protected by warranty.
Typical Data (typ)	Defines the expected performance of an average unit without specified parameters. Not protected by warranty.
Nominal Values (nom)	Defines the average performance of a representative value for a given parameter. Not protected by warranty.
Measured Values (meas.)	Defines the expected product performance from the measured results gained from individual samples.

Specifications are subject to change without notice. For the most recent product specifications, visit www.signalcore.com.

2. Description

The SC5507A and SC5508A are part of SignalCore's performance signal generator family (PSG), whose frequency range is from True DC to 6.25 GHz, amplitude range is from -50 dBm to 15 dBm (typical) and phase noise is among the lowest in the market. Its unique ability to tune its frequency at 1 mHz resolution down to DC sets it apart from all RF signal generators on the market. Not only does it have fine tuning over a board frequency range, it also has fine step amplitude control of 0.01 dB over more than 65 dB of amplitude range. Its phase noise at 5 GHz is extremely low, < -125 dBm/Hz @10 kHz offset and < -148 dBc/Hz @10 MHz typically.

These devices also feature a power sensor port with frequency response from 1 MHz to 6 GHz, and 45 dB of sensitivity range from -25 dBm to 20 dBm.

The SC5507A and SC5508A are suitable for systems that require high dynamic range and superior spectral purity signal. They are ideal for both analog and digital applications such as LO/modulator sources and high frequency DAC/ADC clocks respectively.

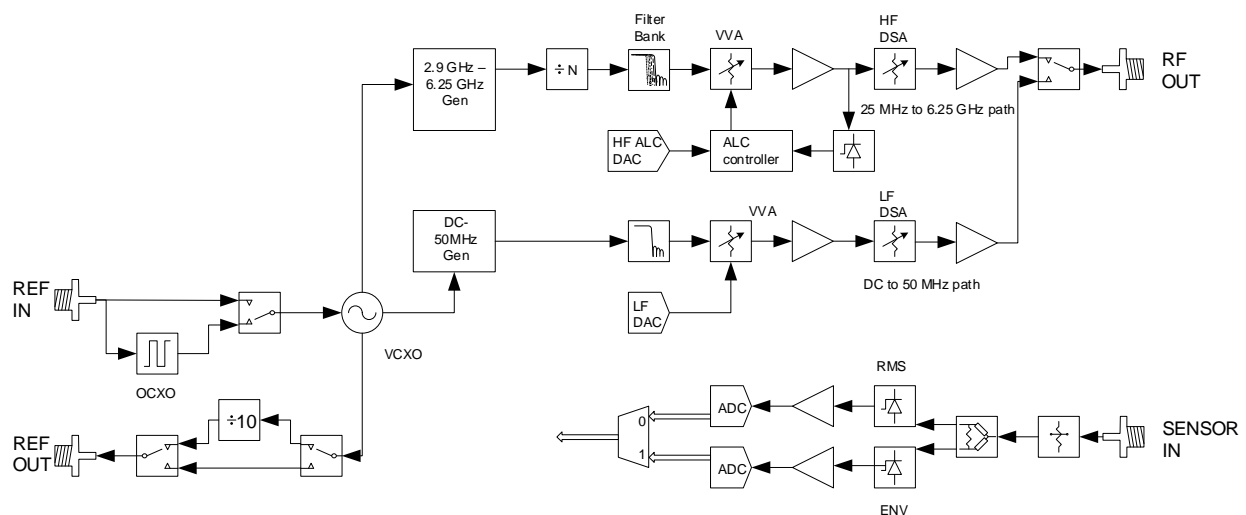

Figure 1. SC5507A/SC5508A Block Diagram

3. Frequency Specifications

RF Output Range		DC to 6.25 GHz
Resolution		0.001 Hz
Switching speed ¹		
Automatic leveling on		< 750 us
Automatic leveling off		< 500 us
List Mode		
Dwell time		0 to 30s
Dwell step		0.5ms
Points	Frequency	2048
	Amplitude	2048
Trigger		Software, External hardware
Frequency Accuracy	Same as accuracy of internal time base or external reference	
Time base accuracy ²		
$\pm [(last\ adjustment\ \times\ aging) \pm temp\ effects \pm cal.\ accuracy]$		
Aging	Daily, after 30 days	$\pm 3\ ppb$
	Yearly	$\pm 0.6\ ppm$
Temp effects	-10 °C to 80 °C	$\pm 20\ ppb$
Init cal. accuracy ³	Calibration precision	$\pm 10\ ppb$
Reference Output		
Amplitude	100 MHz	+ 5 dBm
	10 MHz	+ 5 dBm
Connector		SMA
Impedance	(nominal)	50 Ω
Reference Input		
Frequency		10 MHz
Lock range		$\pm 3\ ppm$
Amplitude	(nominal)	0 to 7 dBm
Connector		SMA
Impedance	(nominal)	50 Ω

¹ On reception of command and settled to final frequency to within 1 ppm.

² Based on the internal 10 MHz OCXO reference.

³ Factory adjustment of the reference DAC with respect to a NIST traceable 10 MHz rubidium clock standard.

4. Amplitude Specifications

Leveled Output Range ⁴	DC to 50 MHz	-50 dBm to 6 dBm
	25 MHz to 5.5 GHz	-50 to +15 dBm
	5.5 GHz to 6.25 GHz	-50 to +12 dBm
Maximum Output ⁵	DC to 50 MHz	+ 7 dBm, typical
	25 MHz to 5.5 GHz	+17 dBm, typical
	5.5 GHz to 6.25 GHz	+13 dBm, typical
Adjustment resolution		0.01 dB, nominal
Absolute level accuracy [ALC closed]		± 0.5 dB (typical)
	DC to 50 MHz	-50 to 6 dBm ± 0.4 dB
	25 MHz to 3 GHz	-20 to max leveled ± 0.65 dB
		-50 to -20 dBm ± 1.0 dB
	3.0 GHz to 6.25 GHz	-20 to max leveled ± 0.8 dB
		-50 to -20 dBm ± 1.5 dB

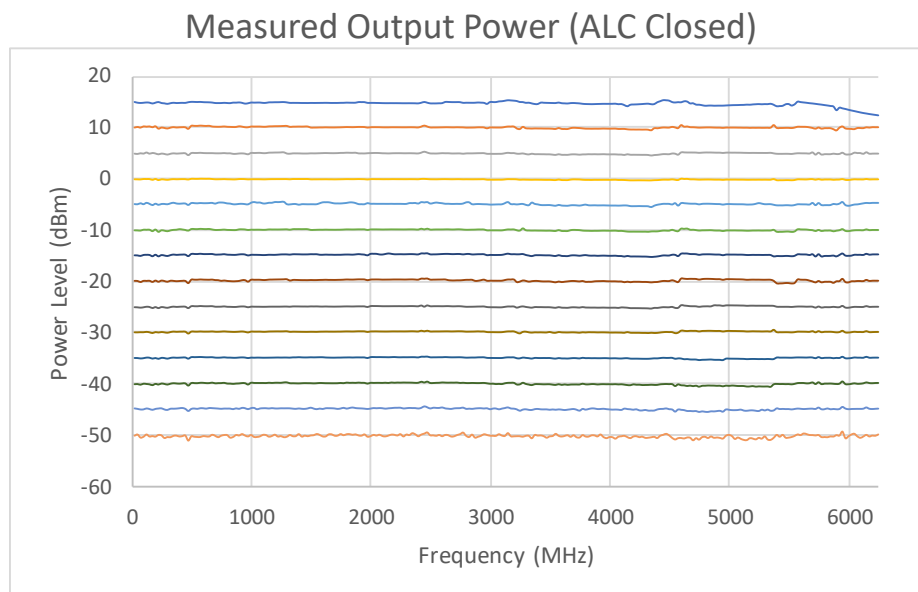

⁴ Leveled range implies that the set amplitude is maintained over the frequency.

⁵ Maximum output is typical and does not guarantee that the value holds true for the frequency range. Typical minimum range is -60 dBm.

Absolute level accuracy [ALC open] ⁶		± 0.5 dB (typical)
DC to 50 MHz	-50 to 6 dBm	± 0.4 dB
25 MHz to 3 GHz	-50 to max leveled	± 1.55 dB
3.0 GHz to 6.25 GHz	-50 to max leveled	± 2.0 dB

Measured Output Power (ALC Opened)

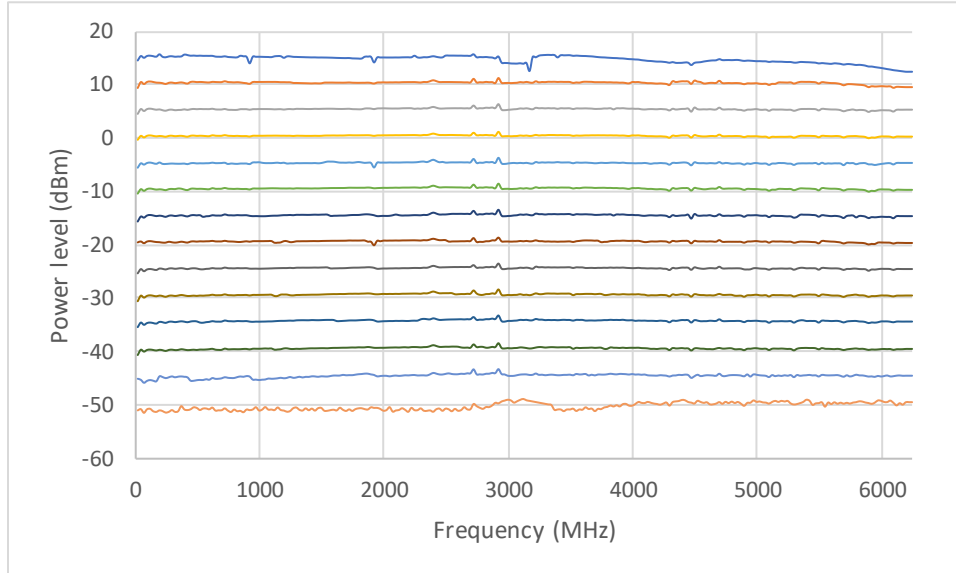

Output voltage standing wave ratio (VSWR)

DC to 2 GHz	< 1.5, nominal
2 GHz to 6.25 GHz	< 2.0, nominal

⁶ Automatic leveling is applied without the control loop closed. This open loop correction may not handle abrupt amplitude transitions well, such as filter band changes. However, this removes leveling dynamics and, in most cases, will improve amplitude settling time.

5. Spectral Specifications

Phase Noise (Normal loop gain)

Offset	RF Frequency							
	100 MHz		1 GHz		3 GHz		6 GHz	
	Typ	max	Typ	max	Typ	max	Typ	max
100	-108	-105	-90	-87	-81	-78	-75	-72
1 kHz	-145	-143	-126	-123	-117	-114	-111	-108
10 kHz	-152	150	-138	-135	-130	-127	-124	-122
100 kHz	-153	-152	-138	-135	-130	-127	-124	-122
1 MHz	-153	-152	-144	-140	-135	-132	-127	-125
10 MHz	-156	-152	-153	-153	-153	-152	-149	-147
Floor	-156	-152	-155	-152	-157	-155	-157	-155

Measured Phase Noise

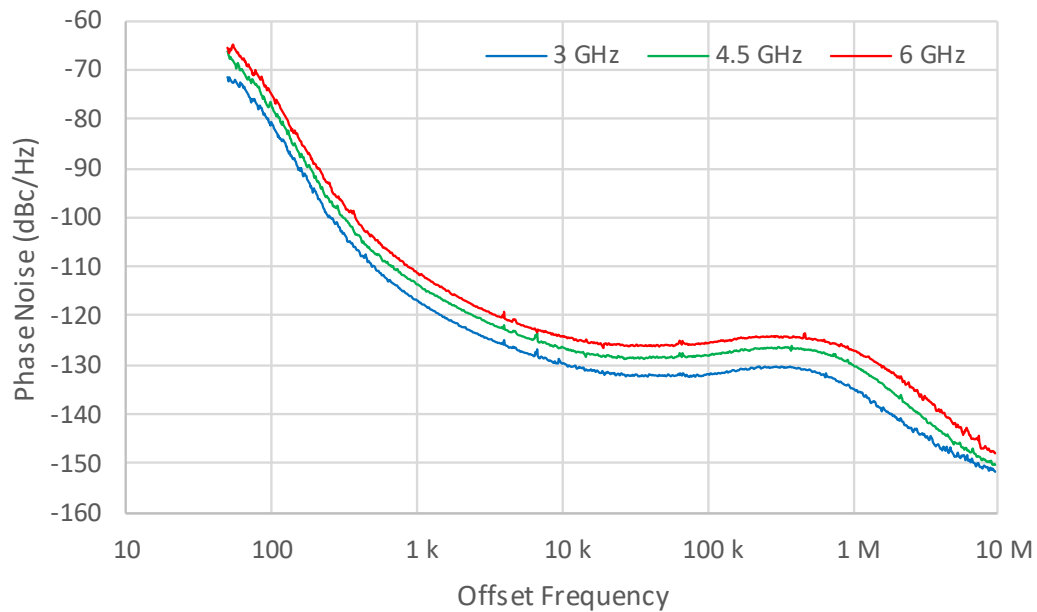

Harmonics

Range ≤ 0 dBm		Range ≤ 10 dBm	
DC to 50 MHz	< -65 dBc	DC to 50 MHz (≤ 7 dBm)	< -55 dBc
25 MHz to 3.0 GHz	< -38 dBc	25 MHz to 3.0 GHz	< -35 dBc
3.0 GHz to 6.25 GHz	< -45 dBc	3.0 GHz to 6.25 GHz	< -27 dBc

Measured 2nd and 3rd order harmonics @ P = 0 dBm

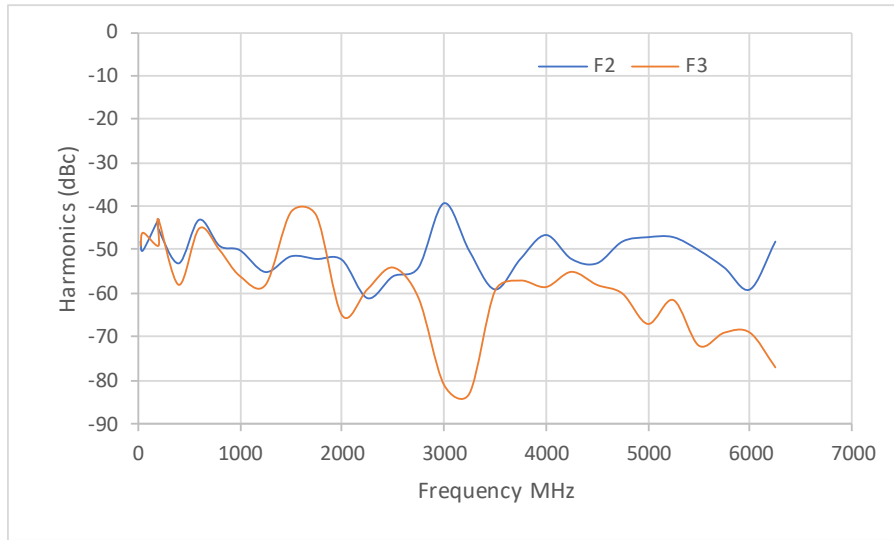

Measured 2nd and 3rd order harmonics @ P = 10 dBm

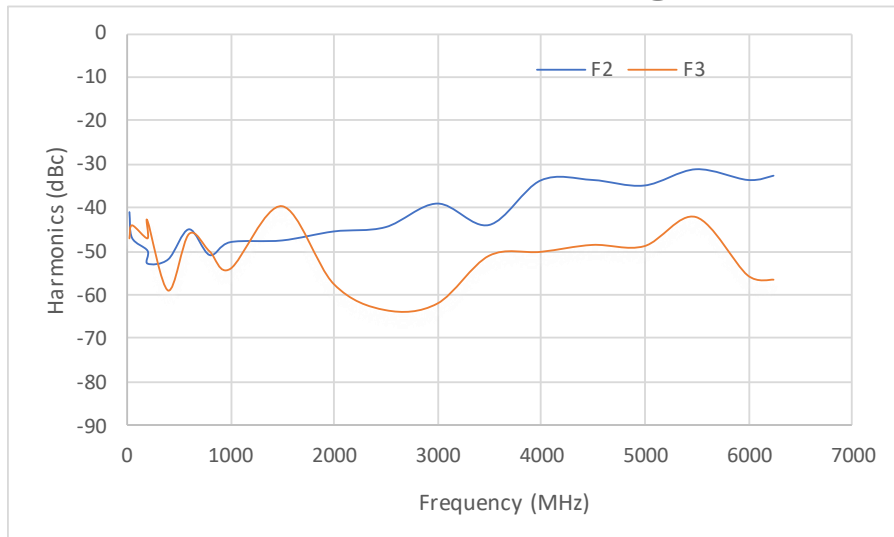

Nonharmonics – close-in spurs ⁷

Frequency	nominal
DC to 50 MHz ⁸	< -75 dBc
25 MHz to 3.0 GHz	< -70 dBc
3.0 GHz to 6.25 GHz	< -60 dBc

Nonharmonics – far-out spurs ⁹

Frequency	nominal
DC to 50 MHz	< -80 dBc
25 MHz to 5.5 GHz	< -75 dBc
5.5 GHz to 6.25 GHz	< -65 dBc

Subharmonics

None

⁷ Close-in non-harmonic spurs include synthesizer spurs, intermodulation products of internal synthesizers, and power supply products for carrier offsets greater than 50 kHz and less than 3 MHz.

⁸ Operating the low frequency generator from DC to 50 MHz; low frequency generator register enabled to extend upper frequency from 25 MHz to 50 MHz.

⁹ Far-out spurs are those that are farther than 3 MHz from the carrier.

6. Sensor Specifications

Frequency	1 MHz to 6 GHz
Amplitude Range	-20 dBm to + 15 dBm
Mode	RMS, Envelope
Acquisition	Single point, averaging

7. General Specifications

Environmental

Internal Device Operating Temperature	SC5508A	-10°C to +75°C
Ambient temperature	SC5507A	0°C to +55°C
Ambient Storage Temperature		-40°C to +100°C
Operating Relative Humidity		10% to 90%, non-condensing
Storage Relative Humidity		5% to 90%, non-condensing
Operating Shock		30 g, half-sine pulse, 11 ms duration
Storage Shock		50 g, half-sine pulse, 11 ms duration
Operating Vibration		5 Hz to 500 Hz, 0.31 g _{rms}
Storage Vibration		5 Hz to 500 Hz, 2.46 g _{rms}
Altitude		Up to 10,000 feet (de-rate max device temperature to 60°C)

Physical

Dimensions (W x H x D, max envelope)		3.7" x 0.75" x 5.75"
Weight		1.0 lb.
Input Voltage		10 to 15 VDC
Current	Peak (initial)	2.7 A max @ 12V
	Steady (average)	1.90 A @ 12V
Power Consumption		24 W max
Communication Interface		PXIe, USB and RS-232 / SPI

Electromagnetic Compatibility (EMC)

This product meets the requirements of the following EMC standards for electrical equipment for measurement, control, and laboratory use:

- EN 61326-1 (IEC 61326-1): Basic immunity
- EN 55011 (CISPR 11): Class A Radiated emissions
- EN 55011 (CISPR 11): Class A Conducted emissions
- EN 61000-4-2: Electrostatic Discharge
- EN 61000-4-3: Radiated Immunity
- EN 61000-4-6: Conducted Immunity
- FCC 15.109: Radiated emissions
- ICES-003: Class A emissions

CE

This product meets the essential requirements of applicable European Directive:

- 2014/30/EU; Electromagnetic Compatibility Directive (EMC)

Warranty 3 years on parts and labor on defects in materials or workmanship.

Revision Table

Revision	Revision Date	Description
0.1	3/14/2019	Document Created
0.2	4/29/2019	Preliminary
0.3	5/2/2019	Added EMC info, corrected harmonics graphs
1.0	9/30/2019	Removed Preliminary
1.1	8/26/2020	Updated formatting. Updated Sensor Specifications.

