

SignalCore™

PRESERVING SIGNAL INTEGRITY



Datasheet

SC5520A & SC5521A UHFS

160 MHz to 40 GHz CW Signal Source

www.signalcore.com

Table of Contents

1. Definition of Terms.....	3
2. Description	4
3. Frequency Specifications.....	5
4. Amplitude Specifications.....	6
5. Spectral Specifications.....	8
6. General Specifications	9
7. Revision Table.....	12

1. Definition of Terms

The following terms are used throughout this datasheet to define specific conditions:

Specification (spec)	Defines expected statistical performance within specified parameters which account for measurement uncertainties and changes in performance due to environmental conditions. Protected by warranty.
Typical Data (typ)	Defines the expected performance of an average unit without specified parameters. Not protected by warranty.
Nominal Values (nom)	Defines the average performance of a representative value for a given parameter. Not protected by warranty.
Measured Values (meas.)	Defines the expected product performance from the measured results gained from individual samples.

Specifications are subject to change without notice. For the most recent product specifications, visit www.signalcore.com.

2. Description

The SC5520A and SC5521A are part of SignalCore's ultra-high frequency synthesizer series (UHFS) of signal sources. It boasts a frequency tuning range of 160 MHz to 40 GHz stepping at 1 Hz resolution, and an amplitude range of -10 dBm to +15 dBm typical, with phase noise among the lowest in the market.

The device features such as wide frequency range, 1 Hz tuning step, better than 20 dB of settable amplitude range, and maximum power typically greater than 15 dBm are packaged into a rugged small form factor, setting it apart from all RF signal generators on the market.

The compact size of the SC5520A and SC5521A makes them optimal modules for system integration, especially in systems that require multiple channels or systems with limited available real estate. These frequency sources are appropriate for applications in communication transceivers, automotive radar and optics, and as clocks in modern day digital data converters.

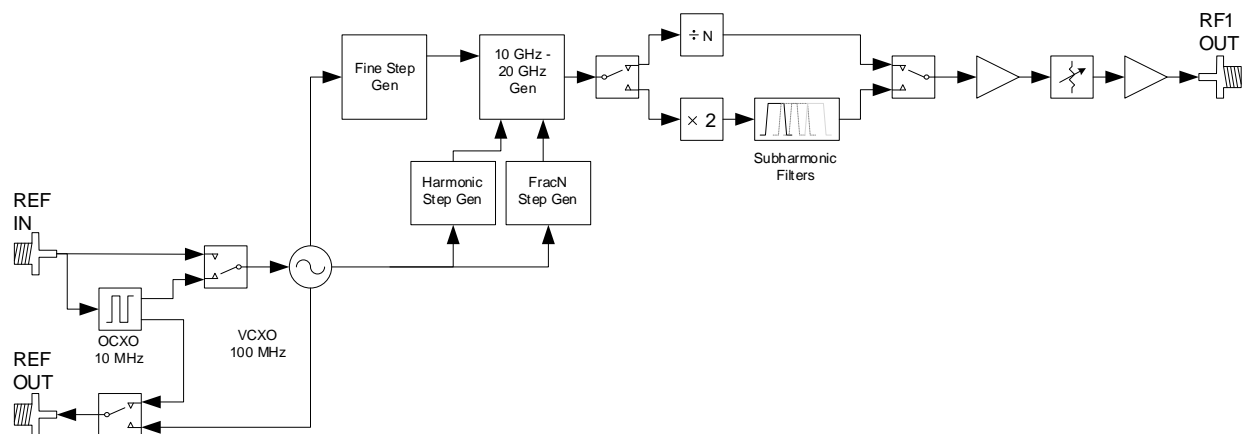

Figure 1. SC5520A/SC5521A Block Diagram

3. Frequency Specifications

RF Output Range ¹		160 MHz to 40 GHz
Resolution		1 Hz
Switching speed		
Automatic leveling on		750 us, typical
Automatic leveling off		500 us, typical
List Mode		
Dwell time		0 to 30s
Dwell step		0.5ms
Points	Frequency	1024
	Amplitude	1024
Trigger		Software, External logic
Frequency Accuracy	Same as accuracy of internal time base or external reference	
Time base accuracy ²	\pm [(last adjustment x aging) \pm temp effects \pm cal. accuracy]	
Aging	Daily, after 30 days	\pm 3 ppb
	Yearly	\pm 0.6 ppm
Temp effects	-10 °C to 80 °C	\pm 20 ppb
Init cal. accuracy ³	Calibration precision	\pm 20 ppb
Reference Output		
Amplitude	100 MHz	+ 3 dBm
	10 MHz	+ 3 dBm
Reference Input		
Frequency		10 MHz
Lock range		\pm 3 ppm
Amplitude	(nominal)	0 to 7 dBm

¹ Tunes from 156.25 MHz to 41 GHz guaranteed by design.

² Based on the internal 10 MHz OCXO reference.

³ Factory adjustment of the reference DAC with respect to a NIST traceable 10 MHz rubidium clock standard.

4. Amplitude Specifications

Leveled Output Range ⁴	160 MHz to 30 GHz	-10 to +15 dBm
	30 GHz to 35 GHz	-10 to +10 dBm
	35 GHz to 40 GHz	-10 to +5 dBm
Maximum Output ⁵	160 MHz to 30 GHz	+ 18 dBm, typical
	30 GHz to 35 GHz	+15 dBm, typical
	35 GHz to 40 GHz	+7 dBm, typical
Adjustment resolution		0.1 dB, nominal
Absolute level accuracy		± 1.0 dB (typical)
	160 MHz to 10 GHz	± 0.65 dB
	10 GHz to 20 GHz	± 0.75 dB
	20 GHz to 30 GHz	± 1.0 dB
	30 GHz to 40 GHz	± 1.5 dB

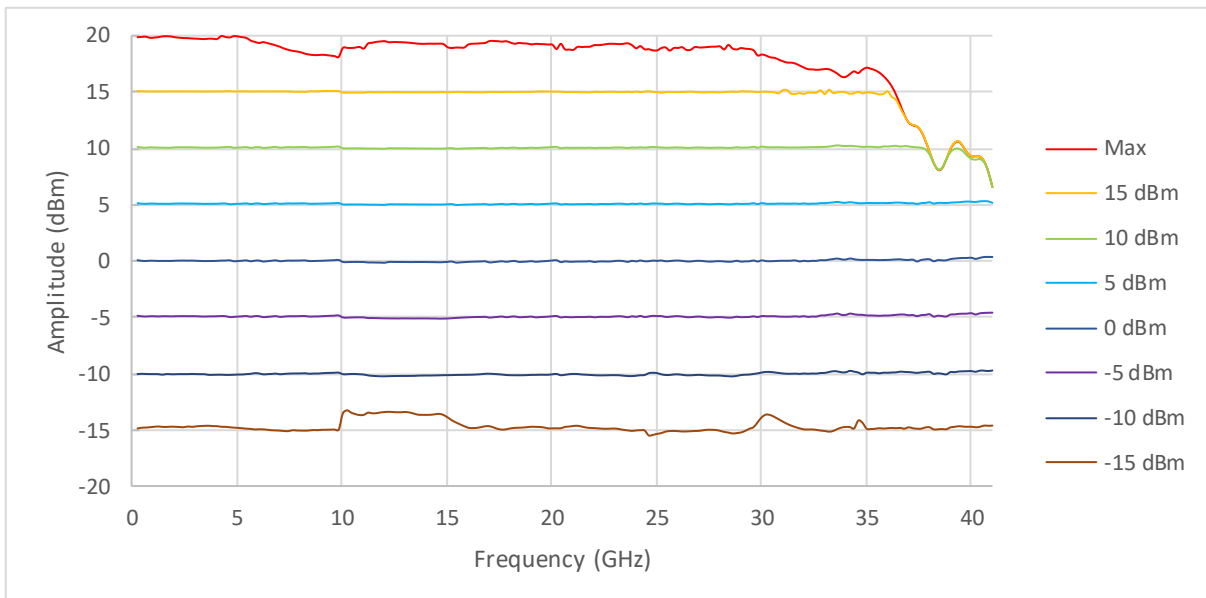

Typical measured output power

⁴ Leveled range implies that the set amplitude is maintained over the frequency band.

⁵ Maximum output is typical and does not guarantee that the value holds true for the frequency range. The minimum output level is < -10 dBm.

Output voltage standing wave ratio (VSWR)

160 MHz to 10 GHz	< 1.8, typical
10 GHz to 20 GHz	< 2.3, typical
20 GHz to 30 GHz	< 2.6, typical
30 GHz to 40 GHz	< 2.8, typical

On/Off Ratio	> 60 dBc
---------------------	----------

5. Spectral Specifications

Phase Noise (Normal loop gain, dBc/Hz)

Offset	RF Frequency							
	1 GHz		10 GHz		18 GHz		30 GHz	
	Typ	max	Typ	max	Typ	max	Typ	max
100	-82	-79	-64	-60	-60	-56	-55	-50
1 kHz	-125	-121	-105	-100	-100	-95	-96	-98
10 kHz	-136	-132	-118	-112	-115	-110	-109	-105
100 kHz	-137	-132	-118	-112	-115	-110	-109	-105
1 MHz	-134	-129	-116	-110	-114	-110	-108	-104
10 MHz	-150	-147	-132	-129	-130	-125	-125	-120
Floor	-153	-147	-152	-146	-152	-146	-146	-141

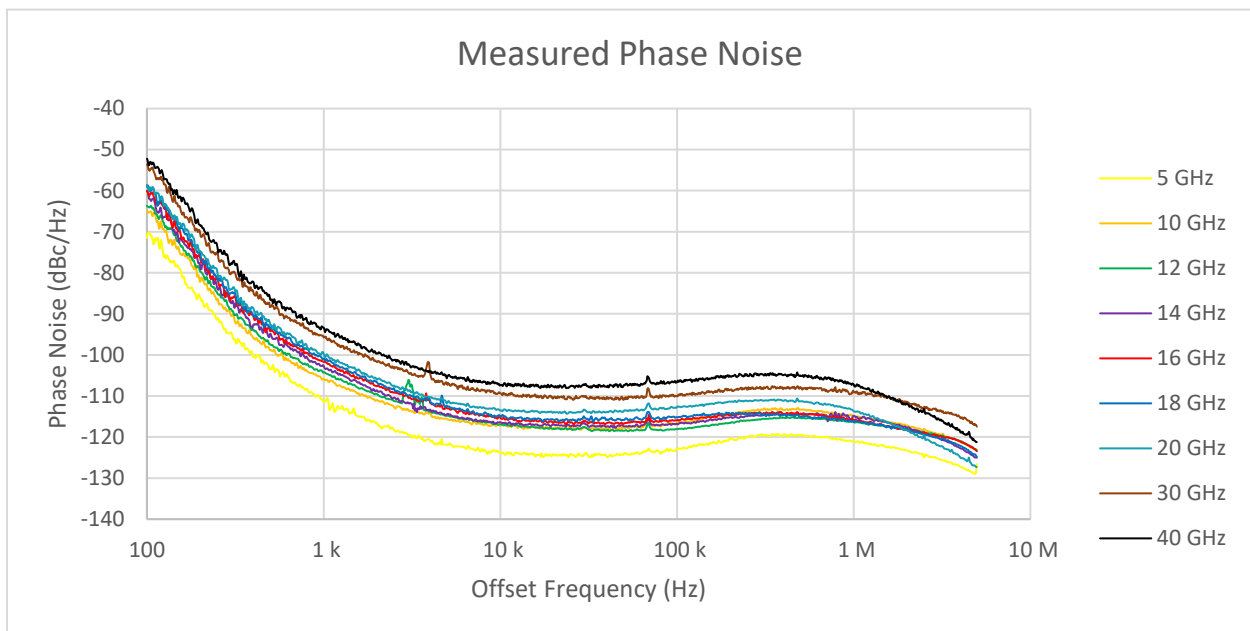

Harmonics	160 MHz to 15.0 GHz	< -10 dBc
	15.0 GHz to 20.0 GHz	< -20 dBc
	20.0 GHz to 40.0 GHz	< -30 dBc
Subharmonics	160 MHz to 20 GHz	< -80 dBc typical
	20 MHz to 40.0 GHz	< -40 dBc typical

Measured Harmonics and Sub-harmonics @ P = 0 dBm

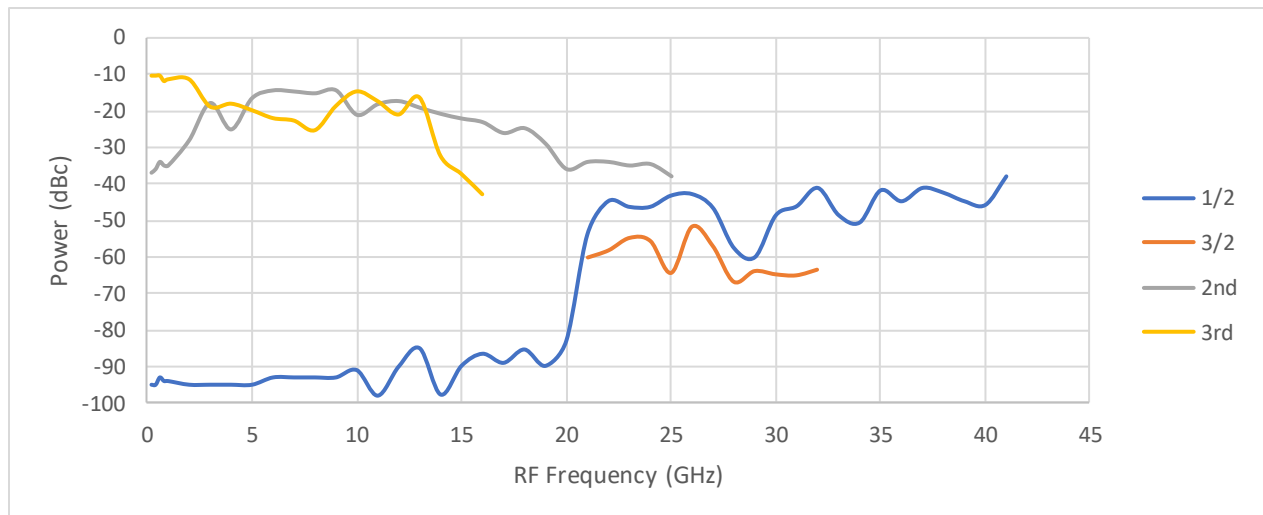

Nonharmonics

Frequency	Close-in Spurs		Far-out Spurs	
	nominal	max	nominal	max
160 MHz to 5.0 GHz	< -75 dBc	< -65 dBc	< -75 dBc	< -70 dBc
5.0 GHz to 10.0 GHz	< -70 dBc	< -60 dBc	< -70 dBc	< -65 dBc
10.0 GHz to 20.0 GHz	< -65 dBc	< -55 dBc	< -65 dBc	< -60 dBc
20.0 GHz to 40.0 GHz	< -55 dBc	< -45 dBc	< -60 dBc	< -50 dBc

6. General Specifications

Environmental

Internal Device Operating Temperature	SC5520A	-10°C to +75°C
Ambient temperature	SC5521A	-10°C to +55°C
Ambient Storage Temperature		-40°C to +100°C
Operating Relative Humidity		10% to 90%, non-condensing
Storage Relative Humidity		5% to 90%, non-condensing
Operating Shock		30 g, half-sine pulse, 11 ms duration
Storage Shock		50 g, half-sine pulse, 11 ms duration
Operating Vibration		5 Hz to 500 Hz, 0.31 g _{rms}
Storage Vibration		5 Hz to 500 Hz, 2.46 g _{rms}
Altitude		Up to 10,000 feet (de-rate max device temperature to 60°C)

Physical

Dimensions (W x H x D, max envelope)	SC5521A	3.7" x 0.75" x 5.75"
	SC5520A	Single PXI Slot
Weight		1.0 lb.
RF Output Connector		K-type, 2.92 mm
Reference Connectors		SMA
PXI Backplane Clock Connector	SC5520A	MCX
RF Connector Nominal Impedance		50 W
Power and digital Interface Connector	SC5521A	TFM-115-01-L-D-RA
Communication Interface		PXIe, USB and RS-232 / SPI
Input Voltage	SC5521A	10 to 15 VDC
	SC5520A	5V, 12V
Current	Peak (initial)	2.7 A max @ 12V
	Steady (average)	1.85 A @ 12V
Power Consumption		24 W max

Electromagnetic Compatibility (EMC)

This product meets the requirements of the following EMC standards for electrical equipment for measurement, control, and laboratory use:

- EN 61326-1 (IEC 61326-1): Basic immunity
- EN 55011 (CISPR 11): Class A Radiated emissions
- EN 55011 (CISPR 11): Class A Conducted emissions
- EN 61000-4-2: Electrostatic Discharge
- EN 61000-4-3: Radiated Immunity
- EN 61000-4-6: Conducted Immunity
- FCC 15.109: Radiated emissions
- ICES-003: Class A emissions

CE

This product meets the essential requirements of applicable European Directive:

- 2014/30/EU; Electromagnetic Compatibility Directive (EMC)

Warranty 3 years on parts and labor on defects in materials or workmanship.

7. Revision Table

Revision	Revision Date	Description
0.1	12/14/2018	Document Created
0.2	7/12/2019	Preliminary
0.3	12/5/2019	Added EMC info
0.4	12/20/2019	Pre-release Review
0.5	12/22/2019	Pre-release
1.0	01/02/2020	Release
1.1	03/12/2020	Revised amplitude parameters
1.2	04/22/2020	Grammatical Edits
1.3	08/25/2020	Fixed some formatting. No content changes.
1.4	10/09/2020	Updated phase noise

