

## Galvanometer Motor

- **Motor structure:**

The galvanometer motor contains a high-precision sensor and a motor part based on moving magnet technology. The motor rotor is optimized for excellent dynamic properties and response characteristics. In addition, the motor features high rigidity and low friction. Moreover, each motor is matched to a certain inertia mirror through the kinematics and dynamics simulation.

- **Ultra-Galvo Motor:**

Configured photoelectric sensor as feedback, it has high repeatability and linearity with high cost performance ratio.

- **Extra-Galvo Motor:**

Configured grating encoder as position feedback, it has higher position resolution, better repeatability and lower drift compared with photoelectric galvanometer. Even if under the temperature variation, it maintains good repeatability.

### Sensor comparison

	Ultra-Galvo Motor	Extra-Galvo Motor
Maximum angle (°)	±12.5	±12.5
Nonlinearity (%)	<0.4	<0.1
Repeatability (μrad)	<2	<1
Offset Drift (μrad/K)	<15	<15
Gain Drift (ppm/K)	<50	<8
Position resolution	18 Bit	23Bit

Note:

- ① All angles are in mechanical degrees
- ② After conversion ,18 bit corresponds to 1.7 μrad,and 23 bit corresponds to 0.05μrad

# Ultra-Galvo Motor



## Technical Parameters

Ultra-Galvo Motor	XXXS	XXS	XS	S	M	L	XL
Input Beam Aperture (mm)	<7	7	8.5	10	14	20-30	50-80
Moment of inertia(g·cm <sup>2</sup> )	0.013	0.018	0.174	0.34	1.2	5.1	14.3
Force constant(N·mm/A)	1.2	2.7	5.3	7.5	15	24	35
Coil resistance(Ω)	2.1	3.6	2.1	2.7	2.6	1.58	0.9
Coil inductance(μH)	35	70	63.5	165	275	300	343
Maximum continuous current(A)	2.3	2.3	2.3	2.5	3.5	5	7
Peak current(A)	6	8	10	10	10	10	10
Rise Time(ms)	0.13	0.10	0.15	0.18	0.3	0.7	1.5
Weight(g)	13	18	50	220	300	400	460

## TECHNICAL DRAWING

UltraGalvo < 7mm

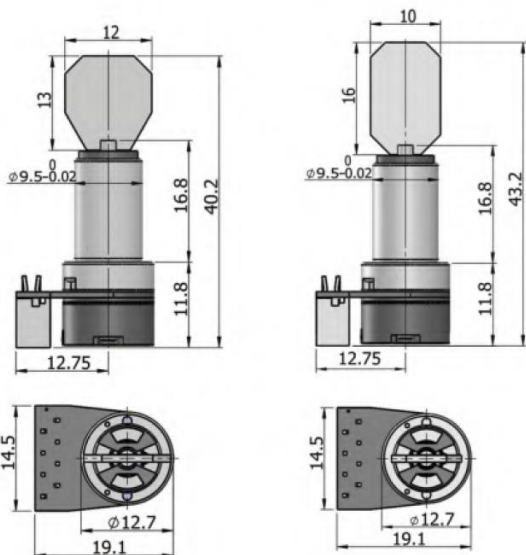

UltraGalvo 7mm

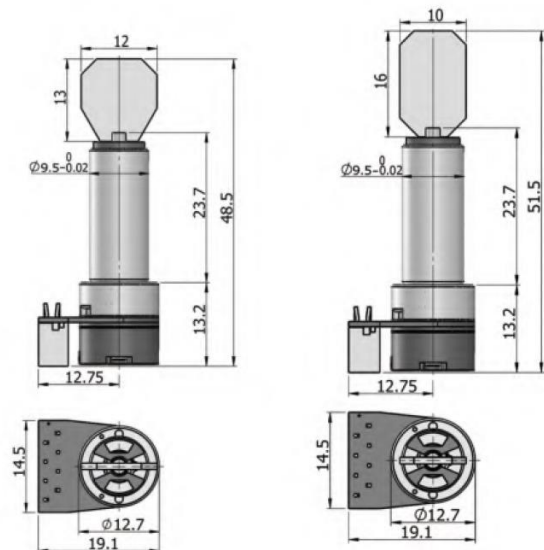

UltraGalvo 8.5mm

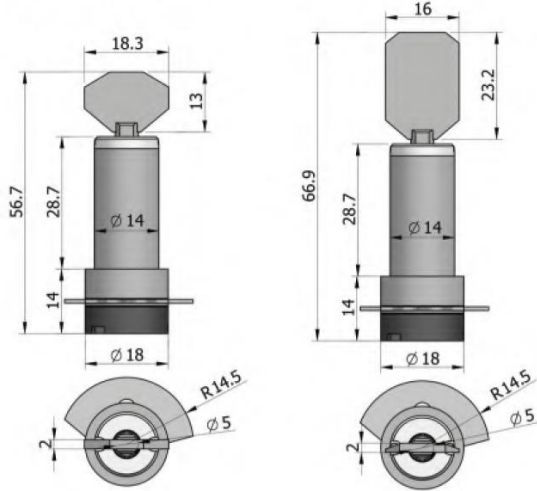

UltraGalvo 10mm

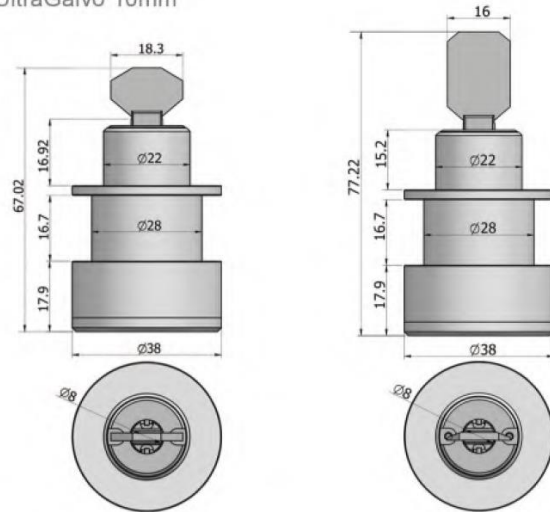

UltraGalvo 14mm

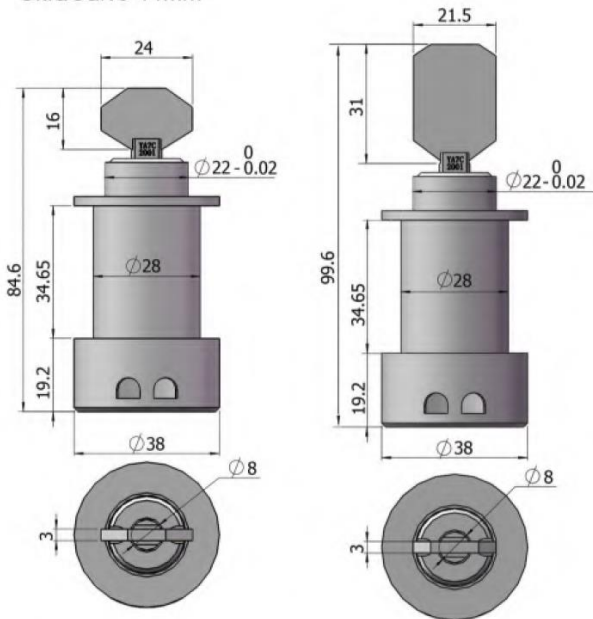

UltraGalvo 20mm

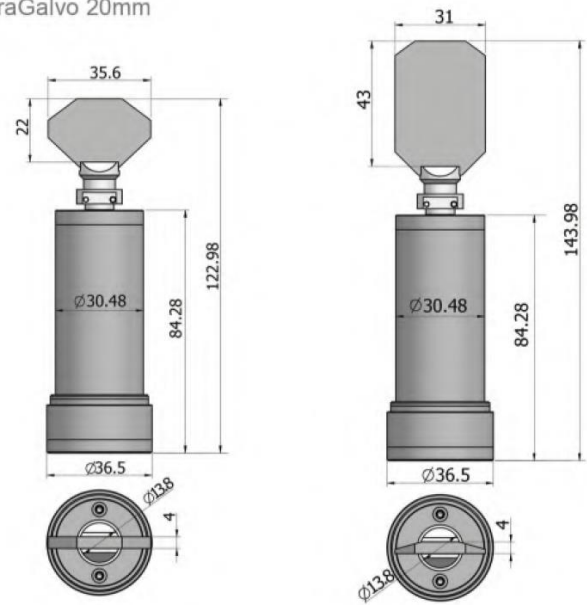

UltraGalvo 30mm

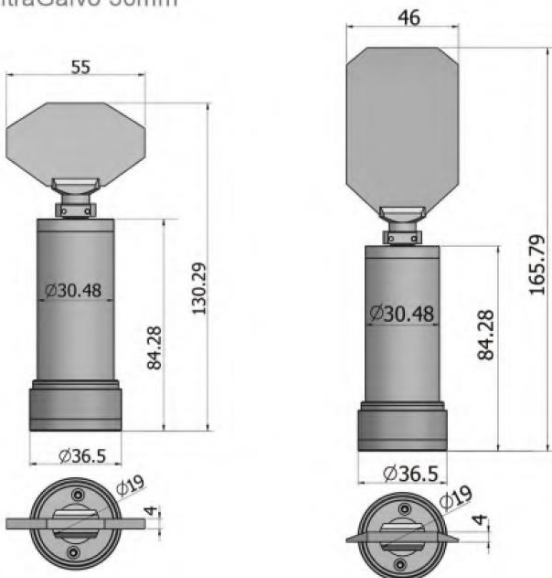

UltraGalvo 50mm

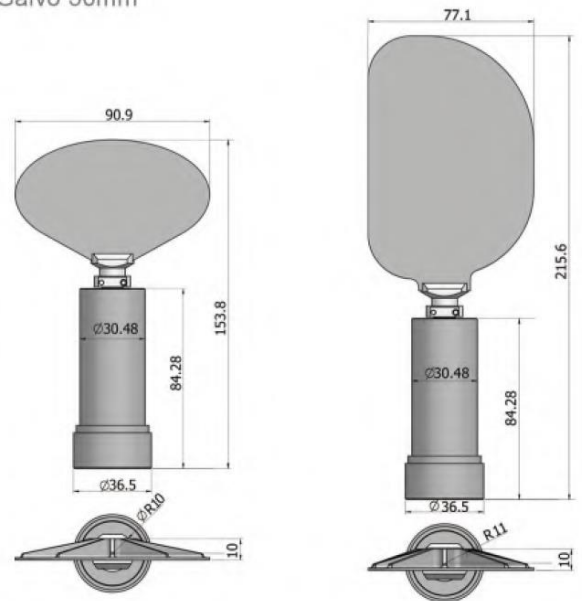

## Extra-Galvo Motor



### Technical Parameters

Extra-Galvo Motor	S	M	L
Input Beam Aperture (mm)	10	14	20-30
Moment of inertia(g · cm <sup>2</sup> )	0.6	1.5	7.2
Force constant(N · mm/A)	7.5	15	24
Coil resistance( $\Omega$ )	2.7	2.6	1.58
Coil inductance( $\mu$ H)	155	275	385
Maximum continuous current(A)	2.5	3.5	5
Peak current(A)	10	10	10
Rise Time(ms)	0.2	0.3	0.7
Weight(g)	220	300	400

### TECHNICAL DRAWING

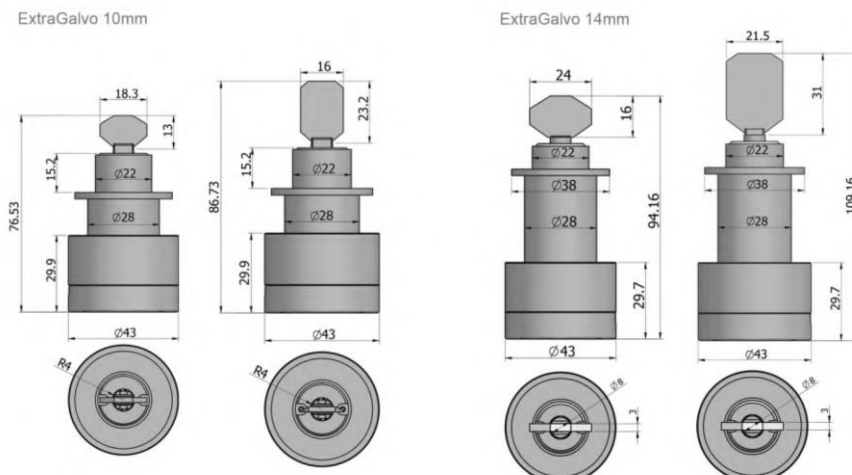

ExtraGalvo 20mm

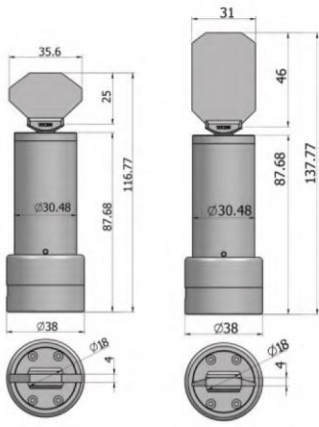

ExtraGalvo 30mm

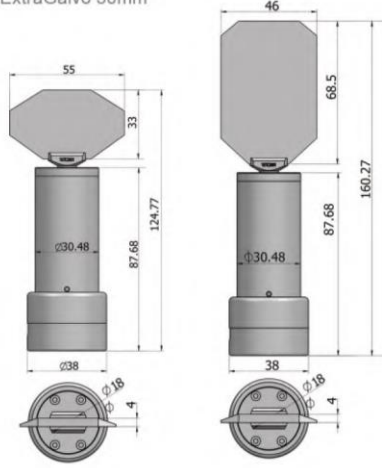

## DRIVER



Digital Driver



Medical Analog Driver



Analog Driver

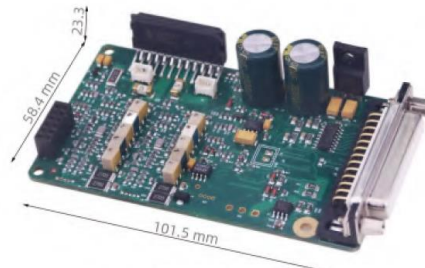

3-in-1 Analog Driver