

Dual Polarized Horn Antenna

1-12GHz

- Low VSWR
- Dual Polarization
- Excellent impedance match and radiation pattern control
- SMA Female Connector

The Atlantic Microwave Antenna shows uniform gain through its frequency span, resulting in excellent performing characteristics and directionality.

Its convenient shape reduces the antenna volume and weight making it specially suitable for mobility requirements during operation.

Made of lightweight corrosion-resistant aluminium, has been designed to provide years of trouble-free indoor operational capabilities, in a fixed location, ideally suited for EMI testing, system integration, CATR, direction finding, surveillance and antenna gain and pattern measurements.

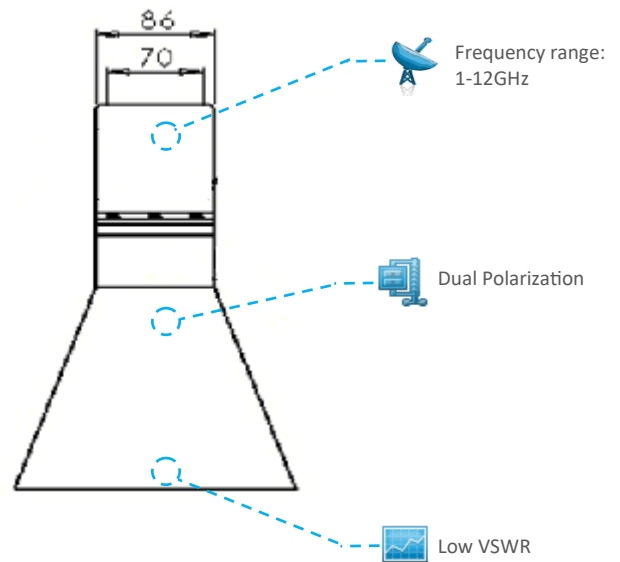

RF Parameters

Frequency Range	1-12GHz		
Gain	7 - 18 dB		
Polarization	Dual		
Power Handling	20W max.		
3dB Beamwidth	Min	25°	
	Max	75°	
VSWR	Typ.	2.0	
Input Type	Coaxial	Impedance (Ω)	50
Operation Temperature	-55°C ~ +75°C	Size	210mm×210mm×230mm (excluded mounting plate)
Storage Temperature	-65°C ~ +85°C	Material	Aluminium
Input Connector	SMA Female	Location	Indoor
Isolation on Port	>20 dB		

Note 1: The specification provided is at nominal bias voltage and at 25°C unless otherwise specified.

Note 2: The specification is subject to regular reviews and will be updated from time to time as part of our continuing product development and improved spec accuracy.

Note 3: Operation beyond the quoted limits stated above may cause instantaneous and permanent damage.

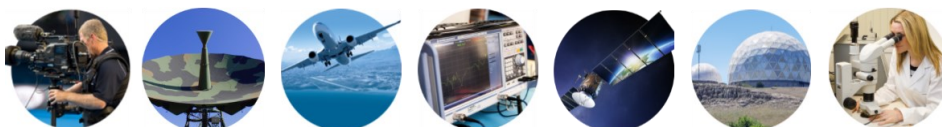

Outline Drawing:
All dimensions are in mm

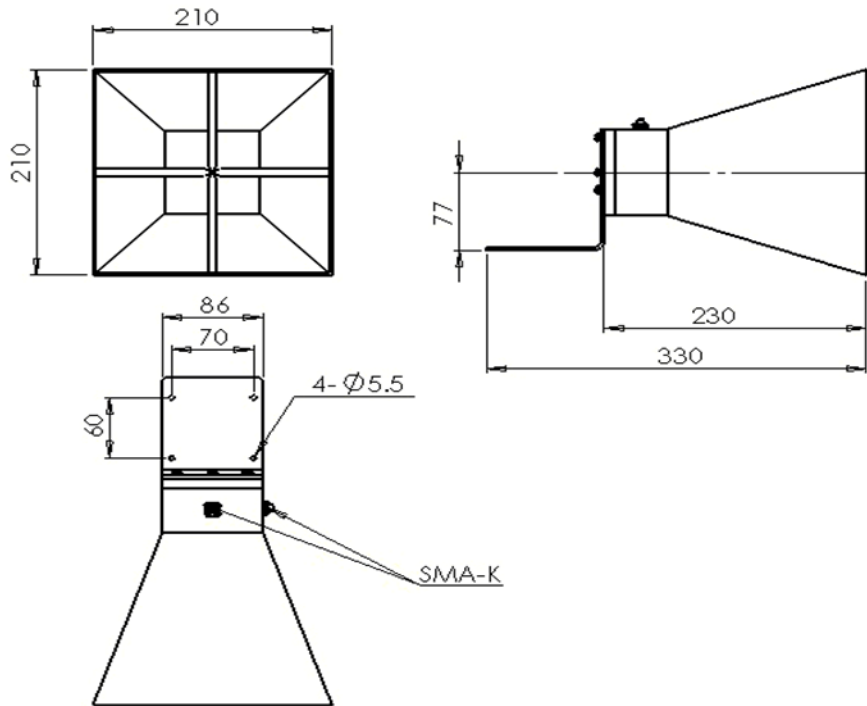

Typical RF Performance

Gain

Frequency (GHz)	Max Gain (dB)
1	7.4
2	10.7
4	12.3
6	16.5
8	16.4
10	14.3
12	17.6

Note 1: The specification provided is at nominal bias voltage and at 25°C unless otherwise specified.

Note 2: The specification is subject to regular reviews and will be updated from time to time as part of our continuing product development and improved spec accuracy.

Note 3: Operation beyond the quoted limits stated above may cause instantaneous and permanent damage.

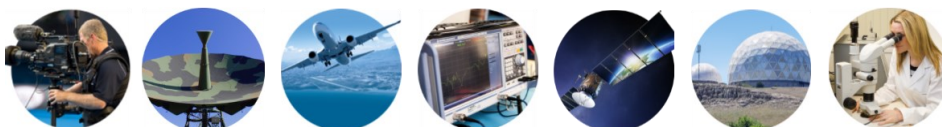

Beamwidth

Frequency (GHz)	E-Plane 3dB Beamwidth	H-Plane 3dB Beamwidth
1	63°	72°
2	35°	51°
4	49°	26°
6	51°	26°
8	41°	35°
10	26°	25°
12	29°	31°

Pattern

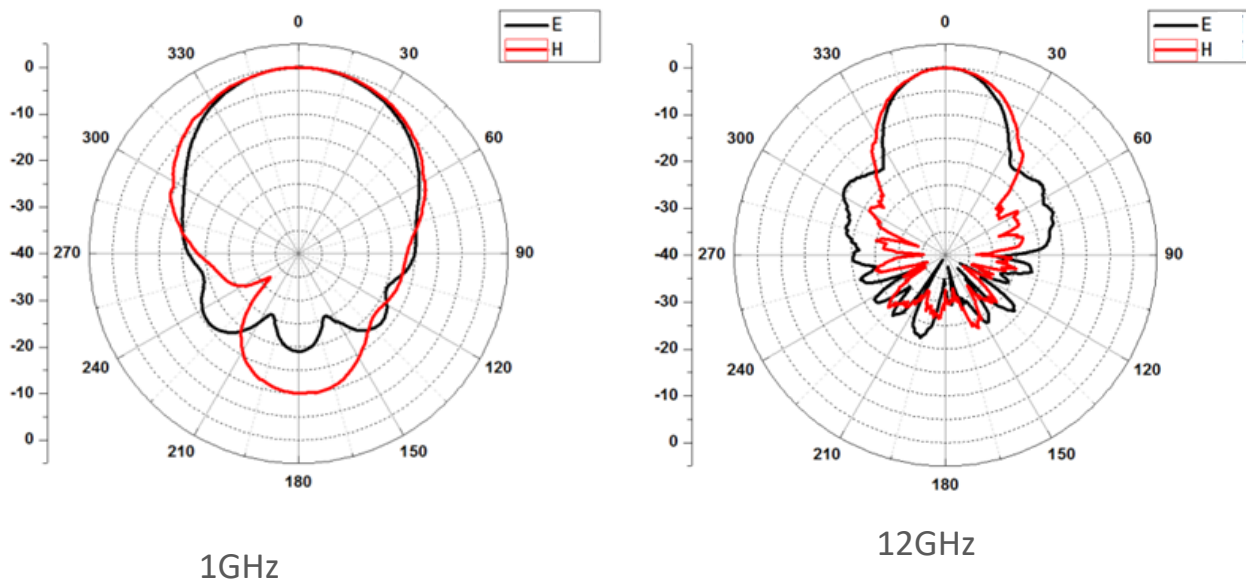

Note 1: The specification provided is at nominal bias voltage and at 25°C unless otherwise specified.

Note 2: The specification is subject to regular reviews and will be updated from time to time as part of our continuing product development and improved spec accuracy.

Note 3: Operation beyond the quoted limits stated above may cause instantaneous and permanent damage.

