

TFLN Thermo-optic modulator DP-IQ Modulator Bias Controller

TFLN-DPIQ-01

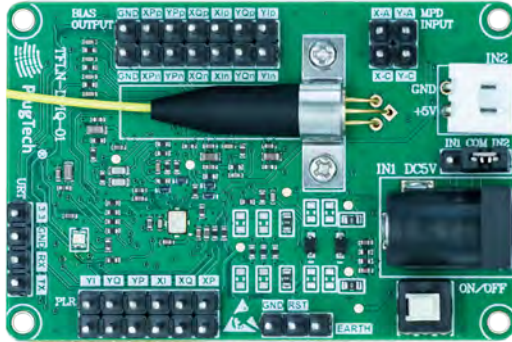

Figure 1. Top View

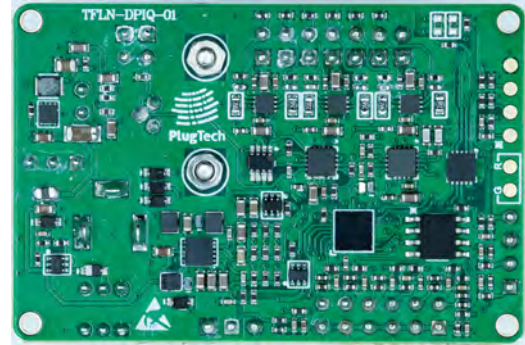

Figure 2. Bottom View

Feature

- Simultaneously provides six automatic bias voltages for Dual Polarization IQ modulators
- Modulation format independent:
QPSK, QAM, OFDM, SSB verified
- I, Q arms: controll on Null modes
High extinction ratio: 50dB max¹
- P arm: controll on Q+ and Q- modes
Accuracy: $\pm 2^\circ$
- Low profile: 54mm(W) \times 37mm(D) \times 14mm(H)
- High stability: fully digital implementation
- Easy to use:
5V DC power supply
Manual operation with mini jumper
Flexible OEM operations through UART
- Two different modes to provide bias voltages:
a. Automatic Bias Control
b. User defined bias voltage
- Flexible working point selection:
a. Controller automatically searches locking point
b. User defined locking point

Application

- TFLN and other DP-IQ modulators with bias heaters
- QPSK, QAM, OFDM, SSB and etc
- Coherent Transmission

Ordering Information

Part No.: TFLN-DPIQ-01

Contact: info@plugtechmbc.com

Telephone: +86 13790119725, +852 66459366

Introduction

A DP-IQ modulator consists of two IQ modulators and a polarization rotator. Each DP-IQ modulator consists of six different modulators: YI,YQ,XI, XQ arms are intensity modulators, YP,XP arms are phase modulators. Plugtech's modulator bias controller is specially designed for DP-IQ modulators to ensure a stable operation state in various operating environments. Based on its fully digitized signal processing method, the controller can provide ultra stable performance.

The controller injects a low frequency, low amplitude dither signal together with a bias voltage into the modulator. It keeps reading the output from the modulator and determines the condition of the bias voltage and the related error. A compensate bias voltage will be applied afterwards according to the previous measurements. In this way, the DP-IQ modulator is ensured to work under a proper bias voltage.

Ordering Guide

Model	Output range
TFLN-DPIQ-01A-040	0-4V
TFLN-DPIQ-01A-080	0-8V
TFLN-DPIQ-01A-100	0-10V
TFLN-DPIQ-01S-***	Custom range

The maximum output voltage of the controller (V_{max}) should not exceed the maximum input voltage of all the modulator heaters and satisfy the following condition: $(V_{max})^2 > P_\pi \times R_{Heater} \times 0.002$, where P_π is modulator's thermo-optic bias heater P_π value (unit:mW) and R_{Heater} is resistance value (unit:ohm) of modulator's heater.

¹ The highest extinction ratio depends on and cannot exceed the system modulator maximum extinction ratio.

Performance

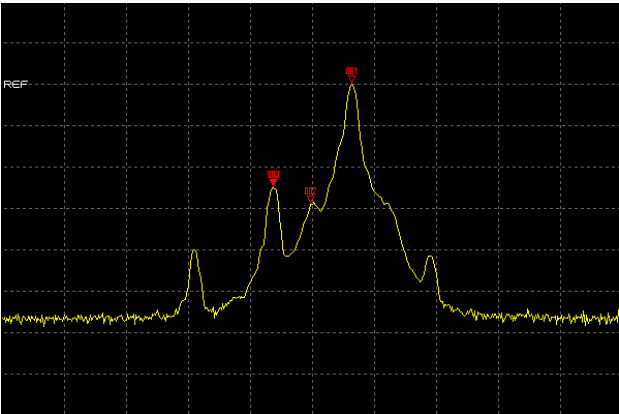

Figure 3. SSB Spectrum

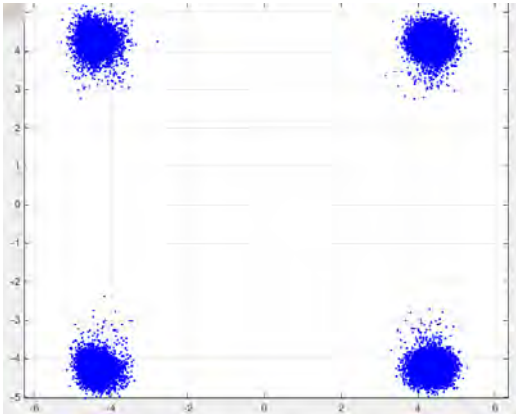

Figure 4. QPSK Constellation

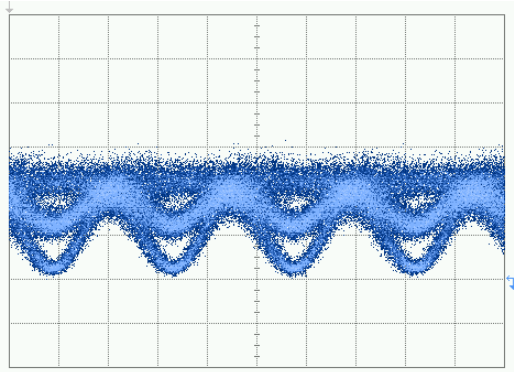

Figure 5. QPSK-Eye pattern

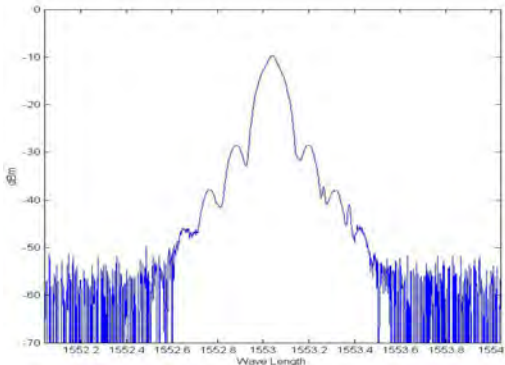

Figure 6. QPSK Spectrum

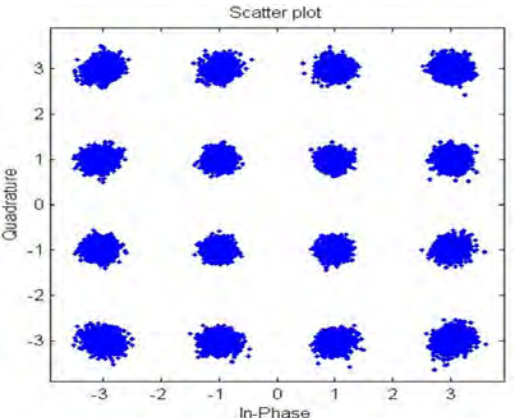

Figure 7. 16-QAM Constellation pattern

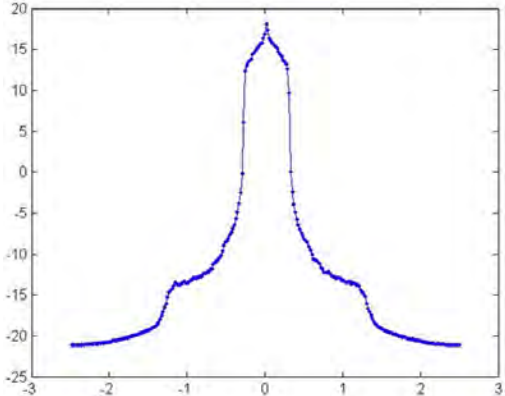

Figure 8. 16-QAM Spectrum

TFLN-DPIQ-01

Specifications

Parameter	Min	Typ	Max	Unit	Note
Control Performance					
I, Q arms are controlled on Null(Minimum) point					
Extinction ratio		MER ¹	50	dB	
P arm is controlled on Q+(right quadrature) or Q-(left quadrature) point					
Accuracy at Quad	-2		+2	degree	
Stablization time		50		s	
Electrical					
Positive power voltage	+4.5	+5	+5.5	V	
No-load current ²	60		120	mA	
Operating current	70		700	mA	
Output voltage range	0		4	V	TFLN-DPIQ-01A-040
	0		8	V	TFLN-DPIQ-01A-080
	0		10	V	TFLN-DPIQ-01A-100
Dither amplitude		1% P_{π}		mW	
Feedback input current ^{3,5}	0.001		0.316	mA	
Optical					
Input optical power ^{4,5}	-30		-5	dBm	
Input wavelength	1100		1650	nm	

¹ MER refers to intrinsic Modulator Extinction Ratio. The extinction ratio achieved is typically the extinction ratio of the modulator specified in modulator datasheet.

² The working current when the output port of the controller is not connected to the modulator.

³ Use modulator's built-in PD as feedback input.

⁴ Use controller's onboard PD as feedback input.

⁵ Please be noted that the input optical power does not correspond to the optical power at the selected bias point. It refers to the maximum optical power that the modulator can export to the controller within the output range of controller.

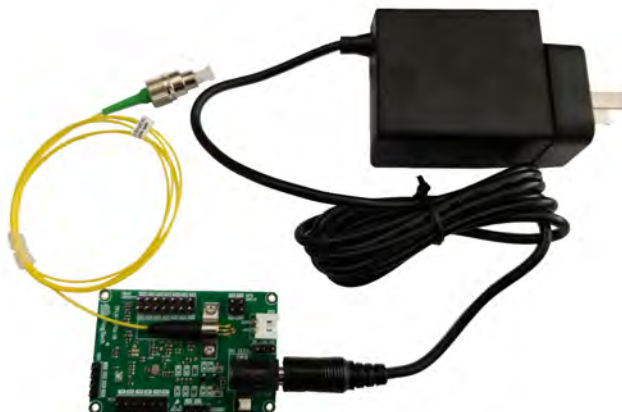

Figure 9. Controller with adaptor

TFLN-DPIQ-01

User Interface

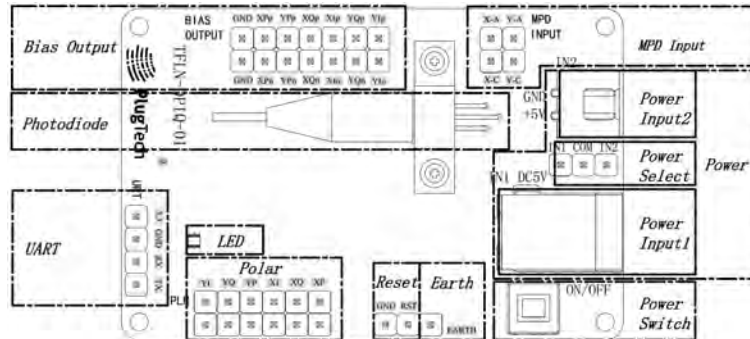

Figure 10. Assembly

Group	Operation	Explanation
Photodiode ¹	Connect with optical coupler at modulator's output	Use controller's onboard PD as feedback input
MPD Input ¹	Y-C, X-C: Connect modulator built-in PD's Cathode	Use modulator's MPD as feedback input
	Y-A, X-A: Connect modulator built-in PD's Anode	Y for Y-polarization, X for X-polarization
Power	Power Input1: Connect +5V DC adaptor	Use +5V DC power adaptor as power supply
	Power Select: switch power input channel	e.g. connect IN1 and COM to active Power Input 1
	Power Input2: Connect +5V DC supply	Use other +5V DC source as power supply
Power Switch	Turn on/off bias controller	Press the switch to turn on/off the controller
Earth	Ground pin of bias controller	
Reset	Insert jumper and pull out after 1 second	Reset the controller
Polar ²	PLR-YI: No jumper(Positive); with jumper(Negative)	Positive: Null mode; Negative:Peak mode
	PLR-YQ: No jumper(Positive); with jumper(Negative)	Positive: Null mode; Negative:Peak mode
	PLR-YP: No jumper(Positive); with jumper(Negative)	Positive: Q+ mode; Negative: Q- mode
	PLR-XI: No jumper(Positive); with jumper(Negative)	Positive: Null mode; Negative:Peak mode
	PLR-XQ: No jumper(Positive); with jumper(Negative)	Positive: Null mode; Negative:Peak mode
	PLR-XP: No jumper(Positive); with jumper(Negative)	Positive: Q+ mode; Negative: Q- mode
UART	Operate controller via UART	3.3: 3.3V reference voltage
		GND: Ground
		RX: Receive of controller
		TX: Transmit of controller
LED	Green light constantly on	Working under tracking state
	Green light blinking every 0.2s	Processing data and searching for controlling point
	Green light blinking every 1s	Feedback input is too weak
	Red light blinking every 3s	Feedback input is too strong
	Red light constantly on	Working under PauseControl mode or Manual mode
Bias Voltages	YIp, YIn: Bias voltage for Y-polarization I arm	YIp: Positive side; YIn: Negative side or ground
	YQp, YQn: Bias voltage for Y-polarization Q arm	YQp: Positive side; YQn: Negative side or ground
	YPp, YPn: Bias voltage for Y-polarization P arm	YPp: Positive side; YPn: Negative side or ground
	XIp, XIn: Bias voltage for X-polarization I arm	XIp: Positive side; XIn: Negative side or ground
	XQp, XQn: Bias voltage for X-polarization Q arm	XQp: Positive side; XQn: Negative side or ground
	XPp, XPn: Bias voltage for X-polarization P arm	XPp: Positive side; XPn: Negative side or ground
	GND: Controller's extra GND pins	Ground

¹ Only one choice shall be chosen between using controller photodiode or using modulator photodiode. It is recommended to use controller photodiode for Lab experiments for two reasons. Firstly, controller photodiode has ensured qualities. Secondly, it is easier to adjust the input light intensity. If using modulator's internal photodiode, please make sure that the output current of photodiode is strictly proportional to input power.

² Polar depends on system RF signal. When there is no RF signal in the system, the polar should be positive. When RF signal has amplitude greater than a certain level, the polar will change from positive into negative. At this time, Null point and Peak point will switch with each other. Q+ point and Q- point will switch with each other as well. Polar switch enables user to change the polar directly without changing operation points.

UART Command List

UART of the controller works at TTL(3.3V) level with following parameters: 57600 baud rate, 8 data bits, no parity bit, 1 stop bit.

Note: For detailed instructions on using UART Command, please refer to Operation Guide file.

Description	Command ID ¹	Data Send ¹	Data Received ²	Unit
Get optical power ³	0x65	NA	Current optical power ⁴	μ W
Get bias voltage	0x66	Arm ⁵	Current bias voltage ⁴	V
Get P_{π}	0x7C	Arm ⁵	Modulator P_{π} ⁴	mW
Get polar	0x68	NA	Current polar of controller ⁶	
Set control mode	0x6A	Control mode ⁷	Status ⁸	
Set output voltage ¹¹	0x6B	Arm ⁵ + Voltage ¹²	Status ⁸	
Set polar	0x6C	Polar ¹³	Status ⁸	
System reset ¹⁴	0x6D	NA	NA	
Set heater resistance ¹⁵	0x79	Arm ⁵ + Resistance ¹⁶	Status ⁸	
Set tracking position ¹⁷	0x77	Target position ¹⁸	Status ⁸	
Set dither amplitude ¹⁹	0x6F	Dither amplitude ²⁰	Status ¹⁰	
Pause control ²¹	0x73	NA	Status ¹⁰	
Resume control ²²	0x74	NA	Status ¹⁰	

¹ Bias controller can be controlled by a master device, such as a microprocessor, through UART. Command ID and Data Send refer to the data sent by master device. Each command should be sent in a frame of 7 bytes following the sequence of Command ID(1 byte) + Data(6 bytes). For data bytes, it should be filled from the first byte and unused data bytes should be zero.

² Data received refer to the data received by master device. For data received, it has a frame of 9 bytes following the sequence of Command ID(1 byte)+Data(8 bytes). Similar to data send, received data bytes will be filled from the first byte and unused data bytes will be filled with zero.

³ The average power corresponds to the optical power which inputs into the controller.

⁴ Data received is 4 byte floating point number(Little Endian).

⁵ Arm of the DP-IQ modulator. (0x01: Arm YI; 0x02: Arm YQ; 0x03: Arm YP; 0x04: Arm XI; 0x05: Arm XQ; 0x06: Arm XP)

⁶ Six bytes will be received. Each byte represents polar of one arm. Byte one is polar of arm Y-I, byte two is polar of arm Y-Q and byte three is polar of arm Y-P. Byte four, five and six are the polar for X-I, X-Q and X-P respectively.

⁷ Control mode is one byte. (0x01: Auto Control; 0x02: Manual Control)

⁸ One byte. (0x11: Success; 0x88: Error)

¹¹ Set output voltage function can only be used when bias controller is working under manual mode.

¹² Three bytes. For example, if 3.215V is required for output, the voltage should be multiplied by 1000 to convert the value to integer, i.e. 3215. Then convert 3215 to hex format. Hex format of 3215 is 0x0C8F. Byte one is the upper half of the final hex result, i.e. 0x0C. Byte two is the lower half, i.e. 0x8F. Byte three is sign of the voltage, 0x00 for positive, 0x01 for negative.

¹³ Six bytes. These bytes are used to represent polar of arm Y-I, Y-Q, Y-P and X-I, X-Q, X-P. (0x01: Positive; 0x02: Negative)

¹⁴ Reset the controller. It will start from initialization.

¹⁵ Heater resistance should be calculate when the controller is connected to a different modulator.

¹⁶ Two bytes. The value of the first byte is the first half (0xAB of the heater resistance value converted to hexadecimal (e.g. 0xABCD), and the value of the second byte is the second half (0xCD) of the heater resistance (hexadecimal).

¹⁷ Preset target tracking point. For example, when the position value is set to 2 in Null point mode, the controller will try to lock the 2nd Null point. When user set a new value to the controller, it will be stored in Flash memory and automatically loaded when the controller is turned on or reset.

¹⁸ Six bytes. The first byte is target position for Arm Y-I, the second byte is target position for Arm Y-Q and the third

byte is target position for Arm Y-P. Byte four, five and six are the target positions for X-I, X-Q and X-P respectively.

¹⁹ Set dither amplitude on arm Y-I, Y-Q, X-I and X-Q. It can only be the multiple of $1\%P_{\pi}$. For example, if dither amplitude of arm Y-I is set to be 3. Then dither amplitude on arm Y-I will be 3%. The amplitude's factory default value is 1, when user set a new value to the controller, it will be stored in Flash memory and automatically loaded when the controller is turned on or reset.

²⁰ Four bytes. Format of the data is $(\text{dither amplitude YI} \times 10) + (\text{dither amplitude YQ} \times 10) + (\text{dither amplitude XI} \times 10) + (\text{dither amplitude XQ} \times 10)$. One byte for each arm. For example, when user expect to set the parameter to 3, the data send to controller should be 30.

²¹ This function will pause the controller's automatic control. Dither will be stopped and bias voltage output of arm YI, YQ, YP, XI, XQ and XP will remain at the value when the pause command is executed.

²² This function is used together with Pause Control. When pause control is executed and the automatic control is needed, executing this command will resume automatic control.

TFLN-DPIQ-01

Environmental Characteristics

Parameter	Min	Typ	Max	Unit
Operating temperature	-20		80	°C
Storage temperature	-20		80	°C

Dimension

Parameter	Value
Dimensions (W× D× H)	54mm× 37mm × 14mm
Weight	100g

Typical Application

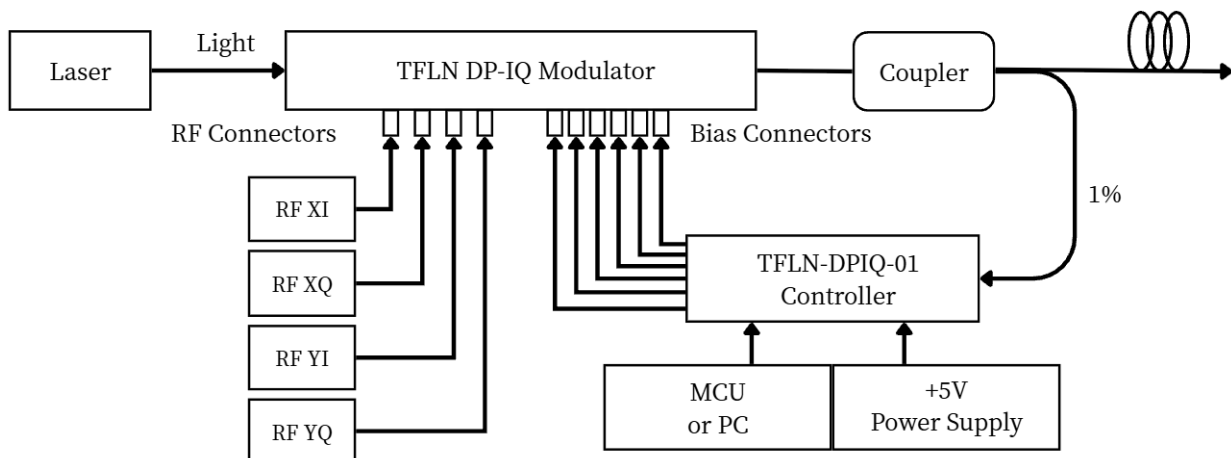

The controller is easy to use.

Step1. Connect 1% port of the coupler to the photodiode of the controller.

Step2. Connect bias voltage output of the controller(through SMA or 2.54mm 2-pin header) with bias port of the modulators (Y-I, Y-Q, YP, X-I, X-Q,X-P and GND).

Step3. Provide controller with +5V DC voltage.

Step4. Turn on the controller and it will start to work.

NOTE 1. Please be ensured that RF signal of the whole system is on before turn on/resetting the controller.

NOTE 2. Please calibrate the modulator heater resistance value via GUI or UART command while the controller is deployed to a different modulator.

NOTE 3. If the controller indicates the input light is too weak or too strong, the input light intensity shall be adjusted. After adjustment, controller shall be restarted to ensure proper operation.



This is an electrostatic-sensitive device. Please observe precautions for handling

**Content of the datasheet is subject to modification.
Please send an enquiry email to info@plugtechmbc.com for latest version of datasheet.**

Revision History

Version	Content	Date
1.0.0	First Release	2026-Feb