

V5051

Quad-Port PCI Express FPGA Card

Benefits

High-density FPGA PCIe Card for next generation data distribution, processing, and networking systems

Supports 1/10/25/40/100G Ethernet, 1/2/4/8/16/32G Fibre Channel, 1/2/2.5/10G sFPDP, ARINC 818-2

Out-of-the-box ultra-low latency and high-bandwidth performance

Programmable FPGA with a powerful development framework

Next-generation host interface connection bandwidths

Wide range of FPGA sizes and memory configuration options

Features

Four SFP28 ports accommodate:

- 4x 25G Ethernet
- 1x 40/100G Ethernet
- 4x 10G Ethernet
- 4x 1G Ethernet
- 4x 1/2/4/8/16/32G Fibre Channel
- 4x 1/2/2.5/10G sFPDP
- 4x ARINC 818-2

Xilinx Virtex UltraScale+ FPGA (VU9P)

Supports PCIe Gen3 x 16 and Gen4 x 8

PPS time synchronization with nSec resolution

Thermal sensors for monitoring card temperature

Robust FPGA development framework

Advanced APIs that support multi-core and multi-processor architectures

Optimized Linux drivers and libraries

Overview

The V5051 is the next generation of New Wave DV's flagship programmable network products and the industry's highest performance FPGA network card in production today. It is powered by the latest Xilinx Virtex UltraScale+ FPGA technology. Purpose-built for processing network data in real-time, the V5051 has been optimized to provide the lowest possible latency and the highest possible performance. This makes it ideal for executing sophisticated algorithms, processing streaming data, and running a wide range of functions as close as possible to the network.

To meet priority deadlines for rolling out new products, the Development Framework provides the standard toolset and debug capabilities required to create applications on the V5051 PCI Express FPGA card quickly.



V5051

Quad-Port PCI Express FPGA Card

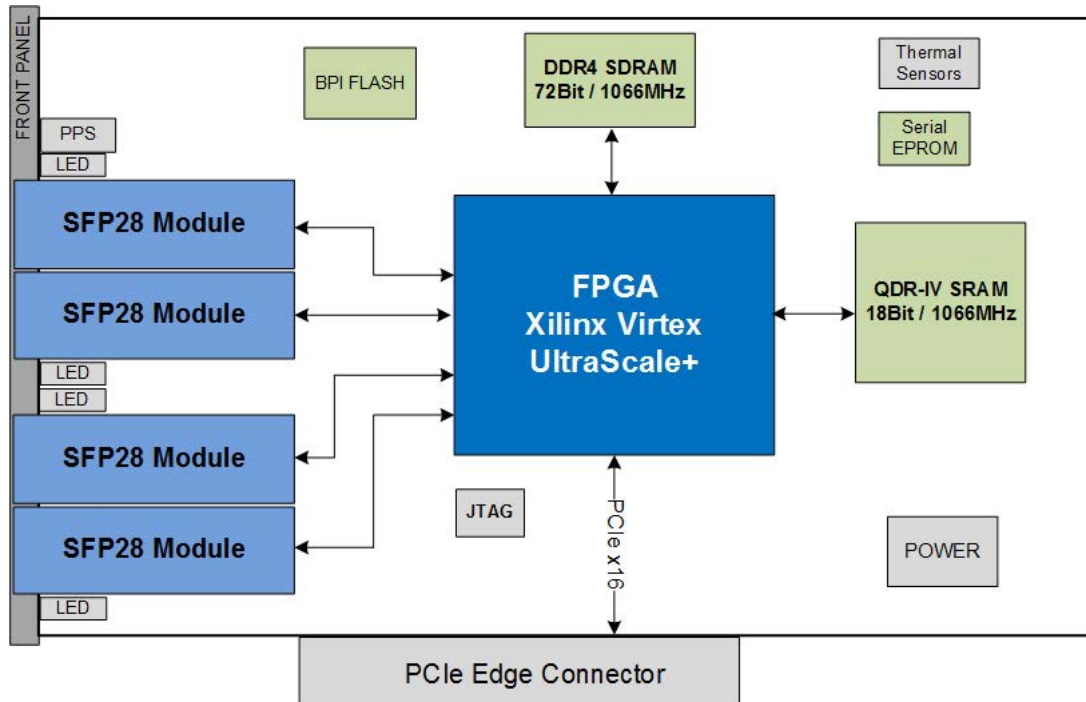

> V5051 Block Diagram

Simplified Programmability Framework

The V5051 can optionally ship with a Development Framework, a fully-integrated and flexible toolset that provides the infrastructure necessary to ensure rapid deployment of custom applications. The framework abstracts the details of the protocol and interfaces, memory controllers and host fabric interfaces, thereby reducing the development effort and schedule for designers to implement custom solutions.

Multi-processor Multi-core Support

The V5051 is uniquely suited to system architectures involving multiple processing cards on a common switched data plane. Specifically, the V5051 supports shared access from multiple host processors, enabling it to function as a cost-effective, high-performance gateway. This feature enables a single high-speed pipe to carry multiple virtual channels in systems that need to spread or load balance sensor data across processor farms.

Optional Protocol Engines

The V5051 is an extremely flexible FPGA-based interface card. The card features all of the necessary hardware, FPGA IP cores, plus software drivers to support Ethernet, Fibre Channel, sFPDP, and ARINC 818. New Wave also offers options for custom high-speed serial protocols or user-developed IP cores.

Operation Customization

The V5051 is an FPGA-based network card that can be customized to fit your requirements. New Wave provides access to the FPGA for customers to customize, however New Wave can also modify existing cores or develop new cores for your applications. If you have specific networking requirements, New Wave can help you accomplish your goals.

V5051

Quad-Port PCI Express FPGA Card

Complete Product Support Program

New Wave DV prides itself on its excellent customer support, a fact that is echoed by our customers. New Wave DV provides industry standard warranty on its products, but it is the human factor that makes our support so valuable to our customers. Our team takes the time and effort to ensure that the customer experience with our products is a positive one.

Our Commitment

New Wave DV is committed to providing the latest innovations in technology, architectures, and techniques to keep our customers one step ahead of the rest. Our products, complete with the Development Framework, are intended to offer our customers an entirely unique out-of-the-box experience.

Technical Specifications

NETWORK INTERFACE

Four SFP28 optical ports

ETHERNET PROTOCOL

TCP, UDP, ARP, ICMP, Multicast, Broadcast

FIBRE CHANNEL PROTOCOLS

RDMA, AV, ASM

ADDITIONAL PROTOCOLS

sFDP, ARINC 818-2

FPGA DEVICE

Xilinx Virtex UltraScale+ (VU9P)

Xilinx Kintex UltraScale (KU115)

MEMORY

One bank of 4GB to 16GB 72-bit up to 1066MHz DDR4 SDRAM

One bank of 36Mbit to 144Mbit 18-bit 1066MHz QDR-IV SRAM

FLASH

One 32MB memory for storing a default configuration image

HOST INTERFACE

PCI Express Gen4 x8

PCI Express Gen3 x16

EXTERNAL INTERFACE

32 differential pairs (user configurable)

PPS Interface for time synchronization with μ second resolution

RS-232 serial interface for debug

THERMAL SENSORS

2 digital temperature sensors

COMPLIANCE

PCI Express Card Electromechanical Specification, Rev 2.0

IEEE 802.3ae 2002

IEEE 802.3ba 2010

FC-FS-3 INCITS 470-2011

FCC 47 CFR Part 15, Subpart B, Class A (USA)

IEC 60950-1 (International)

RoHS Directive 2002/95EC

FORM FACTOR

Full-length¹, standard-height PCIe tri-width board

Dual-width option²

234 x 111.15mm (9.22 x 4.38 inches)

POWER REQUIREMENTS

Maximum 55W (preliminary)

TEMPERATURE

Operating: 0 to 45°C

Storage: -40°C to 85°C

¹Minimum length. Designs that exceed backplane-specific PCIe power specifications and require a mating connector to external power will be longer.

²Available on boards for designs that require smaller and/or no additional cooling devices.

V5051 Hardware Part Number Configuration

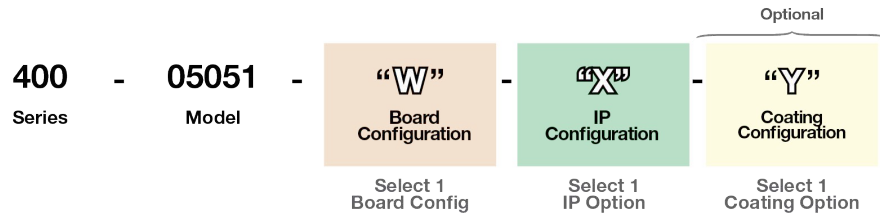

W

Config #	Configuration Option Details			
Select One	FPGA	DDR4	Ports	Rate
20	VU9P	DNP	4	1-25G
50	KU115	DNP	4	1-10G
#70 - #87	Reserved		Reserved	

*P = Populate; DNP = Do Not Populate

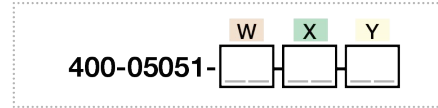

X

Config #	Description
02	Fibre Channel ASM IP Core
17	sFPDP IP Core
21	Fibre Channel ULP IP Core
22	ARINC-818 IP Core
00	No IP

Y

Config #	Description
AR	Acrylic conformal coat
UR	Urethane conformal coat
ER	Epoxy conformal coat
SR	Silicone conformal coat
XY	Parylene conformal coat
BLANK	No conformal coat

FOR MORE INFORMATION

www.newwavedv.com
 info@newwavedv.com
 Phone +1 952-224-9201

New Wave DV
 10260 Viking Drive, Ste 250
 Eden Prairie, MN 55344 USA

