

Quasi-Optical THz Detector Type 3DL 12C LS2500 A1

Product Description

High sensitivity in ultra-wide frequency band and room-temperature operation make ACST Schottky-barrier diode (SBD) based Quasi-Optical detectors the best alternative to available free-space detectors for the low-THz frequency-region.

Bias-free operation allows for system simplicity and ultra-low noise. In contrast to typical THz detectors, the ACST SBD solution is simpler, geometrically smaller, and much faster.

ACST optionally offers also a dedicated power supply unit, which considerably simplify the detector installation and exploitation in customer setups. Detector output is connected to a SMA connector, female.



Fig. 1: Optical view of the product

Application Areas

- THz-imaging systems
- Fast THz screening
- THz spectroscopy

Product Features

- Ultra-Wideband: 50 GHz – 2.5 THz in single device
- Much faster than Golay-Cell detector
- Much higher sensitivity than pyroelectric detector
- Operates at room temperature
- Compact, low power-consumption, simple operation

Tab. 1: Technical Specifications

Technical Specifications	
Lens Type	Silicon; spherical; collimating
Lens Diameter [mm]	12
Antenna Type	Log-spiral
Antenna Bandwidth [GHz]	50 - 2500
Video Amplifier Bandwidth [Hz]	10 Hz - 1 MHz (DC-Coupled)
Responsivity [V/W] (See Fig. 2 below)	22000 @70 GHz; 1100 @1 THz
Output Voltage [V] (recommended max.)	± 3
NEP [pW/Hz ^{1/2}] (See Fig. 2 below)	6
Power Supply Output [V]	± 12
Current Consumption [mA] (max.)	40
Responsivity Measured at [°C]	24

Typical Performance

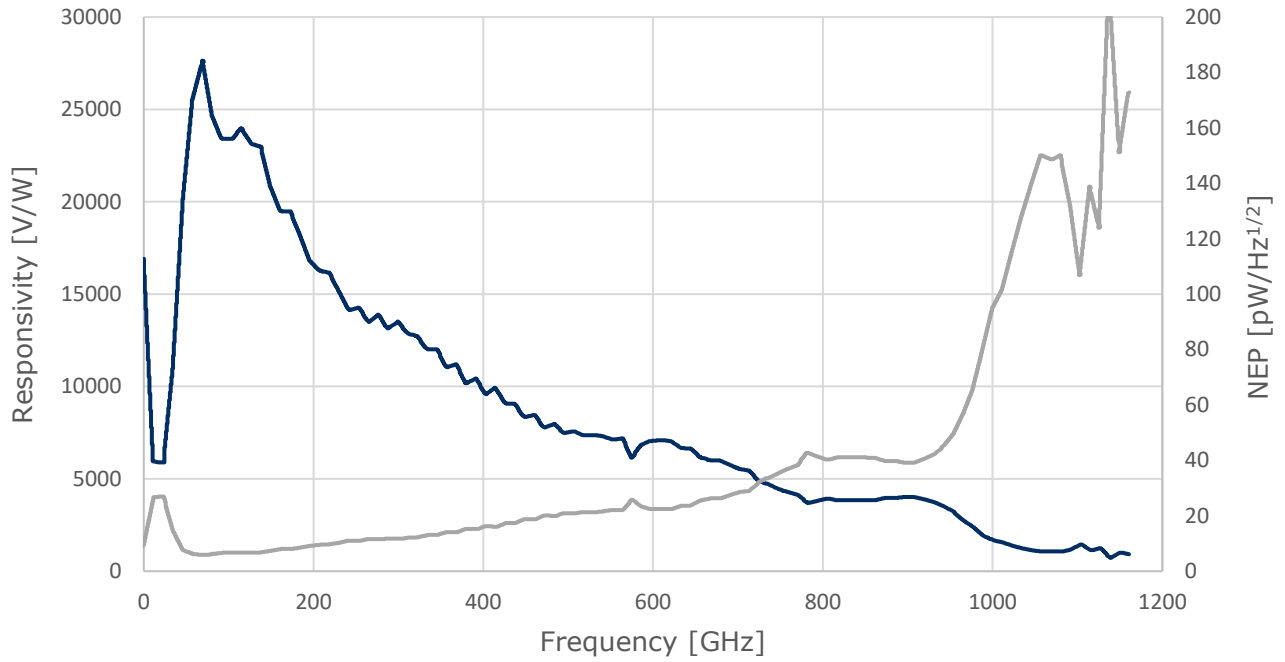

Fig. 2: A1 Responsivity and NEP vs. Frequency

Mechanical Outlines

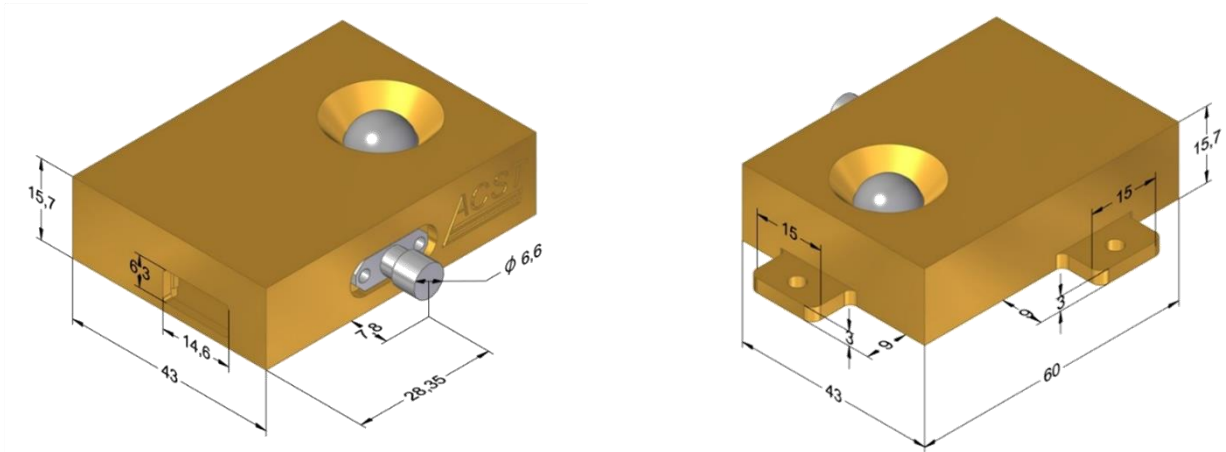
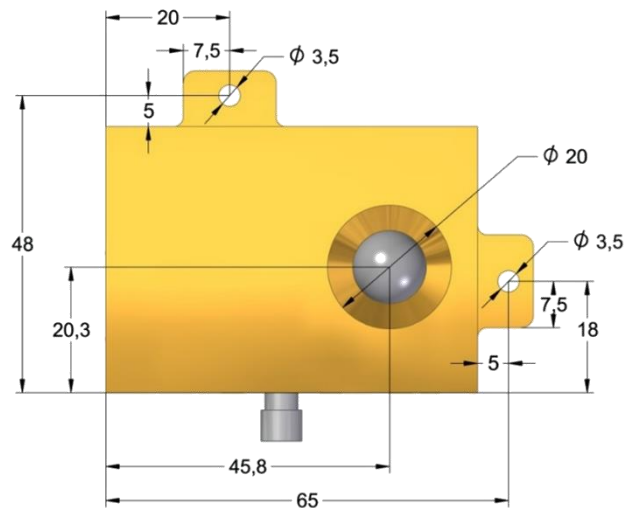

Fig.3: Overall dimensions



Notes

- All plotted data represent typical values. The actual data may vary from unit to unit.
- All tests are carried out at a room temperature of 24 °C.

Caution

- Absolute maximum ratings should not be used under normal operating conditions. Exceeding maximum ratings may lead to permanent failure.
- USB port of the detector should be used only for DC-power as shown in the user Guide. Plugging standard USB connectors may cause damage of Detector and external equipment.

ACST GmbH reserves the right to make changes to the product or information contained herein without notice. Visit www.acst.de for additional data sheets and product information.

