



FLANN MICROWAVE

Calibrated Phase Changers

Series 060 / 061

Features

- 0° – 180° Calibrated Phase Change Range
- Low Insertion Loss

The Flann Series 060 / 061 instruments are fitted with low VSWR dielectric elements coupled to a precision micrometer drive. The micrometer indicates the relative position of the dielectric element in the waveguide. All models provide a minimum of 180 degrees phase change and exhibit a very low insertion loss. The micrometer is fitted with a locking device which enables the adjusting mechanism to be locked at any setting. Two calibrations are provided at standard frequencies within each waveguide band. Alternatively, the two calibration frequencies may be specified by the customer.

In the standard models 06060 to 22060 the dielectric element is introduced into the waveguide in a transverse manner. The standard 060 series instruments do not cover the top 15% of the waveguide frequency band.



Model 20060

When full band coverage is essential special models can be supplied at extra cost and are designated the 061 Series. For example, model 18061 is a full band model covering the frequency range 11.9 GHz to 18.0 GHz. Models 06061 to 22061 have VSWR better than 1.3:1 over the full waveguide band.

Models in the waveguide sizes WG23 (WR22) to WG32 (WR8) introduce the dielectric element into the waveguide via a slot on the centre line of the broad wall and are suitable for the full band operation as standard.

FLANN MICROWAVE LTD.

Dunmere Road
Bodmin
Cornwall
PL31 2QL

GET IN TOUCH:

Tel: +44 (0)1208 77777
sales@flann.com
www.flann.com



FLANN MICROWAVE

Calibrated Phase Changers

Series 060 / 061

Model	Frequency Range (GHz)	Waveguide			VSWR (better than)	Calibration Accuracy	Standard Calibration Frequencies (GHz)	
		WG	R	WR				
06060*	1.14 - 1.73	6	14	650	1.1	2°	1.34	1.53
08060*	1.72 - 2.61	8	22	430	1.1	2°	2.02	2.31
10060*	2.60 - 3.95	10	32	284	1.1	2°	3.05	3.50
11A060*	3.22 - 4.90	11A	40	229	1.1	2°	3.83	4.37
12060*	3.94 - 5.99	12	48	187	1.1	2°	4.62	5.31
13060*	4.64 - 7.05	13	58	159	1.1	2°	5.44	6.25
14060*	5.38 - 8.18	14	70	13	1.1	2°	6.31	7.25
15060*	6.58 - 10.0	15	84	112	1.1	2°	7.72	8.86
16060*	8.20 - 12.5	16	100	90	1.1	2°	9.63	11.07
17060*	9.84 - 15.0	17	120	75	1.1	2°	11.56	13.28
18060*	11.9 - 18.0	18	140	62	1.1	2°	13.93	15.97
19060*	14.5 - 22.0	19	180	51	1.1	2°	17.00	19.50
20060*	17.6 - 26.7	20	220	42	1.15	2°	20.63	23.67
21060*	21.7 - 33.0	21	260	34	1.15	3°	25.46	29.23
22060*	26.4 - 40.1	22	320	28	1.15	3°	30.97	35.53
23061	33.0 - 50.1	23	400	22	1.15	3°	38.70	44.40
24061	39.3 - 59.7	24	500	19	1.15	3°	46.10	52.90
25061	49.9 - 75.8	25	620	15	1.25	3°	58.53	67.17
26061	60.5 - 92.0	26	740	12	1.25	3°	71.00	81.50
27061	73.8 - 112	27	900	10	1.25	3°	85.87	97.93
28061	92.3 - 140	28	1200	8	1.25	3°	108.20	124.1
29061	114 - 173	29	1400	6				
30061	145 - 220	30	1800	5				
31061	172 - 261	31	2200	4				
32061	217 - 330	32	2600	3				

Specifications available on request

Model	Dimensions (mm)			
	A	B Max	C	D
06060	1250	372	216	400
08060	850	242	157	151
10060	480	223	138	151
11A060	450	217	132	151

Model	Dimensions (mm)			
	A	B Max	C	Dia D
12060	370	145	92	86
13060	340	141	89	86
14060	310	138	86	64
15060	240	132	83	64
16060	180	127	79	64
17060	180	125	78	64
18060	150	100	54	35
19060	125	97	52	35
20060	80	95	51	35
22060	70	100	49	12

FLANN MICROWAVE LTD.

Dunmere Road
Bodmin
Cornwall
PL31 2QL

GET IN TOUCH:

Tel: +44 (0)1208 77777
sales@flann.com
www.flann.com



Model	Dimensions (mm)		
	A	B Max	C
23061	75	96	30
24061	75	96	30
25061	60	96	30
26061	60	96	30
27061	60	96	30
28061	60	96	30
29061	Dimensions available on request		
30061			
31061			
32061			

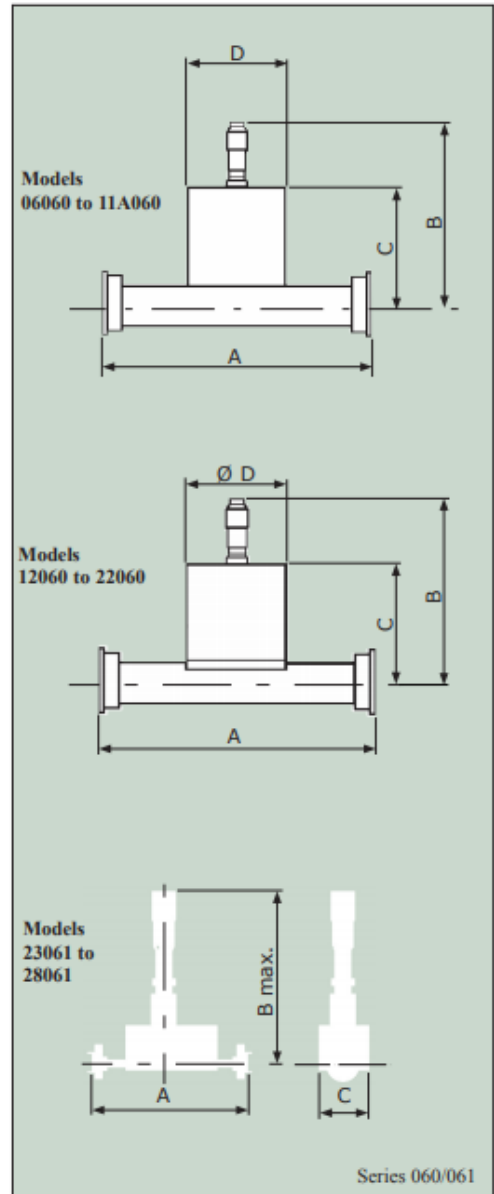

ORDERING INFORMATION

Model: Description

Example: Model 13060 Calibrated Phase Changer

The Full waveguide band model would be 13061

Custom Design

Custom built instruments can be supplied; please contact the sales team for more information

sales@flann.com